



# OtN Helical-Bevel Right Angle Gearmotors and Speed Reducers

OtN Series

## Industries

- Food and Beverage
- Warehousing
- Parcel and Package Sortation
- Oil
- Recycling
- Airport
- Waste Treatment

## Applications

- Unit Handling Conveyors
- Mixers and Agitators
- Turntables
- Chain Conveyors
- Screw Conveyors
- Baggage Handling Conveyor
- Sludge Collection Tanks

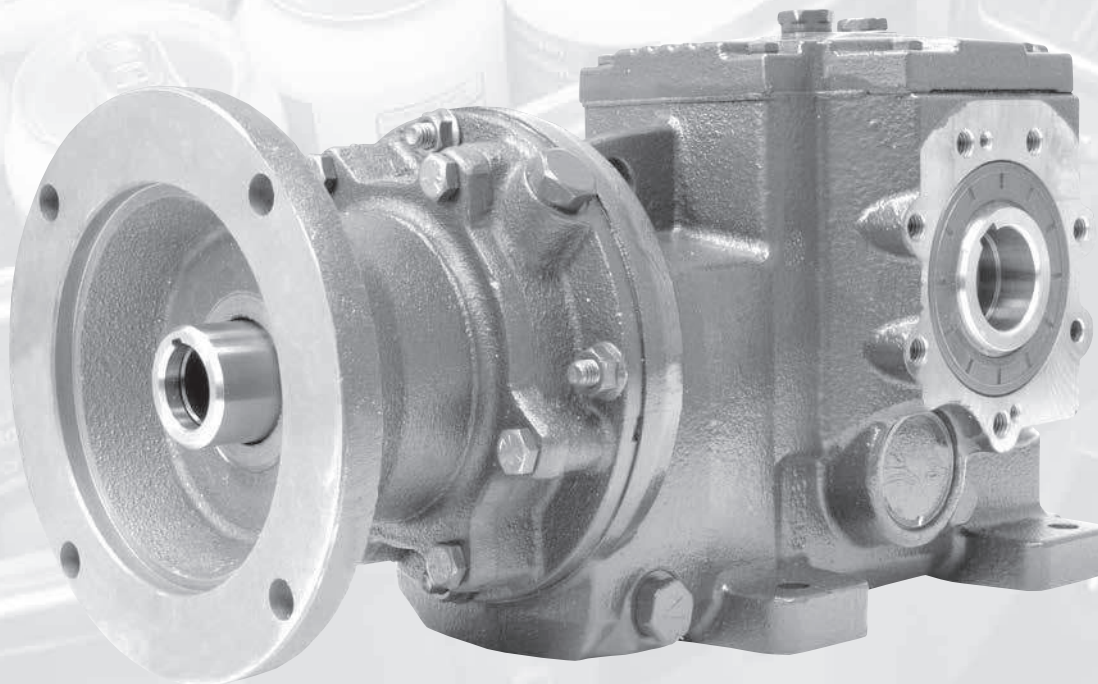
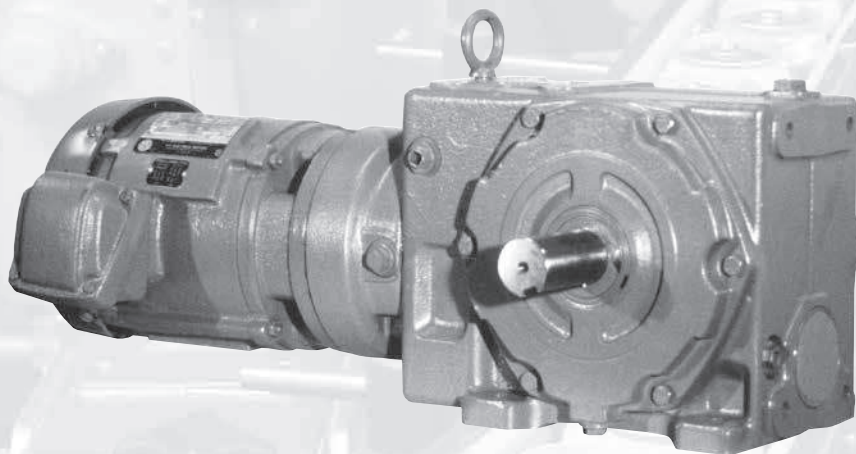

**Browning**<sup>®</sup>

# OtN Helical-Bevel Right Angle Gearmotors and Speed Reducers

OtN Series

**Gearmotor**

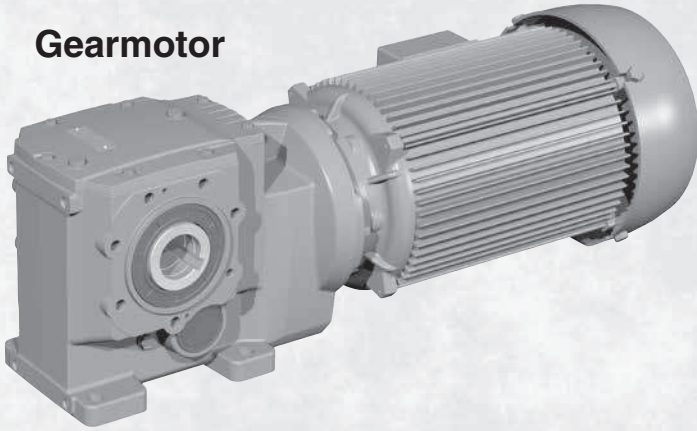

**C-Face**

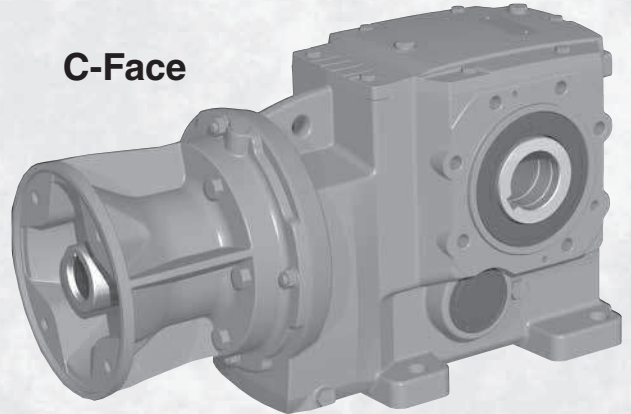

**Input Shaft**

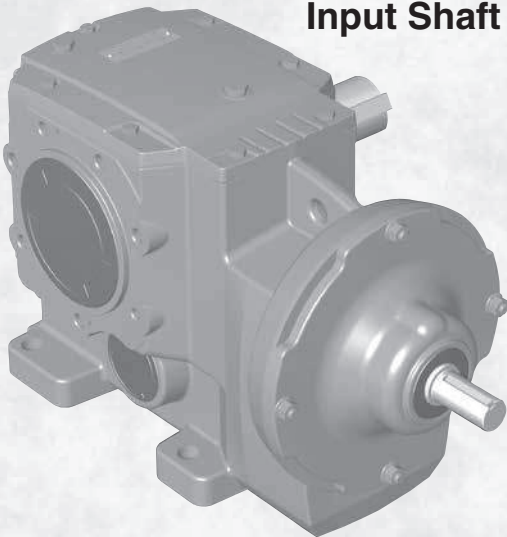

**Top Mount**

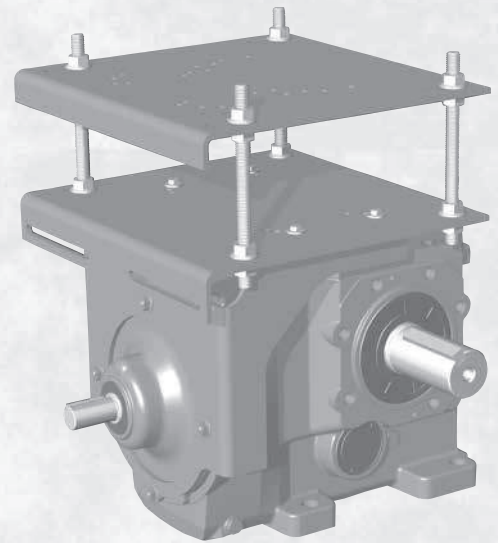

**Scoop Mount**

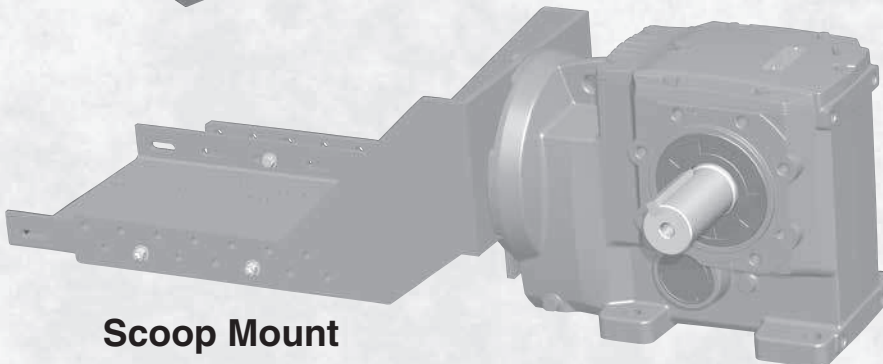

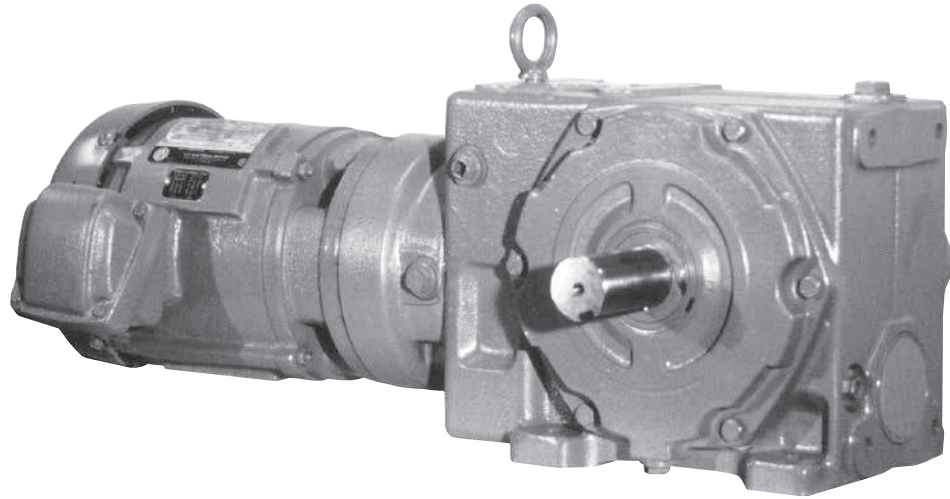

OtN Series

**Gearmotor Section .....Page B-6 - B-117**

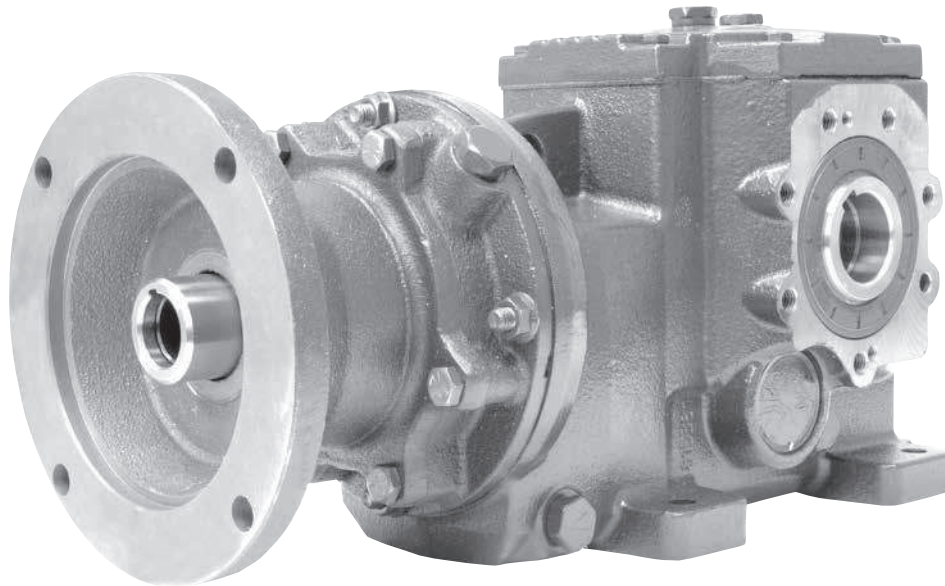

**Reducer Section .....Page B-118 - B-244**



**Mounting Versatility and Size Range**

OtN Series

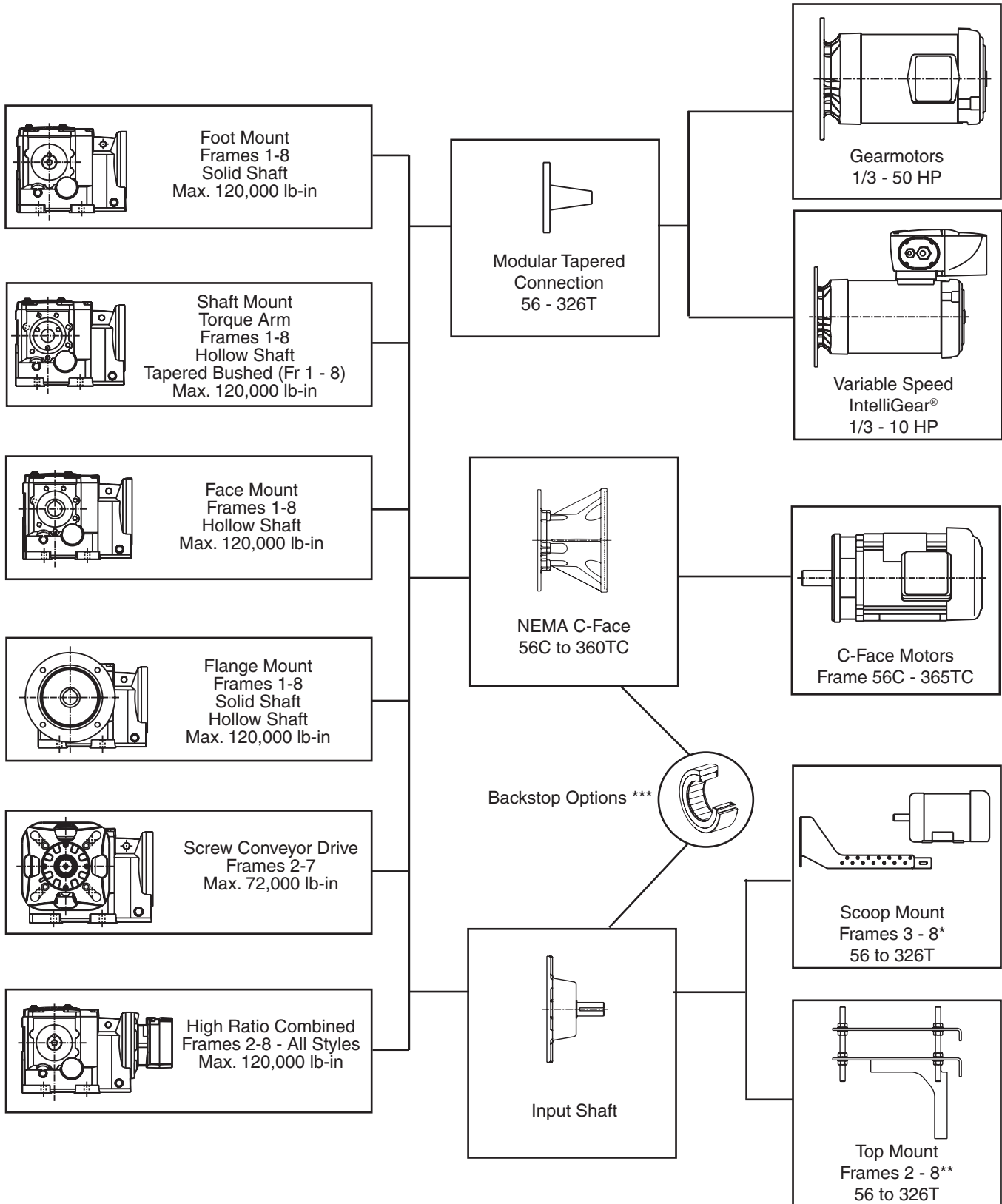

\* Not available for frames 2 - 5, 5-stage or frames 4 - 6, 6-stage.

\*\* Only available for frames 3 - 8, 3-stage and frame 2 in 2 stage. On frame 8 the Top Mount construction requires production lead-time.

\*\*\* Not available for frames 3245 and 3365A. Available input shaft or scoop mount only for frames 6 - 8.



**General Information****General**

OtN helical-bevel right angle gearmotors and speed reducers incorporate the latest in design and manufacturing technologies to deliver an energy efficient, reliable, helical-bevel gear train. This gearing can be combined with either a constant or variable speed motor if a gearmotor is desired. The latest generation of OtN gearing is 98% efficient per gear stage, with two, three, five or six stages available for ratios of 3.55:1 to 10,000:1. OtN is available in a wide variety of mounting arrangements that include foot mount, face mount, flange mount or shaft mount with a torque arm. The output can be left, right, or dual solid shaft or shaft mounted with hollow quill or new tapered bushed.

**Gearmotors**

Three phase OtN gearmotors are available with HE type high efficiency motors in non-hazardous enclosures starting at 1/3 HP at standard lead-times. These motors comply with requirements in the US and Canada for energy efficiency to deliver superior operating cost savings, reduced motor temperature rise and 5:1 minimum constant torque output (60-11 Hz) from PWM power supplies for the End User. There are several motor enclosure options within the HE umbrella including Corro-Duty® cast iron exterior construction for most hostile environments. These features are complimented by the standard use of inverter duty winding materials that comply with NEMA MG1 Part 31. Emerson also offers gearmotors with 1 phase TEFC motors to 5 HP and Explosionproof 3 phase gearmotors to 10HP.

**Housing**

The unique housing design allows the OtN3000 to directly interchange with many popular competitive products, while offering a version that also replaces the OtN2000 sizes that it replaces. This allows for simple aftermarket replacement of both OtN2000 and many of the more common helical-bevel products from other manufacturers. All housings are cast from high-strength cast iron. Additionally, the new, quill style c-face of OtN3000 is often shorter than competitive designs, while allowing room for a fully rated backstop.

**Performance**

OtN designs deliver ratings that are amongst the highest in the industry for similar frame sizes. For replacements, this means that dimensional replacements generally meet or exceed the original unit ratings for long life. In new applications, this can mean cost savings through downsizing versus the competition. Each OtN unit is

also supplied factory-filled with high quality synthetic lubricant, an extra cost option for competitive units. This offers operation over a wide temperature range with minimal maintenance required.

**Screw Conveyor Drives**

The OtN3000 units may be ordered in a CEMA screw conveyor drive version. The same variety of screw conveyor drive shafts, sealing cartridges and trough ends are available as the Browning TorqTaper® Plus shaft mount product line. Now there's a screw conveyor drive available with a full range of gear ratios and a gearmotor, c-face, input shaft, scoop mount or top mount input. The standard tapered roller bearings in this version provide heavy thrust load capability - an important feature for many screw conveyor applications.

**Flexibility**

The new OtN3000 offers a shaft-mounted version that incorporates the tapered bushing system from the Browning TorqTaper Plus shaft mount reducer. This extends each frame size to be usable on a variety of shaft sizes. It also provides a proven bushing system with a centering ring that reduces wobbling on the shaft for reduced wear and tear. All sizes are also available with a hollow quill sized to match popular competitive units. The bushed version of OtN3000 includes a bushing to match the OtN2000 equivalent frame size for replacements. The shaft-mounted units all include feet on the housing base and they can be tied down to the machine frame using a face mount, flange mount, or torque arm. There are two flanges available for most OtN3000 frame sizes, one of which is competitively interchangeable. Also, for applications requiring the gearmotors to be powered by an inverter (VFD), all Allguard® three phase motor designs now incorporate an upgraded wire and varnish treatment. Housings can be mounted in a variety of positions as well, with only a change in the breather and drain plug positions and a change in oil volume.

**Reliability**

Gear housing sizes 1-5 are fitted with normally closed breathers to exclude contaminants, while preserving low internal operating pressure. All oil seals operate on plunge ground shaft surfaces to deliver extended life. Enhanced insulating materials and other standard features of our premium Varidyne® inverter duty motors allow Emerson to extend an industry leading 3-year motor warranty, even when using these motors with PWM inverter power up to 575 VAC.

# Table of Contents

Section	Page
Design Features .....	B-7
Mounting Versatility and Size Range .....	B-8
Motor Options .....	B-9
Gearmotor Selection (constant speed).....	B-10 - B-11
Gearmotor Selection (IntelliGear).....	B-12 - B-13
Catalog Nomenclature.....	B-14 - B-17
Gearmotor Mounting Positions .....	B-16
Gearmotor Output Brackets and Shafts .....	B-15
Standard Motor Input Types.....	B-17
Electrical Connection Options .....	B-18
Modifications, Options and Accessories.....	B-19 - B-21
Torque Reaction Arms.....	B-22 - B-23
Screw Conveyor Accessories .....	B-24 - B-25
Tapered Bushing Selections.....	B-26
AGMA Application Classifications .....	B-27 - B-29
Gearmotor Selection Tables .....	B-30 - B-62
Dimension Prints with Standard TEFC Motors	
Output Shafted Foot Mount.....	B-63 - B-69
Output Shafted Flange Mount.....	B-70 - B-76
Finished Bore Hollow Shaft.....	B-77 - B-83
Finished Bore Hollow Shaft Face Mount.....	B-84 - B-90
Finished Bore Hollow Shaft Flange Mount.....	B-91 - B-97
Taper Bushed Shaft Mount.....	B-98 - B-104
Screw Conveyor Drives.....	B-105 - B-111
Flanged Drop Bearing.....	B-112 - B-113
Alternate Motor End Dimension.....	B-114 - B-115
Motor Brake Dimension Supplement.....	B-116
Gearmotor Weights.....	B-117
Lubrication.....	B-243
Gearmotor - Typical Motor Performance Data .....	F-1 - F-7
IntelliGear® Technical Specifications .....	F-8 - F-12
NEMA Standard Dimensions.....	F-13
General Information.....	F-14
Standard Terms and Conditions of Sale .....	F-15

## Type OtN Helical-Bevel Series 3000 Gearmotor Features...

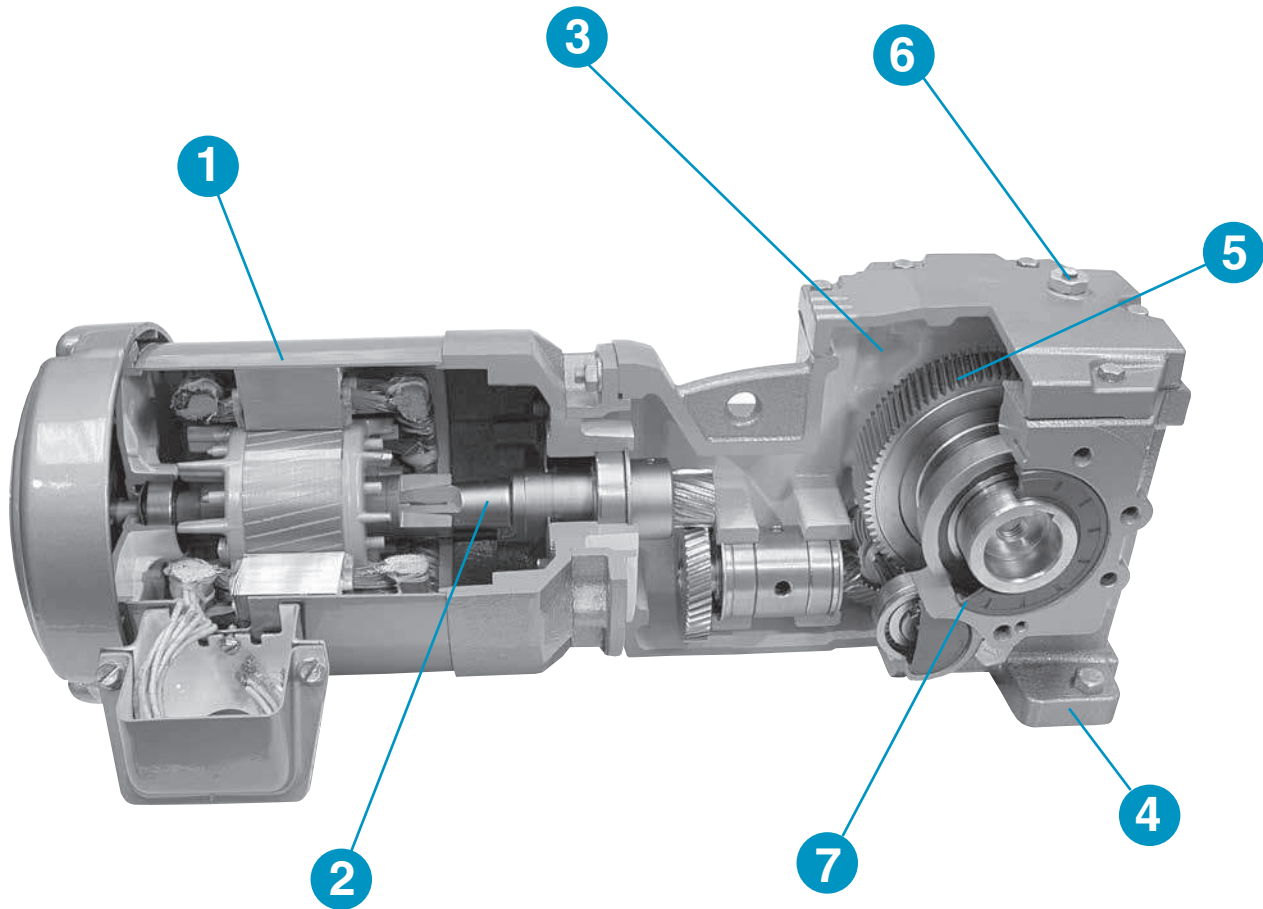

### Design Features

- 1. High Efficiency Motor Design Available**
  - Any 3 phase non-XP gearmotor.
- 2. Innovative Self-Locking, Self-Aligning Taper Shaft Motor Connection**
  - Easy on-site motor replacement.
  - Change motor without draining oil, breaking the gearcase seal, or changing primary pinion.
- 3. Gearbox Supplied Factory Filled with Synthetic Oil**
  - Wide temperature range and longer life.
- 4. Corrosion and Shock Resistant Cast Iron Housing**
  - One piece, reinforced and ribbed for extra strength.
- 5. High Efficiency Helical-Bevel Gears. 98% per Stage**
  - Helical gearing is case hardened and then skived, superfinished or ground.
  - All gears heat shrunk on shafts or mounted on self-locking tapered shafts and keyed for high shock load capability.
- 6. Normally Closed Breather with Multiple Locations**
- 7. Double Lip Seals on Heat Treated, Plunge Ground Shafts**



**Mounting Versatility and Size Range**

OtN Series

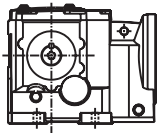

Foot Mount  
Frames 1-8  
Solid Shaft  
Max. 120,000 lb-in

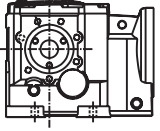

Shaft Mount  
Torque Arm  
Hollow Shaft  
Tapered Bushed  
Frames 1-8  
Max. 120,000 lb-in



Face Mount  
Frames 1-8  
Hollow Shaft  
Max. 120,000 lb-in

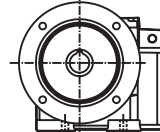

Flange Mount  
Frames 1-8  
Solid Shaft  
Hollow Shaft  
Max. 120,000 lb-in

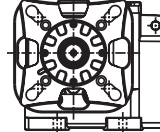

Screw Conveyor Drive  
Frames 2-7  
Max. 72,000 lb-in

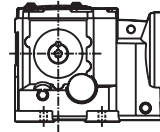

High Ratio Combined  
Frames 2-8 - All Styles  
Max. 120,000 lb-in

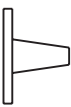

Modular Input Assembly  
Tapered Connection

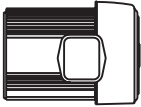

Three Phase TEFC  
1/3 – 50 HP

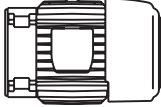

Corro-Duty®  
1/3 – 50 HP

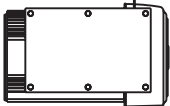

Single Phase TEFC  
1/3 – 5 HP



Explosion Proof  
1/3 – 10 HP



Brakemotor  
1/3 – 10 HP



IntelliGear® Motor  
with VFD  
1/3 – 10 HP

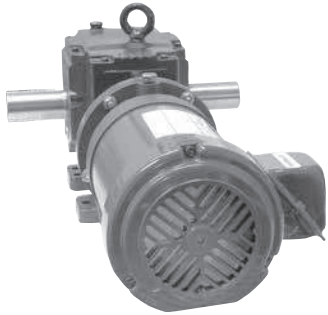

### TEFC – Three Phase

- Suitable for general purpose industrial applications
- High efficient design standard
- 1.25 service factor through 5 HP; 1.15 service factor above 5 HP
- Available for 50 Hz, 190/380 VAC through 30 HP
- Premium class F Allguard® insulation standard
- Premium efficiency available as option 3 HP and larger
- Inverter duty option per NEMA MG1 part 31 stocked
- Washdown gearmotor available to 2 HP

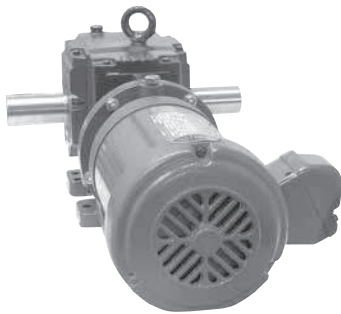

### Corro-Duty®

- Designed for wet, corrosive applications and industries including waste treatment, mining and lumber.
- All cast iron construction (56 and 140 frames are rolled steel)
- High efficiency standard 1/3 HP and above
- Premium efficient option 3 HP and larger
- 1.15 service factor, class F Allguard motor insulation
- Condensation drains in motor and conduit box
- 40°C ambient, NEMA design B, continuous duty
- Inverter duty version per NEMA MG1 part 31 stocked to 20 HP



### TEFC – Single Phase

- For agricultural, light material handling, textile, and light pumping applications
- 1.25 service factor  
(1.0 service factor, 2 HP and 1.15 service factor, 3 - 5 HP)
- Capacitor start  
(capacitor run above 1/2 HP, 48 frame)  
(capacitor run above 1/2 HP, 56 – 180T frames)
- Class B insulation, continuous duty, reversible

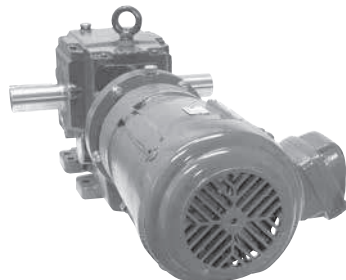

### Explosion Proof

- Ideal for the petro-chemical, grain, mining, and chemical industries
- Class I, group D, class II, groups F and G
- All cast iron construction (plastic fan cover)
- 1.0 service factor, class B insulation
- 40°C ambient, NEMA B design, continuous duty
- UL\* approved Inverter duty per NEMA MG1 part 31 available

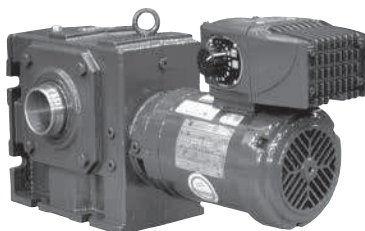

### IntelliGear®

- Variable speed gearmotor with NEMA 4/12 enclosure
- "Onboard" push button and remote speed changing options
- Pre-programmed 6:1 constant torque speed range
- Versions for 3/460V input power supplies from 1/3 to 10 HP
- 1/230V and 3/230V to 5 HP
- 1/115 V through 3/4 HP
- UL, CUL and CE
- Optional 10:1 and 15:1 speed ranges

## Selection Information

1. Input HP
  - Based on application data
2. Speed / ratio
  - Obtain either desired output speed (RPM) or gearbox ratio based on application.
3. Mechanical service factors - gears
  - There are three standard classifications for gearmotor applications:

Class I - uniform loading, 3-10 hours per day, service factor 1.0 (minimum).

Class II - uniform loading over 10 hours per day or moderate shock loading up to 10 hours per day; service factor 1.4 (minimum).

Class III - moderate shock loading over 10 hours per day or heavy shock loading up to 10 hours per day; service factor 2.0 (minimum).

- The tables on pages B-27 through B-29 are based on past operating experience within the industries listed and information gathered by AGMA. If the user has data reflecting greater severity than normal industry usage, then the AGMA class should be increased.
- Choose the AGMA class for your given application based on this criteria. If your application cannot be found, use the following table to determine the service factor.

Duty Cycle	Hours Operation	Uniform	Moderate	Heavy
		Load <b>U</b>	Shock Load <b>M</b>	Shock Load <b>V</b>
Continuous	0 - 3	0.80	1.00	1.50
	3 - 10	1.00	1.25	1.75
	10 - 24	1.25	1.50	2.00
Frequent Starts/Stops*	0 - 3	1.00	1.25	1.75
	3 - 10	1.25	1.50	2.00
	10 - 24	1.50	1.75	2.25

\*Greater than 10 per hour

## Size Selection

Step 1 - Locate gearmotor selection tables (pages B-30 - B-62) based on motor HP.

Step 2 - Choose the appropriate nominal speed or ratio required.

Step 3 - Select the correct gearmotor based on AGMA class or service factor determined from selection information.

Step 4 - Verify overhung load ratings where required (see below).

## Overhung Load

When a sprocket, sheave, pulley, or pinion is mounted on the take-off shaft of a gearmotor, it is necessary to calculate the overhung load. This calculated load must be compared with the gearbox capacity listed to make sure the gearbox will not be overloaded. To calculate the overhung load you need to know the torque or horsepower at the take-off shaft and the location along the shaft at which the load is applied.

A. If torque is known:

$$OHL = \frac{T \times K \times LLF}{r}$$

B. If horsepower is known:

$$OHL = \frac{63025 \times HP \times K \times LLF}{rpm \times r}$$

Where:

OHL = Overhung load (pounds)

T = Torque (in. lbs.)

r = Radius of driving member (in.)

HP = Horsepower

K = Drive type factor

LLF = Load location factor

Driving Member	Value of K
Chain Drive	1.00
Pinion	1.25
V-Belt	1.50
Timing Belts	1.25

Load Location	Value of LLF
End of shaft extension	1.20
Center of shaft extension	1.00
Shaft extension shoulder	0.80



**Selection Example**

A right angle, foot mounted gearmotor is required to operate a uniformly loaded belt conveyor at 30 RPM, 24 hours per day. An 11" diameter sprocket is mounted at the end of the shaft and drives the conveyor with a chain drive. The customer has specified a 230/460 VAC, 3-phase, TEFC high efficiency motor rated 5 HP. Shaft extension is to be on the right, viewing the motor fan cover. The unit will be in the normal floor mounted position with the motor horizontal and the mounting feet on the bottom.

Refer to AGMA service classification table on page B-27.

Application	Load	Class	
<b>Conveyors</b> – Uniformly Loaded or Fed: Apron, Assembly, Belt, Bucket, Chain, Flight, Oven, Screw	U	Up to 10 Hrs/Day	Over 10 Hrs/Day
		I	II

Since this application operates 24 hours per day, a Class II service factor is required.

**Step 1...** Locate a gearmotor for 5 HP on page B-50.

**Step 2...** Find a nominal speed closest to the 30 RPM output required.

**Step 3...** Select the row in the table for Class II service factor.

Output rpm	AGMA	Service Factor	Output Torque in-lb	OHL lb	Nominal Ratio	Frame Size		Std. Motor Types
	Class					Gear	Motor	
31	I,II	1.4	9661	2875	56	3473	184T	T,C,S,X,IG
28	I	1.3	10491	2875	63	3473	184T	T,C,S,X,IG

30 rpm falls between these two lines in the selection table, but the 28 rpm line doesn't meet the Class II service factor requirement. Size 3473 gear frame with 56:1 nominal ratio and 31 rpm output is the best selection.

**Step 4...** Verify that the Overhung Load Rating is sufficient for the applied load.

$$r = \frac{\text{Sprocket Diameter}}{2} = \frac{11}{2} = 5.5"$$

$$K = 1.0 \text{ (chain drive)}$$

$$LLF = 1.2 \text{ (sprocket on end of shaft)}$$

$$HP = 5$$

$$OHL = \frac{63025 \times HP \times K \times LLF}{\text{rpm} \times r} = \frac{63025 \times 5 \times 1.0 \times 1.2}{31 \times 5.5} = 2217.9 \text{ lbs.}$$

Since the gearmotor output OHL rating is 2875 lbs (see selection table) and this is greater than the applied OHL of 2217.9 lbs, the selection is fine. If the OHL rating was too low, the sprocket diameter or gear frame could be increased.

**Complete the Process by Building a Complete Part Number**

Catalog designation (see "Catalog Nomenclature" page B-14):

**OtN • 3473 • S2 • B33G • 56 • HT24 • 184T • 5**

The codes indicate the following: Frame 3473 OtN Gearmotor, S2 = the standard output shaft and mounting dimensions, B = Floor Mount, 33 = No Faces or Flanges, G = Single Shaft on Right Facing Motor Fan, 56:1 Ratio, HT24 = High efficiency TEFC Motor, 184T Motor Frame, 5 HP. (Page B-16 shows mounting positions, page B-15 explains output shaft and face or flange positions, and page B-17 shows motor types.)

## Gearmotor Selection

### Selection Information

### Size Selection

1. Determine installation environment
  - Control enclosure is NEMA 4/12
2. Input HP
  - For constant torque loads this is at maximum speed of range. Therefore, the gear ratio should be selected to closely match the required maximum speed.
3. Speed range
  - Confirm maximum and minimum of needed range.
4. Determine control power supply
  - Phase and voltage

Power Supply	Input HP's
1 ph / 115 v	.33 to .75
1 ph / 230 v	.33 to 2
3 ph / 230 v	.33 to 5
3 ph / 460 v	.33 to 10
3 ph / special	R. O.

5. Mechanical service factoring of gear
  - Refer to page B-10 for this procedure.

Note: IntelliGear application for 1 phase power supply is limited to 10 starts per hour where the unit is started via AC power mains contractor.
6. Determine speed adjustment option
  - Select from:
    - PD = Digital keypad with forward/reverse/stop/speed up/speed down/speed display on IntelliGear enclosure
    - P1 = Run/stop/speed pot. mounted on IntelliGear enclosure
    - P2 = Forward/reverse/stop/pot. mounted on IntelliGear enclosure
    - P3 = Speed pot. (only) mounted on IntelliGear enclosure (start/stop by others)
    - P4 = Speed pot. (only) mounted inside IntelliGear enclosure (start/stop by others)
    - R = Remote signal following (0-10VDC or 4-20mA supplied by others)

- Step 1 - Determine the maximum motor rpm from the following table based on the whether the application requires a speed range of 6:1, 10:1 or 15:1.

$$\text{Speed Range} = \frac{\text{Maximum Output Speed Required}}{\text{Minimum Output Speed Required}}$$

HP	IntelliGear Motor Speed Range		
	6:1 Speed Range	10:1 Speed Range	15:1 Speed Range
1/3 - 3/4 HP	1760 - 293 rpm	1760 - 176 rpm	2625 - 175 rpm
1 - 1 1/2 HP	1750 - 291 rpm	1750 - 175 rpm	2620 - 175 rpm
2 HP	1750 - 291 rpm	2585 - 255 rpm	N. A.
3 HP	1750 - 291 rpm	2630 - 263 rpm	N. A.
5 HP	2150 - 358 rpm	2605 - 260 rpm	N. A.
7.5 HP	2150 - 358 rpm	2670 - 267 rpm	N. A.
10 HP	2100 - 350 rpm	2600 - 260 rpm	N. A.

- Step 2 - Determine the gear ratio required. Use the maximum motor rpm from the table above.
- $$\text{Gear Ratio} = \frac{\text{Maximum Motor Speed}}{\text{Maximum Output Speed Req'd.}}$$
- Step 3 - Locate gearmotor selection tables based on the input HP required at the ratio calculated in Step 2. Select the nominal gear ratio closest to the one calculated.
- Step 4 - Select the correct gearmotor that meets or exceeds the AGMA class or service factor determined in the selection information.
- Step 5 - Verify overhung load rating where applicable per formulas on page B-10.
- Step 6 - Confirm input power supply is compatible with HP of selection and select the speed adjustment option desired for the application.
- Step 7 - Referring to page B-18, determine if an alternative controller location is required for the application. (Note that the default location is "FO" – the 12 o'clock position.)

**Selection Example**

A right angle, flange mounted gearmotor is required to operate a mixer for a variable density solution. The mixer operates 8 hours per day, and the speed range is 12-56 rpm. The mixer shaft will be directly coupled to the gearmotor output shaft on the right side viewed from the motor end. The customer has specified a 2 HP gearmotor with a TEFC motor, and the power supply is 460 VAC, 3-phase. The flange is to be located on the right, viewing the motor fan cover, and the OD required is 250 mm. The unit will be mounted on its side with the motor horizontal and the output shaft vertical down. Viewed from the top of the gearcase housing, the motor will be mounted to the right.

Refer to AGMA service classification table on page B-28.

Application	Load	Class	
		Up to 10 Hrs/Day	Over 10 Hrs/Day
<b>Mixers (Also see Agitators):</b>			
Concrete - Continuous	M	II	II
Concrete - Intermittent	M	I	-
Constant Density	U	I	II
Variable Density	M	II	II

Since this mixer is variable density and operates 8 hours per day, a Class II service factor is required.

**Step 1...** Calculate the speed range required: 56 rpm max./12 rpm min. = 4.7:1, so an IntelliGear with 6:1 range is required. This means the motor top speed will be 1750 rpm for a 2 HP IntelliGear.

**Step 2...** The ideal gear ratio is 1750 rpm / 56 rpm = 31.25:1.

**Step 3...** Locate gearmotor for 2 HP on page B-44, and find a nominal ratio close to 31.25:1.

**Step 4...** Select the row in the table for Class II service factor.

Output rpm	AGMA Class	Service Factor	Output Torque in-lb	OHL lb	Nominal Ratio	Frame Size Gear	Motor	Std. Motor Types
57	III	3+	2072	2090	31.5	3363	145T	T,C,S,X,IG
56	I, II	1.5	2178	2071	31.5	3242	145T	T,C,S,X,IG
53	III	3+	2228	2090	35.5	3363	145T	T,C,S,X,IG

Note that 31.25:1 ratio is closest to 31.5:1 nominal ratio. There are two choices at this ratio, and both meet the Class II service factor requirement. This means that the smaller Size 3242 gear frame will be the most economical selection.

**Step 5...** For a direct coupled application, it is not necessary to consider the Overhung Load Rating.

**Step 6...** The power supply is 460 VAC/3-phase, and there is an IntelliGear available for this voltage at 2 HP. (See the footnote at the bottom of page B-44.)

**Complete the Process by Building a Complete Part Number**

Catalog designation (see "Catalog Nomenclature" page B-14):

**OtN • 3242 • S2 • T63G • 31.5 • IG4 • 145T • 2**

The codes indicate the following: Frame 3242 OtN Gearmotor, S2 = the standard output shaft and mounting dimensions, T = Flange mount with output shaft down, 63 = Flange on right side, G = Single Output Shaft on the right side, 31.5:1 Nominal Ratio, IG4 = 460 VAC/3-Phase IntelliGear, 145T Motor Frame, 2 HP. (Page B-16 shows mounting positions, page B-15 explains output shaft and face or flange positions, and page B-17 shows motor types.)



OtN • 34 7 3 • S2 • B 33 G • 22.4 • HT24 • 145T • 1.5 • G11

See pages B-15 - B-16

OtN Series

Browning Right-Angle Helical-Bevel	Series	Reducer Size	Stages	Shaft & Foot Dimensions <sup>1</sup>	Mounting Position	Output Face/Flange Right-Left Viewed From Input End	Output Shaft Configuration Viewed from Input End	Nominal Gear Ratio	Input Type	Motor Frame	Motor HP	Modification(s)
SERIES 3000		31	3	2= 2 stages	S2 = Industry interchange dimensions	B = Floor mount	3 = Standard round	22.4 = 22.4:1  Use nominal ratio selected from gearmotor selection tables	Motor type selected from catalog designations column in standard motor input from table on page B-17			Select from modifications listed on pages B-18 to B-21
		32	4	3(A) = 3 stages		P = Ceiling mount	4 = Face mount					
		33	6	5 = 5 stages		H = Wall mount, input left	5 = Standard dimension flange mount					
		34	7	6 = 6 stages	S1 = OtN2000 replacement dimensions	T = Wall mount, input right	6 = Alternate dimension flange mount					
		35	8			V = Input vertical up	7 = Screw conveyor adapter					
		36	9			W = Input vertical down						
		37	0									
		38	2									

<sup>1</sup> Shaft and critical mounting dimensions match either OtN2000 or SEW® "K" Series units. These dimensions include the mounting base, output flanges, output shaft diameter, distance from housing center line to shaft tip, and output quill diameter. The B14 mounting faces and overall product envelope (height, width, depth) do NOT match.

SEW is believed to be a trade name of SEW-Eurodrive GMBH & Co. and is NOT owned or controlled by Emerson. Emerson cannot and does not represent or warrant the accuracy of this information.

Output Flange Sizes											
Flange Dimensions (mm)											
<b>BD</b>	140	165	200	250	300	350	400	450	550	660	
<b>AK</b>	95	110	130	180	230	250	300	350	450	550	
<b>AJ</b>	115	130	165	215	265	300	350	400	500	600	
<b>Gear Frame</b>	<b>Output Flange Type Designation Code</b>										
<b>31</b>	6	5									
<b>32</b>			5	6							
<b>33</b>				5	6						
<b>34</b>					5	6					
<b>35</b>						5	6				
<b>36</b>								5	6		
<b>37</b>									5	6	
<b>38</b>										5	6

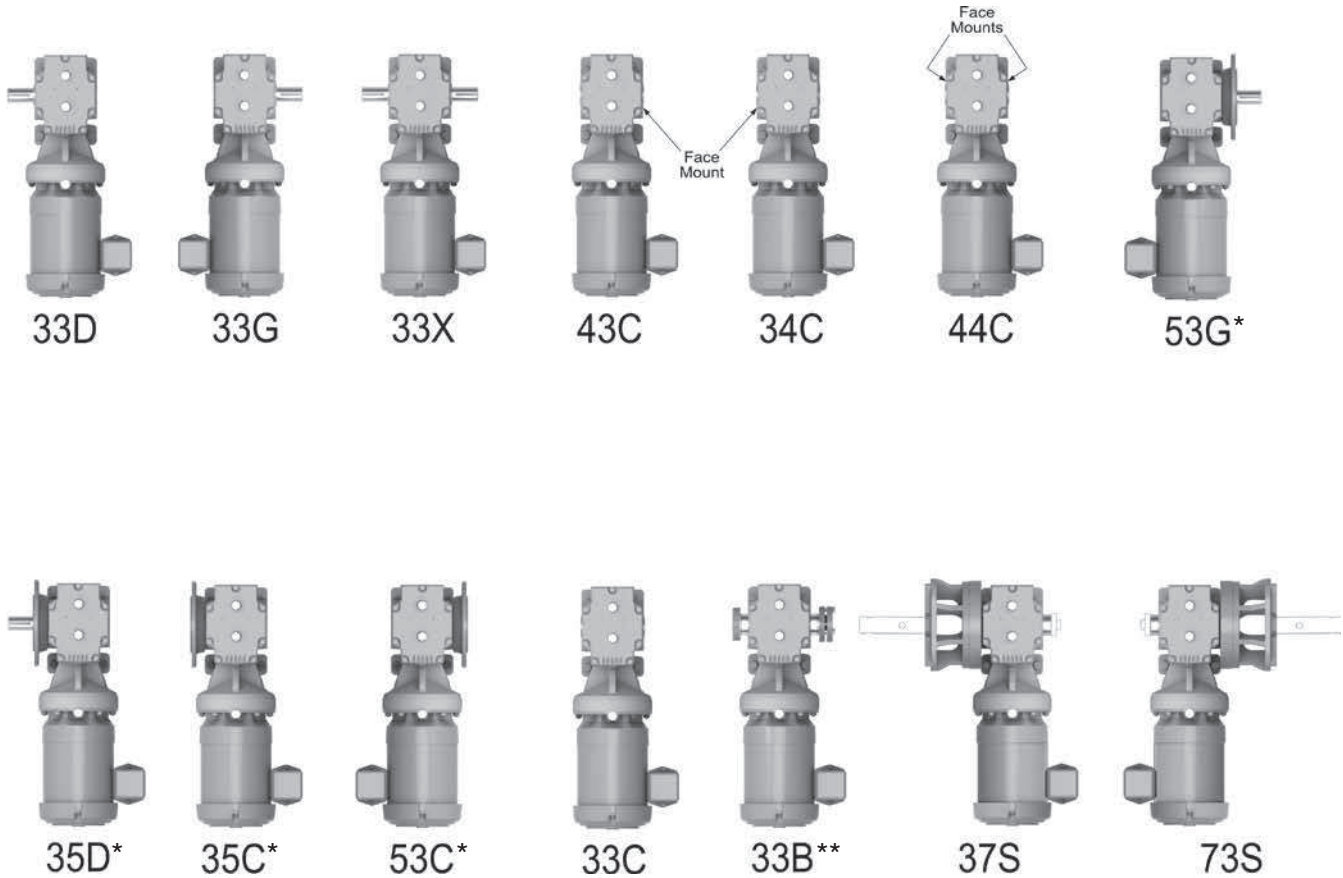

**Examples Above are Top Views**

OtN Frame	Foot Mounted			Face Mounted				Flange Mounted					Shaft Mounted		Screw Conveyor Drive		
	Solid Shaft			Hollow Shaft				Solid Shaft		Hollow Shaft			Hollow	Bushed	73S	37S	
	33G	33D	33X	33C	34C	43C	44C	53G	35D	53C	35C	55C	33C	33B**			
31	●	●	●	●	●	●	●	●	●	●	●	●	●	●	●	-	-
32	●	●	●	●	●	●	●	●	●	●	●	●	●	●	●	●	●
33	●	●	●	●	●	●	●	●	●	●	●	●	●	●	1	●	●
33A	-	-	-	-	-	-	-	-	-	-	-	-	-	●	-	-	
34	●	●	●	●	●	●	●	●	●	●	●	●	●	●	●	●	●
35	●	●	●	●	●	●	●	●	●	●	●	●	●	●	●	●	●
36	●	●	●	●	●	●	●	●	●	●	●	●	●	●	●	●	●
37	●	●	●	●	●	●	●	●	●	●	●	●	●	●	●	●	●
38	●	●	●	●	●	●	●	●	●	●	●	●	●	●	●	-	-

If shaded, the alternative flange can be specified by replacing "5" with "6" in the coding

- This is available at normal lead-time
- \* See note for shaded field for flange option
- \*\* Bushing can be assembled on either side of reducer during field mounting
- 1 Effective 2/1/10 the frame 33 bushed design will be using the 33A frame and 115 SMTP bushing system

**Foot Mount**

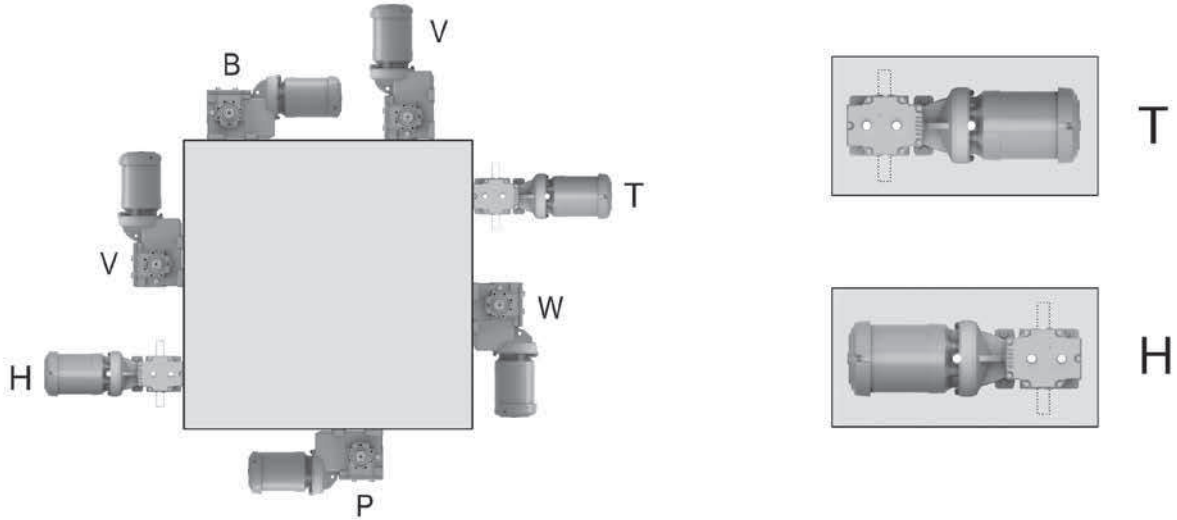

**Foot Mount with Face or Flange**

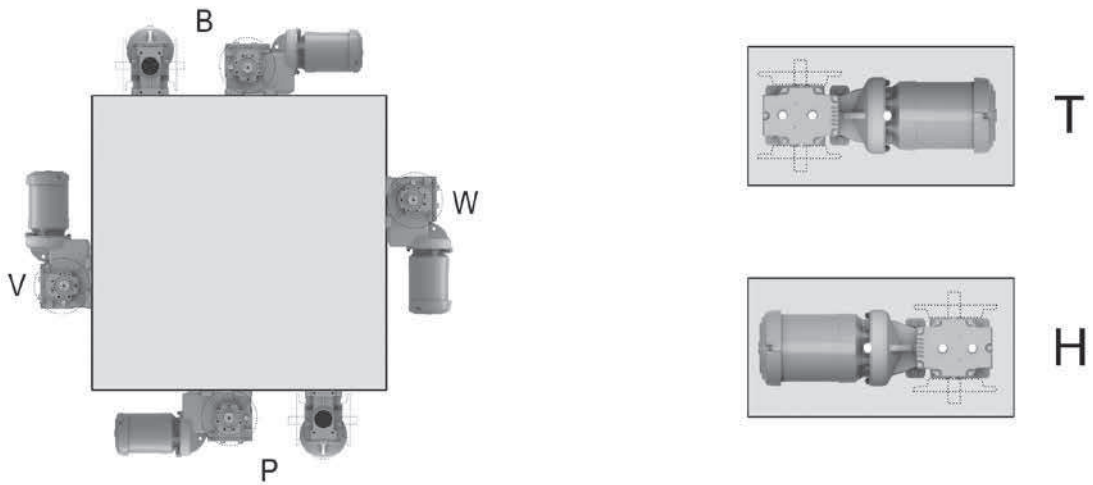

**Flange, Face or Shaft Mount**

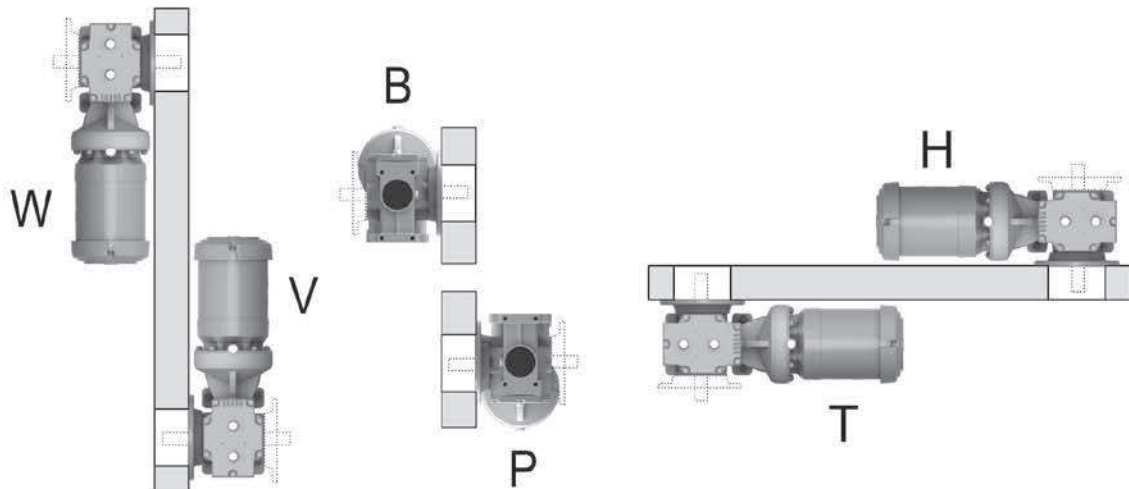

Example: High Efficiency, TEFC, 3 phase 60 Hz, 575V, with Fail-safe Brake

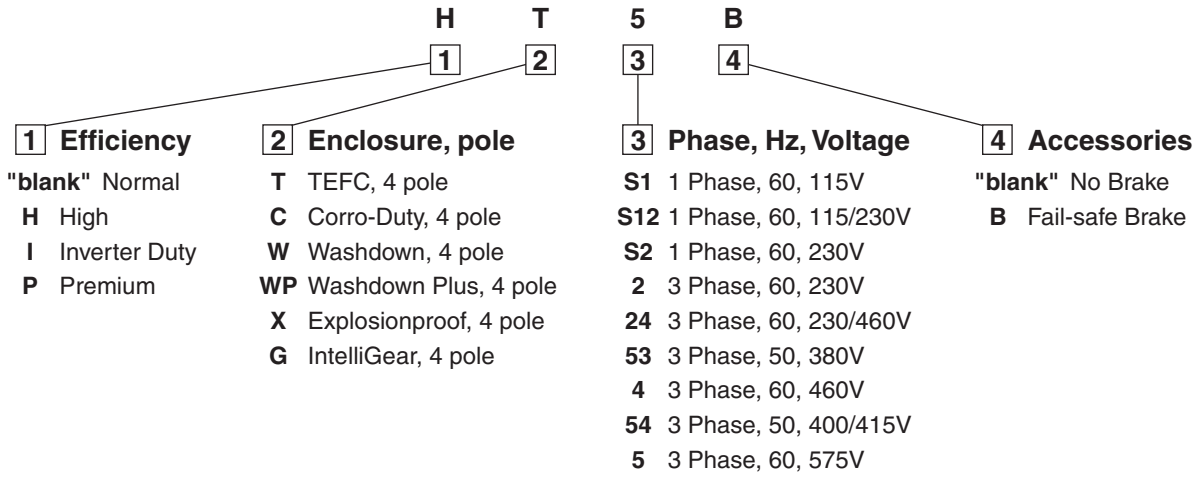

Base Design	Input Code	Motor HP															
		0.33	0.50	0.75	1	1.5	2	3	5	7.5	10	15	20	25	30	40	50
S Single Phase TEFC	TS12	Y	Y	Y	Y	Y	Y	-	-	-	-	-	-	-	-	-	-
	TS12B	Y	Y	Y	Y	Y	Y	-	-	-	-	-	-	-	-	-	-
	TS2	-	-	-	-	-	-	Y	Y	-	-	-	-	-	-	-	-
	TS2B	-	-	-	-	-	-	Y	Y	-	-	-	-	-	-	-	-
T 3 Phase TEFC	HT24	Y	Y	Y	Y	Y	Y	Y	Y	Y	Y	Y	Y	Y	Y	Y	Y
	HT24B	Y	Y	Y	Y	Y	Y	Y	Y	Y	Y	-	-	-	-	-	-
	HT5	Y	Y	Y	Y	Y	Y	Y	Y	Y	Y	Y	Y	Y	Y	Y	Y
	HT5B	Y	Y	Y	Y	Y	Y	Y	Y	Y	Y	-	-	-	-	-	-
	T24	Y	Y	Y	Y <sup>1</sup>	Y	Y	Y	Y	Y	Y	-	-	-	-	-	-
	T24B	Y	Y	Y	Y <sup>1</sup>	Y	Y	Y	Y	Y	Y	-	-	-	-	-	-
	T5	Y	Y	Y	Y <sup>1</sup>	-	-	-	-	-	-	-	-	-	-	-	-
	T5B	Y	Y	Y	Y <sup>1</sup>	Y	Y	Y	Y	Y	Y	-	-	-	-	-	-
	T53	Y	Y	Y	Y <sup>1</sup>	Y	Y	Y	Y	Y	P	P	P	P	P	P	P
	T54	Y	Y	Y	Y	Y	Y	Y	Y	Y	P	P	P	P	P	P	P
	IT24	Y	Y	Y	Y	Y	Y	Y	Y	Y	Y	Y	Y	Y	Y	Y	Y
	IT24B	Y	Y	Y	Y	Y	Y	Y	Y	Y	-	-	-	-	-	-	-
	IT5	Y	Y	Y	Y	Y	Y	Y	Y	Y	Y	Y	Y	Y	Y	Y	Y
	IT5B	Y	Y	Y	Y	Y	Y	Y	Y	Y	-	-	-	-	-	-	-
	PT24	-	-	-	-	-	-	Y	Y	Y	Y	Y	Y	Y	Y	Y	Y
	PT5	-	-	-	-	-	-	Y	Y	Y	Y	Y	Y	Y	Y	Y	Y
	W24	Y	Y	Y	Y <sup>1</sup>	Y	Y	-	-	-	-	-	-	-	-	-	-
	W5	Y	Y	Y	Y <sup>1</sup>	Y	Y	-	-	-	-	-	-	-	-	-	-
WP24	Y	Y	Y	Y <sup>1</sup>	Y	Y	-	-	-	-	-	-	-	-	-	-	
WP5	Y	Y	Y	Y <sup>1</sup>	Y	Y	-	-	-	-	-	-	-	-	-	-	
C 3 Phase Corro-Duty®	HC24	Y	Y	Y	Y	Y	Y	Y	Y	Y	Y	Y	Y	Y	Y	Y	
	HC5	Y	Y	Y	Y	Y	Y	Y	Y	Y	Y	Y	Y	Y	Y	Y	
	IC24	Y	Y	Y	Y	Y	Y	Y	Y	Y	Y	Y	Y	Y	Y	Y	
	IC5	Y	Y	Y	Y	Y	Y	Y	Y	Y	Y	Y	Y	Y	Y	Y	
	PC24	-	-	-	-	-	-	Y	Y	Y	Y	Y	Y	Y	Y	Y	
PC5	-	-	-	-	-	-	Y	Y	Y	Y	Y	Y	Y	Y	Y		
X 3 Phase Explosionproof	X24	Y	Y	Y	Y	Y	Y	Y	Y	Y	-	-	-	-	-	-	
	X5	Y	Y	Y	-	-	-	-	-	-	-	-	-	-	-	-	
IG IntelliGear®	IX24	P	P	P	P	P	P	P	P	P	-	-	-	-	-	-	
	IGS1	Y	Y	Y	-	-	-	-	-	-	-	-	-	-	-	-	
	IGS2	Y	Y	Y	Y	Y	Y	-	-	-	-	-	-	-	-	-	
	IG2	Y	Y	Y	Y	Y	Y	Y	Y	-	-	-	-	-	-	-	
	IG4	Y	Y	Y	Y	Y	Y	Y	Y	Y	Y	-	-	-	-	-	

P = Production lead-time    Y = Available from stock    Y<sup>1</sup> = Motor frame is B56    - = not available



## Electrical Connection Options

### Conduit Box Location

When ordering a conventional OtN gearmotor, specify the desired conduit box location when viewing fan cover guard of motor. If no option is specified, the conduit box location per gearbox mounting will be supplied as shown in the table below.

Output Arrangement	Standard Conduit Box Location
33D, 35D, 36D, 33X, 55X, 66X, 33B, 33C, 34C, 44C, 35C, 36C, 55C, 66C, 73S	F-1
33G, 53G, 63G, 43C, 53C, 63C, 73S	F-2

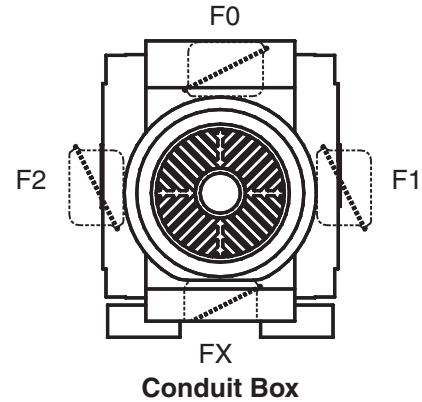

### Controller Location

When ordering an IntelliGear® Series 2000 or 3000 gearmotor, you can specify the controller location and conduit entry location when viewing the fan cover guard of motor. If no options are specified, the "F0" controller location will be supplied.

\* Refer to Application Engineering for de-rating guidance in the F1 or F2 IntelliGear locations.

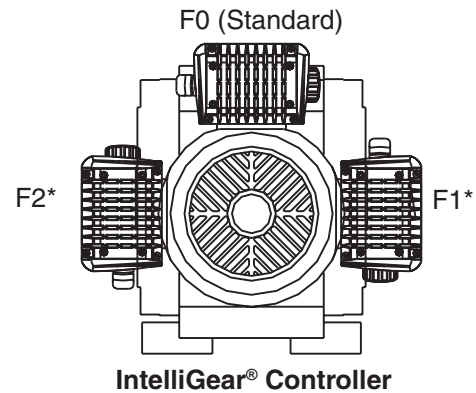

### Cable Entry

IntelliGear Cable Entry can be from either side of enclosure. If no option is specified, "A" will be supplied.

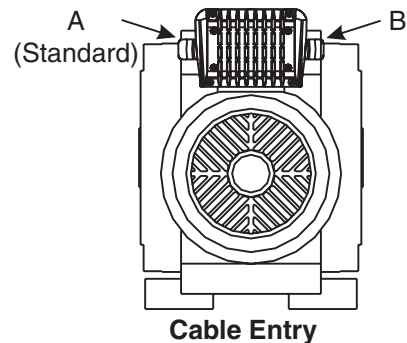

### FCR Brake Release Lever Positioning

Unit Type	Default Location	Optional Location(s)
OtN less IntelliGear	12 o'clock	3, 6, or 9 o'clock
OtN with IntelliGear	9 o'clock	3, 6, or 12 o'clock (but lever can not be in same position as the IntelliGear)

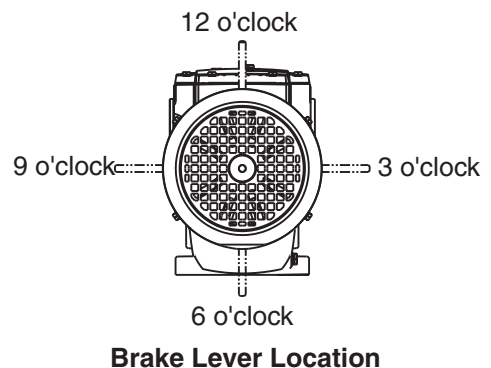

Modifications, Options and Accessories

**Inverter Duty Gearmotors**

Improvements in the motors for OtN gearmotors include an upgrade in the wire and varnish treatment used in all Allguard® non-explosionproof three phase motors. This makes the three phase gearmotor suitable for use with PWM inverters in many applications. A one year warranty will be extended for standard efficiency motors on constant torque applications over 3:1 range from 60-20 Hz. The same warranty is extended for high efficiency design motors on constant torque applications over 5:1 range from 60-12 Hz providing the following conditions are met:

- Motor is non-hazardous 3 phase > 48 frame
- Cable length to controller < 100 feet
- Line voltage is < 480 VAC
- Thermal protectors are not required

For all other conditions of operation (including 575 VAC) that exceed these parameters and all hazardous motor applications, select the inverter duty motor design under the motor Type required by the application. These designs include winding thermostats and will be covered by a three (3) year limited warranty of the motor as covered in the Standard Terms and Conditions, and full compliance with NEMA MG1 Part 31.

**Motor Modifications**

**M1 Brakes**

**Design**

These motor mounted brakes have a direct acting, spring set, electromagnetically released disc design. When power to the brake is interrupted, the brake will immediately set and hold. When power is restored to the brake then the brake will be released automatically.

**Brake Enclosures**

IP23 – suitable for indoors with relatively dry, clean and non-hazardous applications

IP55 – suitable for outdoor or indoor where gearmotor can be exposed to splashing liquids, dusts, and chemicals that are non-hazardous. Not suitable for washdown applications

Non-Hazardous Motor Types	Motor Frame Size(s)	
	56-180T	210T
S	IP23	N/A
T	IP55	IP23
IG	IP55	N/A

**Motor Modifications Continued**

**Operating Voltage**

Brakemotors for fixed frequency operation will be arranged for operating with motor power as standard. If another lower voltage like 115 VAC is to be used for the brake on a 3 phase motor, state this voltage at order entry

Brakes for inverter duty brakemotors require a separate fixed frequency AC power source for the brake, but interlocked with starting of the motor. The standard brake design for inverter duty gearmotors will be arranged for single phase 115/230 VAC.

**Mounting**

Brakes for OtN gearmotors are suitable for the mounting ordered for the gearmotor. The standard brake will have a manual release included. Refer to the table on B-18 for the manual release mounting options available on the FCR type IP 55 brake design.

**M2 Premium Efficiency Motors**

High efficiency motor design is a standard option for three phase motors on 56 frames and larger motors in types “T” and “C” to meet the energy legislation in Canada and most end user specifications.

Premium efficiency motors are also optional starting at 3 HP.

**M3 Washdown Duty Motors**

See GM1 under Gearmotor Modifications

**M4 Canopy Cap/Drip Cover**

A canopy cap can be supplied for protection from dripping liquids entering the fan end of a gearmotor. It is recommended but not standard when gearmotor mounting is ordered to be “V”

**M5 Frequency – 50 Hz**

Motors for operation at 50 Hz are available. Refer all 3 phase requirements for 50 Hz to motor code T53 (380V) or T54 (400/415V). The published output speed in catalogs are based on 60 Hz. When operating or selecting a 50 Hz gearmotor, catalog output speed must be reduced by 5/6 for a given ratio. The service factor must also be reduced by 5/6 if the HP is maintained.

For all other 50 Hz voltages, refer to application engineering.

## Modifications, Options and Accessories

### Motor Modifications Continued

#### M6 Voltage (3 phase only)

Standard voltages are listed in the table below. 200 VAC will be handled by 208-230/460V motors up to 10 HP. Refer all other voltages to the Pricing Group to confirm availability.

Frequency	3 Phase Voltages Thru 30 HP
60 Hz	200, 230, 460, 575
50 Hz	380, 400/415

#### M7 Motor Insulation

Emerson's 3 phase motors are built with a premium Class F insulation system for "T", "C" and "IG" types. All "S" and "X" type motors use a Class B insulation.

Tropical insulation treatment is available as a modification on any motor designs noted above

Class H insulation systems require production lead-times and are not available on explosions proof "X" designs.

#### M8 Space Heaters

Space heaters are recommended for gearmotors installed in very damp locations to prevent condensation from forming on the motor windings when the motor is not operating. Leads will be brought out to the standard motor conduit box. Space heater voltages (115, 230, and 460V) must be specified when an order is entered. This is available on motors > ¼ hp.

#### M9 Thermal Protection – Thermostats

This protection uses a bi-metallic disc thermostat embedded each phase of the motor winding and then connected by others into the holding circuit of the motor starter or VFD drive. The sensor is normally closed, and opens the control circuit to shut the motor down if the motor achieves over-temperature conditions based on the motor insulation class or design code. Thermostats give protection for running overloads, abnormally high ambient, voltage imbalance, high or low voltage, and ventilation failure. Thermostats do not give protection for locked rotor, starting overloads or single phasing.

Thermostats are standard in inverter duty motor designs (including IG) as well as explosionproof dual label motors type "X".

### Gear Modifications

#### G11 Corro-Duty

Corro-Duty treatment can be applied to a gearmotor or reducer when corrosive chemicals or unit will be operated outside in adverse environmental conditions. For gearmotors, the unit should start with specification of the Corro-Duty® type "C" motor design. Other special features of this treatment include:

- Normally closed breather design
- Corro-Duty exterior paint treatment (entire unit)
  - o Grey Option (default type)
    - 316 stainless steel paint (3 step)
    - Light grey semigloss finish
    - USDA and FDA approved
  - o White Option
    - Two step epoxy paint system
    - White gloss finish
    - USDA and FDA approved

For washdown application for gearmotors, refer to GM1 Washdown Duty Gearmotors and/or Washdown Duty Gearmotor PLUS.

#### G12a Foodgrade Synthetic Lubricant

When this modification is specified, the OtN oil sump is filled with the required volume of an FDA approved H1 rated synthetic lubricant for helical gearing (refer to page B-240).

#### G15 Export Boxing

Export boxing can be provided for "under-deck" transport. When the quantity of OtN gearmotors or reducers exceeds five (5) units, refer to international sales for most economical accommodations.

#### G16 Extra or Special Nameplate

Units can be provided with limited additional special information on the standard product nameplate. When required, an extra nameplate may be provided, stamped with custom markings.

## Modifications, Options and Accessories

### Gearmotor Modifications

#### GM1 Washdown Duty Gearmotors

This three phase gearmotor design combines special features of the gear and motor required for washdown duty. These include:

- Special treatment of motor interior and windings
- Drains at low point(s) of the motor frame
- Labyrinth seal at motor SE bracket/shaft extension
- Special “protected” breather for gearcase
- Corro-Duty exterior multi-application paint treatment (see Corro-Duty® Reducer for color options).

Motor types “W24” or “W5” are used to order this design based on motor voltage. This is available from 1/3 to 2 HP.

#### GM2 Washdown Duty Gearmotor PLUS

This three phase gearmotor design includes all the special features noted under GM1 above and the oil sump of the reducer will be filled before shipment with a FDA approved H1 rated synthetic lubricant for helical gearing (150). Volume of the oil will be dictated by the mounting position specified on the order.

Motor types “WP24” or “WP5” are used to order this design based on motor voltage. This is also available from 1/3 to 2 HP.

### Accessories

The following accessories can be ordered along with gearmotors and will be supplied loose for mounting by others

Description	Gear Frames	Part #
NPT Adapter (1/4" NPFT)	31 to 35	0436216
NPT Adapter (3/4" NPFT)	36 to 38	0436218
Bushing Guard Kit <sup>1</sup> (includes 2 guards to protect both sides)	32	XS9142
	33	XS9143
	34	XS9144
	35	XS9145
	36	XS9160
	37	XS9161
Oil Level View Port	31 to 35	0435936
	36 to 38	0435938
	38	PLA335F0002*

<sup>1</sup> These kits include all mounting hardware.

\* These kit contains only (1) Guard.

Mounting Accessories

Torque Reaction Arm

OtN Series

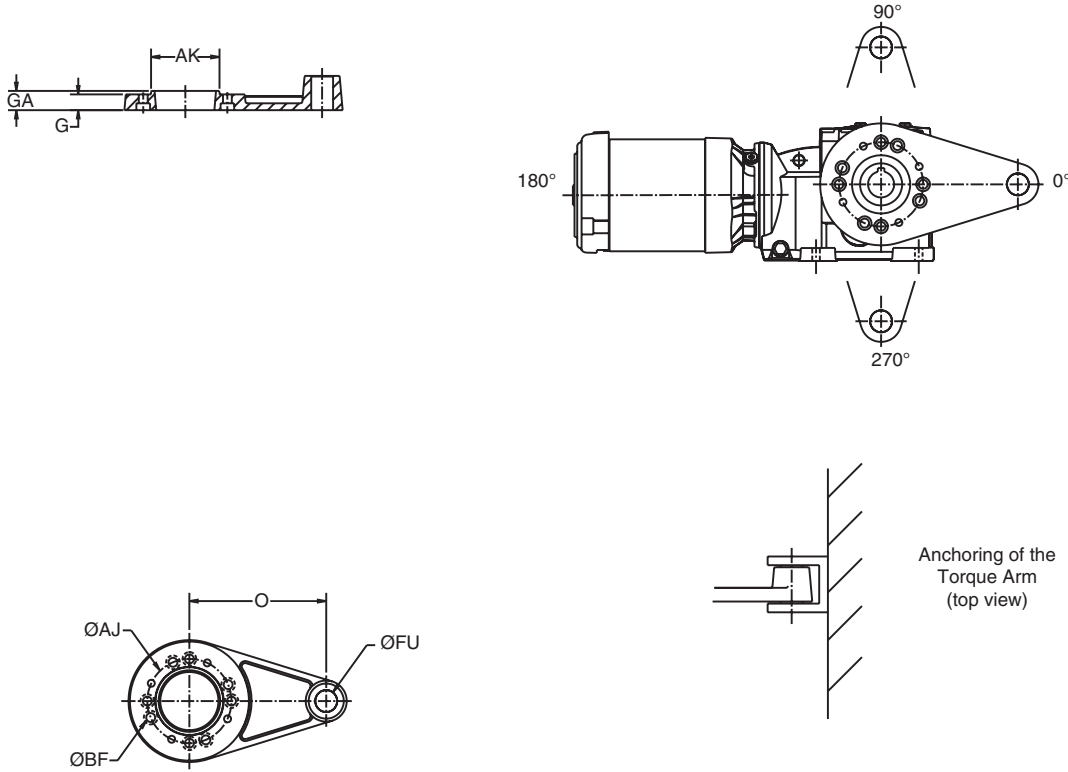

- Torque arm can be assembled in any of the three positions shown in the drawing above relative to the input (motor) when called out on the order.
- Torque arm can be affixed to either side of the 33C or 33B gear housing.
- If a torque arm is requested on an assembly order, it will be supplied loose for mounting by others.
- See page 23 for optional Torque Arm designs for frames 36 and 37.

Series 3000

OtN Frame	Part ID # Kit	G	O	AJ	AK	BF	FU	GA
31	ROC100KT001	-	5.118	3.74	3.246	.35	.394	.63
32	ROC200KT001	.63	5.118	3.94	3.150	.43	.394	.79
33	ROC300KT001	.91	7.874	4.84	3.937	.51	.630	1.10
34	ROC400KT001	-	9.842	5.98	5.118	.51	.630	.91
35	ROC500KT001	-	12.205	7.48	6.102	.67	.630	.908
36	ROC600KT001	0.79	13.78	9.06	5.905	.63	.940	.98
37	ROC700KT001	1.02	17.72	9.06	7.087	.87	.940	1.22
38	ROC800KT001	1.10	21.65	11.81	9.84	.87	2.20	1.34



**Torque Reaction Arm**

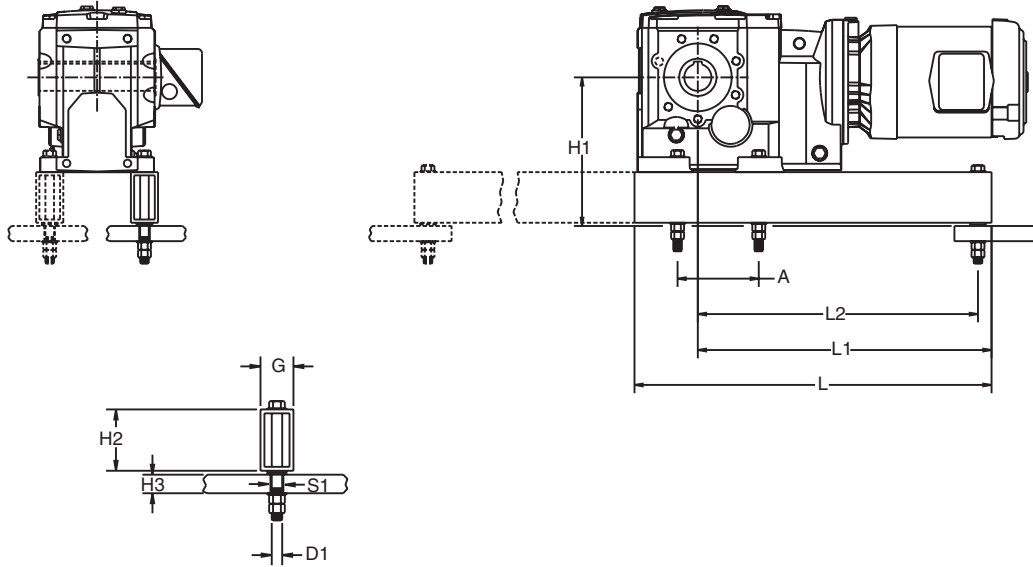

- Torque arm can be assembled with attachment point on the input side or 180° opposite this, as shown above.
- Torque arm can be attached onto feet on either side of the gear housing as you face opposite the input (motor).
- If the torque arm is requested on an assembly order, it will be supplied loose for mounting by others.

Gear Frame	Part Number	A	D1	G	H1	H2	H3 max.	L	L1	L2	S1 min.
36	0986479	13.98	.75	2.50	13.61	4.50	1.50	35.83	27.46	26.08	0.81
37	0986479	16.54	.75	2.50	14.59	4.50	1.50	35.83	26.18	24.80	0.81

## Screw Conveyor Drive Shafts<sup>2</sup>

Gear Frame	1 1/2" Dia. Shaft for 6" - 10" Dia. Screw	2" Dia. Shaft for 9" - 12" Dia. Screw	2 7/16" Dia. Shaft for 12" - 14" Dia. Screw	3" Dia. Shaft for 12" - 20" Dia. Screw	3 7/16" Dia. Shaft for 18" - 24" Dia. Screw
32	107DSP108__	107DSP200__	107DSP207__	107DSP300__	N/A
33	107DSP108__	107DSP200__	107DSP207__	107DSP300__	N/A
34	115DSP108__	115DSP200__	115DSP207__	115DSP300__	N/A
35	N/A	207DSP200__	207DSP207__	207DSP300__	207DSP307__
36	N/A	215DSP200__	215DSP207__	215DSP300__	215DSP307__
37	N/A	N/A	N/A	307DSP300__	307DSP307__
38	Not Available				

<sup>2</sup> Complete the shaft part number by adding shaft type as follows:

- Standard — 2 hole steel shaft = leave blank (example 107DSP108)
- Optional — 3 hole steel shaft = add -3 (example 107DSP108-3)
- Optional — 2 hole stainless steel shaft = add SS (example 107DSP108SS)
- Optional — 3 hole stainless steel shaft = add -3SS (example 107DSP108-3SS)

## Screw Conveyor Accessories

Gear Frame	Optional Seal Cartridges		Felt Seal <sup>1</sup>
	Waste Pack Kit	Packing Gland Kit	
32	107WWP	107PGP	FR200
33	107WWP	107PGP	FR200
34	115-203WWP	115-203PGP	FR210
35	207-407WWP	207-407PGP	FR308
36	207-407WWP	207-407PGP	FR308
37	207-407WWP	207-407PGP	FR308
38	Not Available		

<sup>1</sup> Felt seal can only be added to the waste pack seal cartridge kit.

### OtN Screw Conveyor Drives May Be Assembled in the Field

Required Components Include: OtN 73S or 37S gearmotor with screw conveyor adapter  
Screw conveyor drive shaft

Optional Components Include: Waste pack  
Packing gland  
Felt seal

Screw Conveyor Adapter  
(Included with type 73S or 37S gear unit)

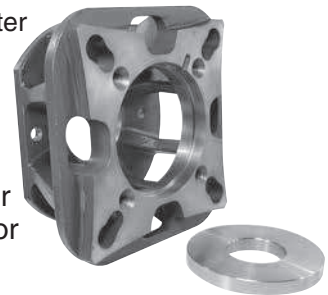

Waste Pack Kit



Packing Gland Kit



Screw Conveyor Drive Shaft Kit

## Screw Conveyor Thrust Ratings

Gear Frame	Maximum Thrust Rating (Lbs.)
32	2000
33	3000
34	4000
35	5000
36	6500
37	11000

Output tapered roller bearing standard - all sizes.

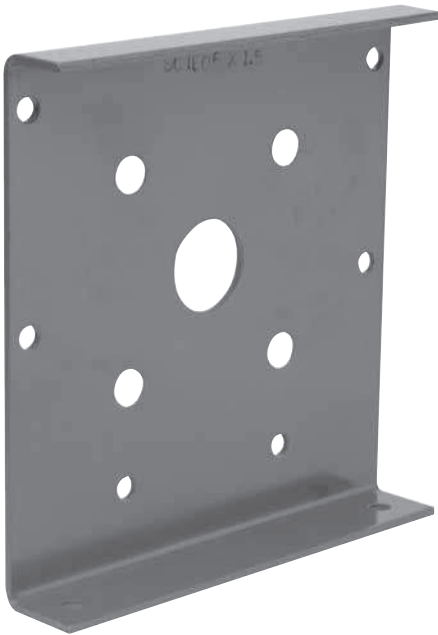

**Formed Hot Roll  
Plate Steel**

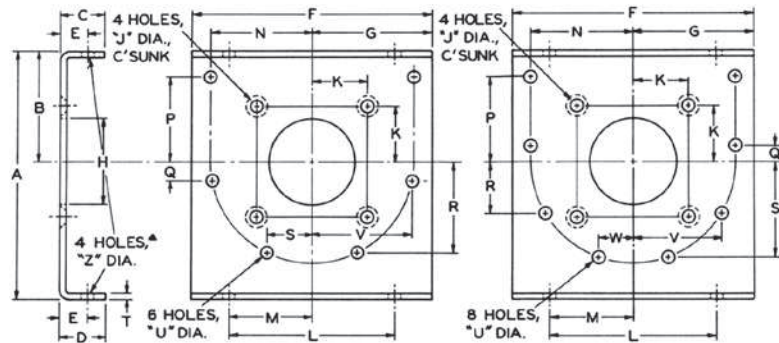

**FIG 1 - 6 HOLE TYPE**

**FIG 2 - 8 HOLE TYPE**

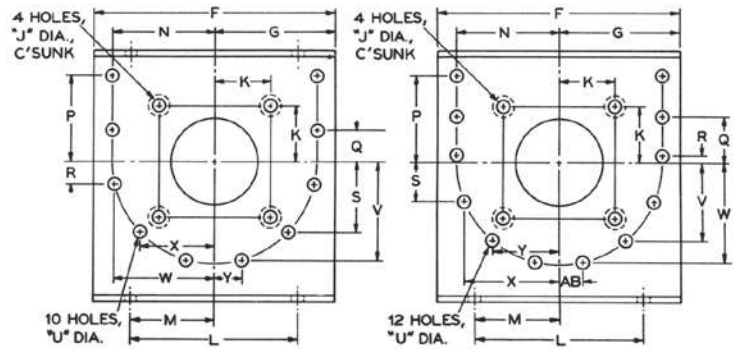

**FIG 3 - 10 HOLE TYPE**

**FIG 4 - 12 HOLE TYPE**

**Table No. 33**

**Specifications**

Part No.	Conveyor Screw Dia.	Drive Shaft Dia.	Fig.	Type	Dimensions											
					A	B	C	D	E	F	G	H	J	K	L	
SCTE06 x 1 1/2"	6"	1 1/2"	1	6-Hole	10 1/8"	4 1/2"	1 1/2"	1 3/4"	1"	9 3/4"	4 7/8"	1 3/4"	9/16"	2"	8 1/8"	
SCTE09 x 1 1/2"	9	1 1/2"	2	8-Hole	14	6 1/8"	1 5/8"	2 5/8"	1 1/2"	13 3/4"	6 7/8"	1 3/4"	9/16"	2"	9 3/8"	
SCTE09 x 2	9	2	2	8-Hole	14	6 1/8"	1 5/8"	2 5/8"	1 1/2"	13 3/4"	6 7/8"	2 1/4"	11/16"	2 9/16"	9 3/8"	
SCTE10 x 1 1/2"	10	1 1/2"	2	8-Hole	15 1/4"	6 3/8"	2 3/8"	2 7/8"	1 3/4"	14 3/4"	7 3/8"	3 3/4"	9/16"	2"	9 1/2"	
SCTE10 x 2	10	2	2	8-Hole	15 1/4"	6 3/8"	2 7/8"	2 7/8"	1 3/4"	14 3/4"	7 3/8"	2 1/4"	11/16"	2 9/16"	9 1/2"	
SCTE12 x 2	12	2	2	8-Hole	17 3/8"	7 3/4"	2	2 3/4"	1 5/8"	17 1/4"	8 5/8"	2 1/4"	11/16"	2 9/16"	12 1/4"	
SCTE12 x 2 7/16	12	2 7/16	2	8-Hole	17 3/8"	7 3/4"	2	2 3/4"	1 5/8"	17 1/4"	8 5/8"	2 11/16"	11/16"	2 13/16"	12 1/4"	
SCTE12 x 3	12	3	2	8-Hole	17 3/8"	7 3/4"	2	2 3/4"	1 5/8"	17 1/4"	8 5/8"	3 1/4"	13/16"	3	12 1/4"	
SCTE14 x 2 7/16	14	2 7/16	2	8-Hole	20 1/8"	9 1/4"	2	2 7/8"	1 5/8"	19 1/4"	9 5/8"	2 11/16"	11/16"	2 13/16"	13 1/2"	
SCTE14 x 3	14	3	2	8-Hole	20 1/8"	9 1/4"	2	2 7/8"	1 5/8"	19 1/4"	9 5/8"	3 1/4"	13/16"	3	13 1/2"	
SCTE16 x 3	16	3	2	8-Hole	22 5/8"	10 5/8"	2 1/2"	3 1/4"	2	21 1/4"	10 5/8"	3 1/4"	13/16"	3	14 7/8"	
SCTE18 x 3	18	3	3	10-Hole	25 1/2"	12 1/8"	2 1/2"	3 1/4"	2	24 1/4"	12 1/8"	3 1/4"	13/16"	3	16	
SCTE18 x 3 7/16	18	3 7/16	3	10-Hole	25 1/2"	12 1/8"	2 1/2"	3 1/4"	2	24 1/4"	12 1/8"	3 11/16"	13/16"	3 3/8"	16	
SCTE20 x 3	20	3	3	10-Hole	28 1/2"	13 1/2"	2 1/2"	3 3/4"	2 1/4"	26 1/4"	13 1/8"	3 1/4"	13/16"	3	19 1/4"	
SCTE20 x 3 7/16	20	3 7/16	3	10-Hole	28 1/2"	13 1/2"	2 1/2"	3 3/4"	2 1/4"	26 1/4"	13 1/8"	3 11/16"	13/16"	3 3/8"	19 1/4"	
SCTE24 x 3 7/16	24	3 7/16	4	12-Hole	34 5/8"	16 1/2"	2 1/2"	4 1/8"	2 1/2"	30 1/4"	15 1/8"	3 11/16"	13/16"	3 3/8"	20	

Part No.	Dimensions															Wt. Lbs.
	M	N	P	Q	R	S	T	U	V	W	X	Y	Z	AB		
SCTE06 x 1 1/2"	4 1/16"	4 7/16"	3 15/32"	5/8"	3 15/16"	2 1/32"	3/16"	7/16"	4 25/64"	-	-	-	7/16"	-	6.7	
SCTE09 x 1 1/2"	4 11/16"	6 1/4"	4 15/16"	13/16"	3 13/64"	5 45/64"	1/4"	7/16"	5 23/64"	2 9/16"	-	-	9/16"	-	17.8	
SCTE09 x 2	4 11/16"	6 1/4"	4 15/16"	13/16"	3 13/64"	5 45/64"	1/4"	7/16"	5 23/64"	2 9/16"	-	-	9/16"	-	17.7	
SCTE10 x 1 1/2"	4 3/4"	6 5/8"	4 1/8"	5/8"	3 3/8"	6 1/8"	1/4"	7/16"	5 45/64"	2 17/32"	-	-	9/16"	-	20.6	
SCTE10 x 2	4 3/4"	6 5/8"	4 1/8"	5/8"	3 3/8"	6 1/8"	1/4"	7/16"	5 45/64"	2 17/32"	-	-	9/16"	-	20.5	
SCTE12 x 2	6 1/8"	7 15/16"	6 1/4"	15/16"	4 7/64"	6 59/64"	5/16"	9/16"	6 51/64"	3 7/8"	-	-	11/16"	-	33.8	
SCTE12 x 2 7/16	6 1/8"	7 15/16"	6 1/4"	15/16"	4 7/64"	6 59/64"	5/16"	9/16"	6 51/64"	3 7/8"	-	-	11/16"	-	33.5	
SCTE12 x 3	6 1/8"	7 15/16"	6 1/4"	15/16"	4 7/64"	6 59/64"	5/16"	9/16"	6 51/64"	3 7/8"	-	-	11/16"	-	33.3	
SCTE14 x 2 7/16	6 3/4"	8 15/16"	6 23/32"	1 3/32"	4 11/16"	8 27/64"	5/16"	9/16"	7 39/64"	3	-	-	11/16"	-	42.4	
SCTE14 x 3	6 3/4"	8 15/16"	6 23/32"	1 3/32"	4 11/16"	8 27/64"	5/16"	9/16"	7 39/64"	3	-	-	11/16"	-	42.2	
SCTE16 x 3	7 7/16"	10	8	1 5/8"	4 57/64"	9 17/64"	5/16"	11/16"	8 23/32"	3 3/4"	-	-	11/16"	-	51.1	
SCTE18 x 3	8	11	9 1/2"	3 9/16"	2 25/64"	7 37/64"	5/16"	11/16"	10 19/32"	10 47/64"	7 63/64"	2 15/16"	11/16"	-	67.9	
SCTE18 x 3 7/16	8	11	9 1/2"	3 9/16"	2 25/64"	7 37/64"	5/16"	11/16"	10 19/32"	10 47/64"	7 63/64"	2 15/16"	11/16"	-	67.7	
SCTE20 x 3	9 5/8"	12 3/16"	10 23/32"	4 15/32"	2 13/64"	8 3/16"	3/8"	11/16"	11 23/32"	11 63/64"	9 1/32"	3 11/32"	13/16"	-	96.9	
SCTE20 x 3 7/16	9 5/8"	12 3/16"	10 23/32"	4 15/32"	2 13/64"	8 3/16"	3/8"	11/16"	11 23/32"	11 63/64"	9 1/32"	3 11/32"	13/16"	-	96.7	
SCTE24 x 3 7/16	10	14 1/4"	13 23/32"	7 19/32"	31/32"	5 33/64"	3/8"	11/16"	10 7/8"	13 55/64"	13 1/8"	9 7/32"	▲13/16"	3 5/16"	133.0	

Notes: Browning trough ends are drilled to fit CEMA Standard Troughs. The center holes are drilled to fit Browning screw conveyor drives.

▲ Figure 4 has 2 "Z" holes in bottom flange only; no holes in top flange.

**OtN Series**

Each Series 3000 OtN can be ordered with a Tapered Bushed Output. This “33B” mounting configuration will include the appropriate bushing kit unassembled when a bore is defined at order entry. The table below shows the various stocked bushing bores for each OtN frame that can be specified. Each bushing kit is supplied with bushing, hardware for mounting and a stabilizer ring. If bushings are required as a spare or bore changed in the field, refer to the OtN 3000 frame and select the required kit from below.



OtN Frame	Meas. Unit	Bushing Number	Bore <sup>1</sup>	Shaft Keyseat Required	Type	
31	Inch	105TBP100	1"	1/4 x 1/8 x 2 1/2	2	
		105TBP103	1 3/16"	1/4 x 1/8 x 2 1/2	2	
		105TBP104	1 1/4"	1/4 x 1/8 x 2 1/2	2	
		105TBP105	1 5/16"	5/16 x 5/32 x 2 1/2	2	
	Metric *	105TBP30MM	30 mm	8 x 3.5 x 65 (mm)	2	
32 & 33	Inch	107TBP105	1 5/16"	5/16 x 5/32 x 3 7/8	2	
		107TBP106	1 3/8"	5/16 x 5/32 x 3 7/8	2	
		107TBP107	1 7/16"	3/8 x 3/16 x 3 7/8	2	
		Metric *	107TBP30MM	30 mm	8 x 3.5 x 100 (mm)	2
		107TBP35MM	35 mm	10 x 4 x 100 (mm)	2	
33A	Inch	115TBP107	1 7/16	3/8 x 3/16 x 4 1/8	2	
		115TBP108	1 1/2	3/8 x 3/16 x 4 1/8	2	
		115TBP110	1 5/8	3/8 x 3/16 x 4 1/8	2	
		115TBP111	1 11/16	3/8 x 3/16 x 4 1/8	2	
		115TBP112	1 3/4	3/8 x 3/16 x 4 1/8	2	
		115TBP114	1 7/8	1/2 x 1/4 x 4 1/8	2	
			115TBP115	1 15/16	1/2 x 1/4 x 4 1/8	2
		Metric *	115TBP40MM	40 mm	12 x 4 x 105 (mm)	2
		115TBP45MM	45 mm	14 x 4.5 x 105 (mm)	2	
34	Inch	115TBP111	1 11/16	3/8 x 3/16 x 4 1/8	2	
		115TBP112	1 3/4	3/8 x 3/16 x 4 1/8	2	
		115TBP114	1 7/8	1/2 x 1/4 x 4 1/8	2	
		115TBP115	1 15/16	1/2 x 1/4 x 4 1/8	2	
		Metric *	115TBP45MM	45 mm	14 x 4.5 x 105 (mm)	2

<sup>1</sup> Bushing bore shown must be selected by customer based on complete application details.  
\* Metric bushings have metric bores and require metric keyseats as shown in mm.

OtN Frame	Meas. Unit	Bushing Number	Bore <sup>1</sup>	Shaft Keyseat Required	Type	
35	Inch	207TBP200	2	1/2 x 1/4 x 5 1/8	2	
		207TBP202	2 1/8	1/2 x 1/4 x 5 1/8	2	
		207TBP203	2 3/16	1/2 x 1/4 x 5 1/8	2	
		207TBP204	2 1/4	1/2 x 1/4 x 5 1/8	2	
		207TBP207	2 7/16	5/8 x 5/16 x 5 1/8	2	
		Metric *	207TBP50MM	50 mm	14 x 4.5 x 130 (mm)	2
		207TBP60MM	60 mm	18 x 5.5 x 130 (mm)	2	
36	Inch	215TBP207	2 7/16	5/8 X 5/16 X 5 5/8	2	
		215TBP208	2 1/2	5/8 X 5/16 X 5 5/8	2	
		215TBP211	2 11/16	5/8 X 5/16 X 5 5/8	2	
		215TBP215	2 15/16	3/4 X 3/8 X 5 5/8	2	
		Metric *	215TBP60MM	60 mm	18 x 5.5 x 140 (mm)	2
			215TBP70MM	70 mm	20 x 6 x 140 (mm)	2
37	Inch	307TBP214	2 7/8	3/4 x 3/8 x 6 3/4	2	
		307TBP215	2 15/16	3/4 x 3/8 x 6 3/4	2	
		307TBP300	3	3/4 x 3/8 x 6 3/4	2	
		307TBP306	3 3/8	7/8 x 7/16 x 6 3/4	2	
		307TBP307	3 7/16	7/8 x 7/16 x 6 3/4	2	
				307TBP75MM	75 mm	20 x 6 x 170 (mm)
		Metric *	307TPB80MM	80 mm	22 x 7 x 170 (mm)	2
			307TBP85MM	85 mm	22 x 7 x 170 (mm)	2
38	Inch	315TBP215	2 15/16	3/4 x 3/8 x 7 15/16	2	
		315TBP300	3	3/4 x 3/8 x 7 15/16	2	
		315TBP303	3 3/16	3/4 x 3/8 x 7 15/16	2	
		315TBP307	3 7/16	7/8 x 7/16 x 15/16	2	
		315TBP315	3 15/16	1 x 1/2 x 7 15/16	2	
				315TBP90MM	90mm	25 x 7 x 190 (mm)
		Metric*	315TBP90MM	90mm	25 x 7 x 190 (mm)	2

## AGMA Application Classifications

U: Uniform load    M: Moderate shock load    V: Heavy shock load

Application	Load	Class		Application	Load	Class		Application	Load	Class	
		Up to 10 hrs/day	Over 10 hrs/day			Up to 10 hrs/day	Over 10 hrs/day			Up to 10 hrs/day	Over 10 hrs/day
<b>Agitators</b>				<b>Bucket</b>				<b>Conveyors - Uniformly Loaded or Fed: Apron, Assembly, Belt, Bucket, Chain, Flight, Oven, Screw</b>	U	I	II
Paper Mills	M	II	II	Conveyors, Uniform	U	I	II				
Pure Liquids	U	I	II	Conveyors, Heavy Duty	M	II	II				
Liquids & Solids	M	II	II	Elevators Cont.	U	I	II				
Liquids - Variable Density	M	II	II	Elevators Uniform	U	I	II				
				Elevators, Heavy Duty	M	II	II				
<b>Apron Conveyors</b>				<b>Calenders</b>				<b>Conveyors - Heavy Duty Not Uniformly Fed: Apron, Assembly, Belt, Bucket, Chain, Flight, Oven, Screw</b>	M	II	II
Uniformly Loaded or Fed	U	I	II	Paper	U	-	II	Live Roll (Package)	U	I	II
Heavy Duty	M	II	II	Super (Paper)	U	-	II	Reciprocating, shaker	V	III	III
				Rubber	M	II	II				
<b>Apron Feeders</b>	M	II	II	Textile	M	II	II	<b>Cookers (Brewing and Distilling) (Food)</b>	U	I	II
				<b>Cane Knives</b>	M	II	II	<b>Cooling Tower Fans</b>			
<b>Assembly Conveyors</b>								Induced Draft	M	II	II
Uniformly Loaded or Fed	U	I	II	<b>Can Filling Machines</b>	U	I	II	Forced Draft	Refer to Application Engineering		
Heavy Duty	M	II	II					<b>Couch (Paper)</b>	M	-	II
				<b>Card Machines (Textile)</b>	M	II	II	<b>Cranes and Hoists</b>			
<b>Ball Mills</b>	V	III	III					Main Hoists			
				<b>Car Dumpers</b>	V	III	-	Heavy Duty	V	III	III
<b>Barking</b>								Medium Duty	M	II	II
Drums	V	-	III	<b>Car Pullers</b>	M	II	-	Reversing	V	II	II
Hydraulic Auxiliaries	V	-	III					Skip Hoists	M	II	II
Mechanical	V	-	III	<b>Cement Kilns</b>	Refer to Application Engineering			Trolley Drive	M	II	II
								Bridge Drive	M	II	II
<b>Barscreens (Sewage)</b>	U	I	II	<b>Centrifugal</b>				<b>Crushers</b>			
				Blowers, Compressors, Discharge Elevators or Pumps	U	I	II	Ore or Stone	V	III	III
<b>Batchers (Textile)</b>	M	II	II					<b>Cutters (Paper)</b>	V	-	III
				<b>Chain Conveyors</b>				<b>Cylinders (Paper)</b>	M	-	II
<b>Beaters and Pulpers (Paper)</b>	U	-	II	Uniformly Loaded or Fed	U	I	II	<b>Dewatering Screens (Sewage)</b>	M	II	II
				Heavy Duty	M	II	II				
<b>Belt Conveyors</b>				<b>Chemical Feeders (Sewage)</b>	U	I	II	<b>Disc Feeders</b>	U	I	II
Uniformly Loaded or Fed	U	I	II					<b>Distilling</b>	(See Brewing)		
Heavy Duty	M	II	II	<b>Clarifiers</b>	U	I	II				
								<b>Double Acting Pumps</b>			
<b>Belt Feeders</b>	M	II	II	<b>Classifiers</b>	M	II	II	2 or more Cylinders	M	II	II
								Single Cylinder	Refer to Application Engineering		
<b>Bending Rolls (Machine)</b>	M	II	II	<b>Clay Working Industry</b>				<b>Dough Mixer (Food)</b>	M	II	II
				Brick Press	V	III	III				
<b>Bleachers (Paper)</b>	M	-	II	Briquette Machine	V	III	III	<b>Draw Bench (Metal Mills)</b>			
				Clay Working Machinery	M	II	II	Carriage & Main Drive	V	III	III
<b>Blowers</b>				Pug Mill	M	II	II				
Centrifugal	U	I	II	<b>Collectors (Sewage)</b>	U	I	II	<b>Dredges</b>			
Lobe	M	II	II					Cable Reels	M	II	-
Vane	U	I	II	<b>Compressors</b>				Conveyors	M	II	II
				Centrifugal	U	I	II	Cutter Head Drives	V	III	III
<b>Bottling Machinery</b>	U	I	II	Lobe	M	II	II	Jig Drives	V	III	III
				Reciprocating,				Maneuvering Winches	M	II	-
<b>Brewing and Distilling</b>				Multi - Cylinder	M	II	II	Pumps	M	II	II
Bottling Machinery	U	I	II	Single - Cylinder	V	III	III	Screen Drives	V	III	III
Brew Kettles, Cont. Duty	U	-	II	<b>Concrete Mixers</b>				Stackers	M	II	II
Can Filling Machines	U	I	II	Continuous	M	II	II	Utility Winches	M	II	-
Cookers - Cont. Duty	U	-	II	Intermittent	U	I	-				
Mash Tubs - Cont. Duty	U	-	II	<b>Converting Machines (Paper)</b>	M	-	II				
Scale Hoppers - Frequent Starts	M	II	II								
<b>Brick Press (Clay Working)</b>	V	III	III								
<b>Briquetts Machines (Clay Working)</b>	V	III	III								

OtN Series



## AGMA Application Classifications

U: Uniform load      M: Moderate shock load      V: Heavy shock load

Application	Load		Class	Application	Load		Class	Application	Load		Class
	Up to	Over			Up to	Over			Up to	Over	
	10	10			10	10			10	10	
	hrs/day	hrs/day		hrs/day	hrs/day			hrs/day	hrs/day		
<b>Dryers (Paper)</b>	U	-	II	<b>Hammer Mills</b>	V	III	III	<b>Machine Tools</b>			
<b>Dryers and Coolers (Mills, Rotary)</b>	M	II	II	<b>Induced Draft Fans</b>	M	II	II	Auxiliary Drives	U	I	II
<b>Dyeing Machinery (Textile)</b>	M	II	II	<b>Jordans (Paper)</b>	U	-	II	Bending Rolls	M	II	II
<b>Elevators</b>				<b>Kilns (Mills, Rotary) Cement</b>	M	II	II	Main Drives	M	II	II
Bucket - Uniform Load	U	I	II	Refer to Application Engineering				Notching Press (Belted)	Refer to Application Engr.		
Bucket - Heavy Duty	M	II	II	<b>Laundry Washers and Tumblers</b>	M	II	II	Plate Planers	V	III	III
Bucket - Continuous	U	I	II	<b>Line Shafts</b>				Punch Press (Geared)	V	III	III
Centrifugal Discharge	U	I	II	Heavy Shock Load	V	III	III	Tapping Machines	V	III	III
Escalators	U	I	II	Moderate Shock Load	M	II	II	<b>Mangle (Textile)</b>	M	II	II
Freight	M	II	II	Uniform Load	U	I	II	<b>Mash Tubs (Brewing and Distilling)</b>	U	-	II
Gravity Discharge	U	I	II	<b>Live Roll Conveyors</b>				<b>Meat Grinder (Food)</b>	M	II	II
Man Lifts, Passenger	Refer to Application Engr.			Package	U	I	II	<b>Metal Mills</b>			
<b>Escalators</b>	U	I	II	<b>Lobe Blower or Compressors</b>	M	II	II	Draw Bench Carriages & Main Drives	V	III	III
<b>Fans</b>				<b>Log Hauls (Paper and Lumber)</b>	V	III	III	Forming Machines	V	III	III
Centrifugal	M	II	II	<b>Looms (Textile)</b>	M	II	II	Pinch, Dryer & Scrubber			
Cooling Towers				<b>Lumber Industry</b>				Rolls Reversing	Refer to Application Engineering		
Induced Draft	M	II	II	Barkers - Spindle Feed	V	II	III	Slitters	M	II	II
Forced Draft	Refer to Application Engr.			Barkers - Main Drive	V	III	III	Table Conveyors, Non-Reversing	M	II	III
Induced Draft	M	II	II	Carriage Drive	Refer to Application Engr.			Reversing	V	-	III
Large (Mine, etc.)	M	II	II	Conveyors				Wire Drawing & Flattening Machines	M	II	III
Large Industrial	M	II	II	Burner	V	II	III	Wire Winding Machines	M	II	II
Light (Small Diameter)	U	I	II	Main or Heavy Duty	V	II	III	<b>Mills, Rotary Type</b>			
<b>Feeders</b>				Main Log	V	III	III	Ball, Pebble, Rod	V	III	III
Apron, belt	M	II	II	Re-Saw Merry-Go-Round	V	II	III	Cement Kilns	Refer to Application Engineering		
Disc	U	I	II	Slab	V	III	III	Coolers, Dryers, Kilns	V	II	II
Reciprocating	V	III	III	Transfer	V	II	III	Tumbling Barrels	V	III	III
Screw	M	II	II	Chains - Floor	V	II	III	<b>Mixers (Also see Agitators)</b>			
<b>Felt</b>				Chains - Green	V	II	III	Concrete - Continuous	M	II	II
Stretchers (Paper)	U	-	II	Cut-Off Saws-Chain	V	II	III	Concrete - Intermittent	M	I	-
Whippers (Paper)	U	-	II	Cut-Off Saws-Drag	V	II	III	Constant Density	U	I	II
<b>Flight</b>				Debarking Drums	V	III	III	Variable Density	M	II	II
Conveyors, Uniform	U	I	II	Feeds - Edger	V	II	III	<b>Nappers (Textile)</b>	M	II	II
Conveyors, Heavy	M	II	II	Feeds - Gang	V	III	III	<b>Oil Industry</b>			
<b>Food Industry</b>				Feeds - Trimmer	V	II	III	Chillers	M	II	II
Beet Slicers	M	II	II	Log Deck	V	III	III	Oil Well Pumping	Refer to Application Engineering		
Bottling, Can Filling Mach.	U	I	II	Log Hauls - Incline, Well Type	V	III	III	Paraffin Filter Press	M	II	II
Cereal Cookers	U	I	II	Log Turning Devices	V	III	III	Rotary Kilns	M	II	II
Dough Mixers	M	II	II	Planner Feed	V	II	III	<b>Ore Crushers</b>	V	III	III
Meat Grinders	M	II	II	Planer Tilting Hoists	V	II	III	<b>Oven Conveyors</b>			
<b>Forming Machines (Metal Mills)</b>	V	III	III	Rolls - Live-Off Bearing				Uniform	U	I	II
<b>Generators (Not welding)</b>	U	I	II	Roll Cases	V	III	III	Heavy Duty	M	II	II
<b>Gravity Discharge Elevators</b>	U	I	II	Sorting Table	V	II	III				
<b>Grit Collectors (Sewage)</b>	U	I	II	Tipple Hoist	V	II	III				
				Transfers - Chain	V	II	III				
				Transfers - Craneway	V	II	III				
				Tray Drives	V	II	III				

## AGMA Application Classifications

U: Uniform load      M: Moderate shock load      V: Heavy shock load

Application	Load	Class	Application	Load	Class	Application	Load	Class
	Up to 10 hrs/day	Over 10 hrs/day		Up to 10 hrs/day	Over 10 hrs/day		Up to 10 hrs/day	Over 10 hrs/day
<b>Paper Mills</b>			<b>Rod Mills</b>	V	III	<b>Soapers (Textile)</b>	M	II
Agitator (Mixers)	M	II						II
Barker - Auxiliaries - Hyd.	V	-	<b>Rotary</b>			<b>Spinners (Textile)</b>	M	II
Barker, Mechanical	V	-	Pumps, Gear, Lobe, Vane	U	I			II
Barking Drum	V	-	Screens (Sand or Gravel)	V	II	<b>Steering Gears</b>	M	II
Beater & Pulper	M	-						II
Bleacher	M	-	<b>Rubber Industry</b>			<b>Stock Chests(Paper)</b>	U	-
Calenders	M	-	Mixer	V	III			II
Calenders - Super	M	-	Rubber Calender	M	II	<b>Stokers</b>	U	I
Converting Mach.-			Rubber Mill (2 or more)	M	II			II
Except Cutters - Platers	M	-	Sheeter	M	II	<b>Stone Crushers</b>	V	III
Conveyors	M	-	Tire Building Machines	Refer to Application Engr.				III
Couch	M	-	Tire, Tube Press Openers	Refer to Application		<b>Suction Rolls(Paper)</b>	U	-
Cutters, Platers	V	-	Engr.					II
Cylinders	U	-	Tubers & Strainers	M	II	<b>Table Conveyors</b>		
Dryers	U	-				<b>(Metal Mills) Non-Reversing</b>	V	II
Felt Stretchers	U	-	<b>Sand Mullers</b>	Refer to Application Engr.		Reversing	V	-
Felt Whippers	V	-						III
Jordans	M	-	<b>Screens</b>			<b>Tenter Frames</b>		
Log Haul	V	-	Air Washing	U	I	<b>(Textile)</b>	M	II
Presses	M	-	Rotary - Sand or Gravel	M	II			II
Pulp Machine Reels	M	-	Traveling Water Intake	U	I	<b>Textile Industry</b>		
Stock Chests	M	-				Batchers	M	II
Suction Rolls	M	-	<b>Screw Conveyors</b>			Calenders	M	II
Washers & Thickeners	M	-	Uniform	U	I	Card Machines	M	II
Winders	M	-	Heavy Duty or Feeder	M	II	Cloth Finishing Mach. (Cal-		
						enders, Dryers, Pads,		
<b>Passenger Elevators</b>	Refer to Application Engr.		<b>Scum Breakers</b>			Tenters, Washers)	M	II
			<b>(Sewage)</b>	M	II	Dry Cans	M	II
<b>Pebble Mills</b>	V	III				Dyeing Machinery	M	II
			<b>Sewage Disposal</b>			Knitting Machinery	Refer to Application Engr.	
<b>Plate Planers</b>	V	III	Aerators	Refer to Application Engr.		Looms, Mangles, Nappers	M	II
			Bar Screens	U	I	Range Drives	Refer to Application Engr.	
<b>Presses (Paper)</b>	V	-	Chemical Feeders	U	I	Soapers, Spinners	M	II
			Collectors	U	I	Tenter Frames	M	II
<b>Proportioning Pumps</b>	M	II	Dewatering Screens	M	II	Winders	M	II
			Grit Collectors	U	I	Yarn Preparatory Mach.		
<b>Pub Mills (Clay)</b>	M	II	Scum Breakers	M	II	(Cards, Spinners, Slashers)	M	II
			Slow or Rapid Mixers	M	II			
<b>Pullers (Barge Haul)</b>	V	III	Sludge Collectors	U	I	<b>Thickeners (Sewage)</b>	M	II
			Thickeners	M	II			II
<b>Pulp Machine Reels</b>	U	-	Vacuum Filters	M	II	<b>Tumbling Barrels</b>	V	III
								III
<b>Pumps</b>			<b>Shaker Conveyors</b>	V	III	<b>Vacuum Filters</b>		
Centrifugal	U	I				<b>(sewage)</b>	M	II
Proportioning	M	II	<b>Sheeters (Rubber)</b>	M	II			II
Reciprocating						<b>Vane Blowers</b>	U	I
Single Act., 3 or more cyl.	M	II	<b>Single Acting Pump</b>					II
Double Act., 2 or more cyl.	M	II	1 or 2 Cylinders	Refer to Application Engr.		<b>Winches (Dredges)</b>	M	II
Single Act., 1 or 2 cyl.	Refer to Application Engr.		3 or more Cylinders	M	II			-
Rotary: Gear, Lobe, Vane	U	I				<b>Winders</b>		
			<b>Skip Hoist</b>	M	II	<b>(Paper)</b>	U	-
<b>Punch Press</b>						<b>(Textile)</b>	M	II
<b>(Gear Driven)</b>	V	III	<b>Slab Pushers</b>	M	II			II
						<b>Windlass</b>	M	II
<b>Reciprocating</b>			<b>Slitters (Metal)</b>	M	II			II
Conveyors, Feeders	V	III				<b>Wire</b>		
			<b>Sludge Collectors</b>			Drawing Machines	M	II
<b>Reciprocating Compressors</b>			<b>(Sewage)</b>	U	I	Winding Machines	M	II
Multi-Cylinder	M	II						III
Single cylinder	V	III						II

OtN Series

Applications not listed in this table, or where the user has data indicating the severity of this usage to be greater than average, should be referred to Application Engineering.

## 1/3 HP

General Specifications: Totally enclosed, 60 hertz, 40°C ambient, continuous duty.

OtN Series

Output RPM	AGMA Class	Service Factor	Output Torque in - lbs	OHL $\Delta$ lb	Nominal Ratio	Frame Size Gear	Motor	Std. Motor Types $\diamond$
472	I, II, III	3+	42	1825	3.55	3242	56	T,C,S,X,IG
374	I, II, III	3+	53	1955	4.5	3242	56	T,C,S,X,IG
343	I, II, III	3+	58	1294	5	3132	56	T,C,S,X,IG
313	I, II, III	3+	64	2062	5.6	3242	56	T,C,S,X,IG
272	I, II, III	3+	73	1294	6.3	3132	56	T,C,S,X,IG
242	I, II, III	3+	82	1294	7.1	3132	56	T,C,S,X,IG
230	I, II, III	3+	87	1294	8	3132	56	T,C,S,X,IG
203	I, II, III	3+	98	1294	9	3132	56	T,C,S,X,IG
180	I, II, III	3+	111	1294	10	3132	56	T,C,S,X,IG
159	I, II, III	3+	126	1294	11.2	3132	56	T,C,S,X,IG
140	I, II, III	3+	143	1294	12.5	3132	56	T,C,S,X,IG
122	I, II, III	3+	163	1294	14	3132	56	T,C,S,X,IG
109	I, II, III	3+	184	1294	16	3132	56	T,C,S,X,IG
102	I, II, III	3+	195	1294	18	3132	56	T,C,S,X,IG
86	I, II, III	3+	232	1294	20	3132	56	T,C,S,X,IG
81	I, II, III	3+	245	1294	22.4	3132	56	T,C,S,X,IG
71	I, II, III	3+	281	1294	25	3132	56	T,C,S,X,IG
64	I, II, III	3+	313	1294	28	3132	56	T,C,S,X,IG
57	I, II, III	3+	350	1294	31.5	3132	56	T,C,S,X,IG
49	I, II, III	3+	406	1294	35.5	3132	56	T,C,S,X,IG
45	I, II, III	3+	446	1294	40	3132	56	T,C,S,X,IG
39	I, II, III	3+	511	1294	45	3132	56	T,C,S,X,IG
35	I, II, III	3+	564	1294	50	3132	56	T,C,S,X,IG
32	I, II, III	3+	605	1490	56	3243	56	T,C,S,X,IG
27	I, II, III	3+	719	1490	63	3243	56	T,C,S,X,IG
26	I, II, III	3+	761	1490	71	3243	56	T,C,S,X,IG
23	I, II, III	3+	869	1490	80	3243	56	T,C,S,X,IG
20	I, II, III	3+	970	1490	90	3243	56	T,C,S,X,IG
18	I, II, III	3+	1087	1490	100	3243	56	T,C,S,X,IG
15	I, II, III	3+	1264	1490	112	3243	56	T,C,S,X,IG
14	I, II, III	2.9	1387	1490	125	3243	56	T,C,S,X,IG
12	I, II, III	2.5	1588	1490	140	3243	56	T,C,S,X,IG
11	I, II, III	2.3	1745	1490	160	3243	56	T,C,S,X,IG
10.1	I, II, III	3+	1869	2090	180	3365	56	T,C,S,X,IG
9.8	I, II, III	2.1	1912	1490	180	3245	56	T,C,S,X <sup>o</sup> ,IG
8.9	I, II, III	3+	2106	2090	200	3365	56	T,C,S,X,IG
8.9	I, II	1.9	2116	1490	200	3245	56	T,C,S,X <sup>o</sup> ,IG
8.5	I, II	1.8	2224	1490	224	3245	56	T,C,S,X <sup>o</sup> ,IG
7.9	I, II, III	3+	2385	2090	224	3365	56	T,C,S,X,IG
7.1	I, II	1.5	2643	1490	250	3245	56	T,C,S,X <sup>o</sup> ,IG

$\diamond$  **Standard Motor Types** (see page B-15 for product codes)

T TEFC, three phase, 208-230/460 or 575 volts

S TEFC, single phase, 115/230 volts

C Corro-Duty<sup>®</sup>, three phase, 230/460 or 575 volts

X<sup>o</sup> Explosionproof, CL1 group D, three phase, 230/460 or 575 volts

X Explosionproof, CI 1 group D, CI 2 groups F&G, three phase, 230/460 or 575 volts

IG IntelliGear<sup>®</sup> variable speed for 1-ph/115V, 1-ph/230V, 3-ph/230V, or 3-ph/460V power supplies, NEMA 4/12

$\Delta$  Overhung load rating is at shaft midpoint.

## 1/3 HP (Continued)

General Specifications: Totally enclosed, 60 hertz, 40°C ambient, continuous duty.

Output RPM	AGMA Class	Service Factor	Output Torque in - lbs	OHL Δ lb	Nominal Ratio	Frame Size Gear	Motor	Std. Motor Types ◇
6.9	I, II, III	2.6	2707	2090	250	3365	56	T,C,S,X,IG
6.7	I, II	1.4	2825	1490	280	3245	56	T,C,S,X°,IG
6.1	I, II, III	2.3	3094	2090	280	3365	56	T,C,S,X,IG
5.9	I	1.2	3169	1490	315	3245	56	T,C,S,X°,IG
5.4	I, II, III	2.0	3491	2090	315	3365	56	T,C,S,X,IG
5.1	I	1.1	3685	1490	355	3245	56	T,C,S,X°,IG
5.1	I, II	1.9	3706	2090	355	3365	56	T,C,S,X,IG
4.7	I	1.0	3975	1490	400	3245	56	T,C,S,X°,IG
4.5	I, II, III	3+	4147	2875	400	3475	56	T,C,S,X,IG
4.3	I, II	1.6	4405	2090	400	3365	56	T,C,S,X,IG
4.0	I, II	1.5	4662	2090	450	3365	56	T,C,S,X,IG
4.0	I, II, III	3+	4695	2875	450	3475	56	T,C,S,X,IG
3.6	I, II, III	2.8	5178	2875	500	3475	56	T,C,S,X,IG
3.5	I	1.3	5329	2090	500	3365	56	T,C,S,X,IG
3.2	I, II, III	2.4	5887	2875	560	3475	56	T,C,S,X,IG
3.2	I	1.2	5941	2090	560	3365	56	T,C,S,X,IG
2.8	I	1.1	6661	2090	630	3365	56	T,C,S,X,IG
2.8	I, II, III	2.1	6725	2875	630	3475	56	T,C,S,X,IG
2.5	I, II	1.9	7594	2875	710	3475	56	T,C,S,X,IG
2.4	I, II, III	2.9	7961	4100	800	3585	56	T,C,S,X,IG
2.3	I, II	1.8	8057	2875	800	3475	56	T,C,S,X,IG
2.0	I, II, III	2.5	9303	4100	900	3585	56	T,C,S,X,IG
2.0	I, II	1.5	9572	2875	900	3475	56	T,C,S,X,IG
1.9	I, II	1.4	10120	2875	1000	3475	56	T,C,S,X,IG
1.8	I, II, III	2.2	10485	4100	1000	3585	56	T,C,S,X,IG
1.6	I, II, III	2.0	11871	4100	1120	3585	56	T,C,S,X,IG
1.5	I	1.1	12730	2875	1120	3475	56	T,C,S,X,IG
1.4	I, II	1.7	13482	4100	1250	3585	56	T,C,S,X,IG
1.3	I, II	1.7	14170	4100	1400	3585	56	T,C,S,X,IG
1.3	I	1.0	14557	2875	1250	3475	56	T,C,S,X,IG
1.2	I, II	1.5	16104	4100	1600	3585	56	T,C,S,X,IG
1	I	1.3	18403	4100	1800	3585	56	T,C,S,X,IG
0.91	I	1.1	20766	4100	2000	3585	56	T,C,S,X,IG
0.85	I	1.1	22034	4100	2240	3585	56	T,C,S,X,IG

OtN Series

◇ **Standard Motor Types** (see page B-15 for product codes)

T TEFC, three phase, 208-230/460 or 575 volts

S TEFC, single phase, 115/230 volts

C Corro-Duty®, three phase, 230/460 or 575 volts

X° Explosionproof, CL1 group D, three phase, 230/460 or 575 volts

X Explosionproof, Cl 1 group D, Cl 2 groups F&G, three phase, 230/460 or 575 volts

IG IntelliGear® variable speed for 1-ph/115V, 1-ph/230V, 3-ph/230V, or 3-ph/460V power supplies, NEMA 4/12

Δ Overhung load rating is at shaft midpoint.

## 1/2 HP

OtN Series

General Specifications: Totally enclosed, 60 hertz, 40°C ambient, continuous duty.

Output RPM	AGMA Class	Service Factor	Output Torque in - lbs	OHL $\Delta$ lb	Nominal Ratio	Frame Size Gear	Motor	Std. Motor Types $\diamond$
472	I, II, III	3+	64	1825	3.55	3242	56	T,C,S,X,IG
374	I, II, III	3+	81	1955	4.5	3242	56	T,C,S,X,IG
343	I, II, III	3+	88	1294	5	3132	56	T,C,S,X,IG
313	I, II, III	3+	97	2062	5.6	3242	56	T,C,S,X,IG
272	I, II, III	3+	111	1294	6.3	3132	56	T,C,S,X,IG
242	I, II, III	3+	125	1294	7.1	3132	56	T,C,S,X,IG
230	I, II, III	3+	132	1294	8	3132	56	T,C,S,X,IG
203	I, II, III	3+	149	1294	9	3132	56	T,C,S,X,IG
180	I, II, III	3+	168	1294	10	3132	56	T,C,S,X,IG
159	I, II, III	3+	190	1294	11.2	3132	56	T,C,S,X,IG
140	I, II, III	3+	216	1294	12.5	3132	56	T,C,S,X,IG
122	I, II, III	3+	247	1294	14	3132	56	T,C,S,X,IG
109	I, II, III	3+	278	1294	16	3132	56	T,C,S,X,IG
102	I, II, III	3+	296	1294	18	3132	56	T,C,S,X,IG
86	I, II, III	3+	351	1294	20	3132	56	T,C,S,X,IG
81	I, II, III	3+	372	1294	22.4	3132	56	T,C,S,X,IG
71	I, II, III	3+	425	1294	25	3132	56	T,C,S,X,IG
64	I, II, III	3+	474	1294	28	3132	56	T,C,S,X,IG
57	I, II, III	3+	531	1294	31.5	3132	56	T,C,S,X,IG
49	I, II, III	3+	615	1294	35.5	3132	56	T,C,S,X,IG
45	I, II, III	3+	676	1294	40	3132	56	T,C,S,X,IG
39	I, II, III	2.0	774	1294	45	3132	56	T,C,S,X,IG
35	I, II, III	2.0	854	1294	50	3132	56	T,C,S,X,IG
32	I, II, III	3+	917	1490	56	3243	56	T,C,S,X,IG
27	I, II, III	3+	1090	1490	63	3243	56	T,C,S,X,IG
26	I, II, III	3+	1152	1490	71	3243	56	T,C,S,X,IG
23	I, II, III	3+	1317	1490	80	3243	56	T,C,S,X,IG
20	I, II, III	2.7	1469	1490	90	3243	56	T,C,S,X,IG
18	I, II, III	2.4	1647	1490	100	3243	56	T,C,S,X,IG
15	I, II, III	2.1	1915	1490	112	3243	56	T,C,S,X,IG
14	I, II	1.9	2102	1490	125	3243	56	T,C,S,X,IG
14	I, II, III	3+	2119	2090	125	3363	56	T,C,S,X,IG
13	I, II, III	3+	2322	2090	140	3363	56	T,C,S,X,IG
12	I, II	1.7	2407	1490	140	3243	56	T,C,S,X,IG
11	I, II	1.5	2644	1490	160	3243	56	T,C,S,X,IG
11	I, II, III	2.6	2712	2090	160	3363	56	T,C,S,X,IG
10	I, II, III	2.5	2832	2090	180	3365	56	T,C,S,X,IG
10	I, II	1.4	2897	1490	180	3245	56	T,C,S,X°,IG
7.9	I, II, III	2.0	3614	2090	224	3365	56	T,C,S,X,IG
7.1	I	1.0	4004	1490	250	3245	56	T,C,S,X°,IG

$\diamond$  **Standard Motor Types** (see page B-15 for product codes)

T TEFC, three phase, 208-230/460 or 575 volts

S TEFC, single phase, 115/230 volts

C Corro-Duty®, three phase, 230/460 or 575 volts

X° Explosionproof, CL1 group D, three phase, 230/460 or 575 volts

X Explosionproof, CI 1 group D, CI 2 groups F&G, three phase, 230/460 or 575 volts

IG IntelliGear® variable speed for 1-ph/115V, 1-ph/230V, 3-ph/230V, or 3-ph/460V power supplies, NEMA 4/12

$\Delta$  Overhung load rating is at shaft midpoint.



## 1/2 HP (Continued)

General Specifications: Totally enclosed, 60 hertz, 40°C ambient, continuous duty.

Output RPM	AGMA Class	Service Factor	Output Torque in - lbs	OHL Δ lb	Nominal Ratio	Frame Size Gear	Motor	Std. Motor Types ◇
7.0	I, II, III	3+	4069	2875	250	3475	56	T,C,S,X,IG
6.9	I, II	1.7	4102	2090	250	3365	56	T,C,S,X,IG
6.1	I, II, III	3+	4655	2875	280	3475	56	T,C,S,X,IG
6.1	I, II	1.5	4688	2090	280	3365	56	T,C,S,X,IG
5.4	I, II, III	2.7	5241	2875	315	3475	56	T,C,S,X,IG
5.4	I	1.3	5290	2090	315	3365	56	T,C,S,X,IG
5.1	I, II, III	2.6	5567	2875	355	3475	56	T,C,S,X,IG
5.1	I	1.3	5616	2090	355	3365	56	T,C,S,X,IG
4.5	I, II, III	2.3	6283	2875	400	3475	56	T,C,S,X,IG
4.3	I	1.1	6674	2090	400	3365	56	T,C,S,X,IG
4.2	I, II, III	3+	6723	4100	450	3585	56	T,C,S,X,IG
4.0	I	1.0	7064	2090	450	3365	56	T,C,S,X,IG
4.0	I, II, III	2.0	7113	2875	450	3475	56	T,C,S,X,IG
3.6	I, II	1.8	7846	2875	500	3475	56	T,C,S,X,IG
3.6	I, II, III	2.9	7976	4100	500	3585	56	T,C,S,X,IG
3.4	I, II, III	2.7	8432	4100	560	3585	56	T,C,S,X,IG
3.2	I, II	1.6	8920	2875	560	3475	56	T,C,S,X,IG
3.0	I, II, III	2.4	9636	4100	630	3585	56	T,C,S,X,IG
2.8	I, II	1.4	10190	2875	630	3475	56	T,C,S,X,IG
2.6	I, II, III	2.1	10759	4100	710	3585	56	T,C,S,X,IG
2.5	I	1.2	11508	2875	710	3475	56	T,C,S,X,IG
2.4	I, II	1.9	12061	4100	800	3585	56	T,C,S,X,IG
2.3	I	1.2	12208	2875	800	3475	56	T,C,S,X,IG
2.0	I, II	1.7	14096	4100	900	3585	56	T,C,S,X,IG
2.0	I	1.0	14503	2875	900	3475	56	T,C,S,X,IG
1.9	I, II, III	2.2	14420	13249	900	3695	56	T,C,S,X,IG
1.8	I, II	1.5	15887	4100	1000	3585	56	T,C,S,X,IG
1.6	I	1.3	17986	4100	1120	3585	56	T,C,S,X,IG
1.6	II, III	2.3	17482	13249	1120	3695	56	T,C,S,X,IG
1.5	I, II, III	3+	18816	18242	1120	3705	56	T,C,S,X,IG
1.4	I	1.1	20428	4100	1250	3585	56	T,C,S,X,IG
1.4	II	1.9	20411	13249	1250	3695	56	T,C,S,X,IG
1.3	II, III	3+	21128	18242	1250	3705	56	T,C,S,X,IG
1.3	I	1.1	21470	4100	1400	3585	56	T,C,S,X,IG
1.2	I	1.0	24400	4100	1600	3585	56	T,C,S,X,IG
1.2	III	3+	23878	18242	1400	3705	56	T,C,S,X,IG
1.2	II	1.7	24481	13249	1400	3695	56	T,C,S,X,IG
1.1	I, II	1.6	26157	13249	1600	3695	56	T,C,S,X,IG
1.1	III	2.9	26434	18242	1600	3705	56	T,C,S,X,IG
1.0	I, II	1.4	29673	13249	1800	3695	56	T,C,S,X,IG

◇ **Standard Motor Types** (see page B-15 for product codes)

T TEFC, three phase, 208-230/460 or 575 volts

S TEFC, single phase, 115/230 volts

C Corro-Duty®, three phase, 230/460 or 575 volts

X° Explosionproof, CL1 group D, three phase, 230/460 or 575 volts

X Explosionproof, Cl 1 group D, Cl 2 groups F&G, three phase, 230/460 or 575 volts

IG IntelliGear® variable speed for 1-ph/115V, 1-ph/230V, 3-ph/230V, or 3-ph/460V power supplies, NEMA 4/12

Δ Overhung load rating is at shaft midpoint.

## 1/2 HP (Continued)

General Specifications: Totally enclosed, 60 hertz, 40°C ambient, continuous duty.

OtN Series

Output RPM	AGMA Class	Service Factor	Output Torque in - lbs	OHL $\Delta$ lb	Nominal Ratio	Frame Size Gear	Motor	Std. Motor Types $\diamond$
0.95	III	2.5	30129	18242	1800	3705	56	T,C,S,X,IG
0.86	I	1.2	32961	13249	2000	3695	56	T,C,S,X,IG
0.82	II, III	2.6	34735	18242	2000	3705	56	T,C,S,X,IG
0.81	III	3.4	35084	21873	2240	3825	56	T,C,S,X,IG
0.77	II, III	2.0	37112	18242	2240	3705	56	T,C,S,X,IG
0.76	I	1.1	37453	13249	2240	3695	56	T,C,S,X,IG
0.70	II, III	2.9	40970	21873	2500	3825	56	T,C,S,X,IG
0.68	I	1.0	41669	13249	2500	3695	56	T,C,S,X,IG
0.68	II	1.8	42125	18242	2500	3705	56	T,C,S,X,IG
0.64	II, III	2.7	44791	21873	2800	3825	56	T,C,S,X,IG
0.61	I, II	1.6	46780	18242	2800	3705	56	T,C,S,X,IG
0.54	I, II	1.4	53144	18242	3150	3705	56	T,C,S,X,IG
0.54	III	2.3	52502	21873	3150	3825	56	T,C,S,X,IG
0.49	II, III	2.1	57954	21873	3550	3825	56	T,C,S,X,IG
0.48	I	1.3	59118	18242	3550	3705	56	T,C,S,X,IG
0.45	II	1.9	63549	21873	4000	3825	56	T,C,S,X,IG
0.43	I	1.1	66508	18242	4000	3705	56	T,C,S,X,IG
0.38	II	1.6	74209	21873	4500	3825	56	T,C,S,X,IG
0.37	I	1.0	77967	18242	4500	3705	56	T,C,S,X,IG
0.35	II	1.5	80705	21873	5000	3826	56	T,C,S,X,IG
0.30	I	1.3	93026	21873	5600	3826	56	T,C,S,X,IG
0.28	I	1.2	99405	21873	6300	3826	56	T,C,S,X,IG
0.25	I	1.1	112816	21873	7100	3826	56	T,C,S,X,IG
0.22		0.95	125300	21873	8000	3826	56	T,C,S,X,IG

$\diamond$  **Standard Motor Types** (see page B-15 for product codes)

T TEFC, three phase, 208-230/460 or 575 volts

S TEFC, single phase, 115/230 volts

C Corro-Duty<sup>®</sup>, three phase, 230/460 or 575 volts

X<sup>°</sup> Explosionproof, CL1 group D, three phase, 230/460 or 575 volts

X Explosionproof, CI 1 group D, CI 2 groups F&G, three phase, 230/460 or 575 volts

IG IntelliGear<sup>®</sup> variable speed for 1-ph/115V, 1-ph/230V, 3-ph/230V, or 3-ph/460V power supplies, NEMA 4/12

$\Delta$  Overhung load rating is at shaft midpoint.

## 3/4 HP

General Specifications: Totally enclosed, 60 hertz, 40°C ambient, continuous duty.

Output RPM	AGMA Class	Service Factor	Output Torque in - lbs	OHL Δ lb	Nominal Ratio	Frame Size Gear	Motor	Std. Motor Types ◇
472	I, II, III	3+	96	1825	3.55	3242	56	T,C,S,X,IG
374	I, II, III	3+	121	1955	4.5	3242	56	T,C,S,X,IG
343	I, II, III	3+	132	1294	5	3132	56	T,C,S,X,IG
313	I, II, III	3+	145	2063	5.6	3242	56	T,C,S,X,IG
272	I, II, III	3+	167	1294	6.3	3132	56	T,C,S,X,IG
242	I, II, III	3+	187	1294	7.1	3132	56	T,C,S,X,IG
230	I, II, III	3+	198	1294	8	3132	56	T,C,S,X,IG
203	I, II, III	3+	224	1294	9	3132	56	T,C,S,X,IG
180	I, II, III	3+	252	1294	10	3132	56	T,C,S,X,IG
159	I, II, III	3+	285	1294	11.2	3132	56	T,C,S,X,IG
140	I, II, III	3+	324	1294	12.5	3132	56	T,C,S,X,IG
122	I, II, III	3+	371	1294	14	3132	56	T,C,S,X,IG
109	I, II, III	3+	417	1294	16	3132	56	T,C,S,X,IG
102	I, II, III	3+	443	1294	18	3132	56	T,C,S,X,IG
86	I, II, III	3+	526	1294	20	3132	56	T,C,S,X,IG
81	I, II, III	3.0	558	1294	22.4	3132	56	T,C,S,X,IG
71	I, II, III	2.7	638	1294	25	3132	56	T,C,S,X,IG
64	I, II, III	2.5	710	1294	28	3132	56	T,C,S,X,IG
57	I, II, III	2.3	796	1294	31.5	3132	56	T,C,S,X,IG
49	I, II, III	2.1	923	1294	35.5	3132	56	T,C,S,X,IG
45	I, II	1.9	1014	1294	40	3132	56	T,C,S,X,IG
44	III	3+	1004	1490	40	3243	56	T,C,S,X,IG
39	I,	1.3	1162	1294	45	3132	56	T,C,S,X,IG
39	II, III	3+	1149	1490	45	3243	56	T,C,S,X,IG
35	I,	1.3	1281	1294	50	3132	56	T,C,S,X,IG
34	II, III	3+	1297	1490	50	3243	56	T,C,S,X,IG
32	I, II, III	2.8	1375	1490	56	3243	56	T,C,S,X,IG
27	I, II, III	2.4	1635	1490	63	3243	56	T,C,S,X,IG
26	I, II, III	2.3	1729	1490	71	3243	56	T,C,S,X,IG
23	I, II, III	2.0	1975	1490	80	3243	56	T,C,S,X,IG
20	I, II, III	3+	2179	2090	90	3363	56	T,C,S,X,IG
20	I, II	1.8	2204	1490	90	3243	56	T,C,S,X,IG
18	I, II, III	2.9	2451	2090	100	3363	56	T,C,S,X,IG
18	I, II	1.6	2471	1490	100	3243	56	T,C,S,X,IG
15	I, II	1.4	2873	1490	112	3243	56	T,C,S,X,IG
15	I, II, III	2.5	2873	2090	112	3363	56	T,C,S,X,IG

OtN Series

◇ Standard Motor Types (see page B-15 for product codes)

T TEFC, three phase, 208-230/460 or 575 volts

S TEFC, single phase, 115/230 volts

C Corro-Duty®, three phase, 230/460 or 575 volts

X Explosionproof, Cl 1 group D, Cl 2 groups F&G, three phase, 230/460 or 575 volts

IG IntelliGear® variable speed for 1-ph/115V, 1-ph/230V, 3-ph/230V, or 3-ph/460V power supplies, NEMA 4/12

Δ Overhung load rating is at shaft midpoint.

## 3/4 HP (Continued)

General Specifications: Totally enclosed, 60 hertz, 40°C ambient, continuous duty.

OtN Series

Output RPM	AGMA Class	Service Factor	Output Torque in - lbs	OHL $\Delta$ lb	Nominal Ratio	Frame Size Gear	Motor	Std. Motor Types $\diamond$
14	I	1.3	3152	1490	125	3243	56	T,C,S,X,IG
14	I, II, III	2.2	3178	2090	125	3363	56	T,C,S,X,IG
13	I, II, III	2.1	3483	2090	140	3363	56	T,C,S,X,IG
12	I	1.1	3610	1490	140	3243	56	T,C,S,X,IG
11	I, II, III	3+	3915	2875	160	3473	56	T,C,S,X,IG
11	I	\$1.0	3966	1490	160	3243	56	T,C,S,X,IG
11	I, II	1.8	4068	2090	160	3363	56	T,C,S,X,IG
10.2	I, II, III	3+	4200	2875	180	3475	56	T,C,S,X,IG
10.1	I, II	1.7	4248	2090	180	3365	56	T,C,S,X,IG
9.0	I, II, III	3+	4737	2875	200	3475	56	T,C,S,X,IG
8.9	I, II	1.5	4786	2090	200	3365	56	T,C,S,X,IG
8.0	I, II, III	2.6	5372	2875	224	3475	56	T,C,S,X,IG
7.9	I	1.3	5420	2090	224	3365	56	T,C,S,X,IG
7.0	I, II, III	2.3	6104	2875	250	3475	56	T,C,S,X,IG
6.9	I	1.1	6153	2090	250	3365	56	T,C,S,X,IG
6.1	I, II, III	2.0	6983	2875	280	3475	56	T,C,S,X,IG
6.1	I	1.0	7032	2090	280	3365	56	T,C,S,X,IG
5.8	I, II, III	3+	7374	4100	315	3585	56	T,C,S,X,IG
5.4	I, II	1.8	7862	2875	315	3475	56	T,C,S,X,IG
5.1	I, II	1.7	8350	2875	355	3475	56	T,C,S,X,IG
5.1	I, II, III	2.7	8423	4100	355	3585	56	T,C,S,X,IG
4.5	I, II	1.5	9425	2875	400	3475	56	T,C,S,X,IG
4.5	I, II, III	2.4	9498	4100	400	3585	56	T,C,S,X,IG
4.2	I, II, III	2.3	10084	4100	450	3585	56	T,C,S,X,IG
4.0	I	1.3	10670	2875	450	3475	56	T,C,S,X,IG
3.6	I	1.2	11768	2875	500	3475	56	T,C,S,X,IG
3.6	I, II	1.9	11964	4100	500	3585	56	T,C,S,X,IG
3.4	I, II	1.8	12647	4100	560	3585	56	T,C,S,X,IG
3.2	I	1.1	13380	2875	560	3475	56	T,C,S,X,IG
3.0	I, II	1.6	14454	4100	630	3585	56	T,C,S,X,IG
2.9	III	2.7	14771	13249	630	3695	56	T,C,S,X,IG
2.6	III	2.4	16432	13249	710	3695	56	T,C,S,X,IG
2.6	I, II	1.4	16139	4100	710	3585	56	T,C,S,X,IG
2.4	I	1.3	18092	4100	800	3585	56	T,C,S,X,IG
2.3	II, III	2.2	18483	13249	800	3695	56	T,C,S,X,IG
2.0	I	1.1	21144	4100	900	3585	56	T,C,S,X,IG
2.0	II	1.8	21657	13249	900	3695	56	T,C,S,X,IG
1.8	III	3+	23317	18242	900	3705	56	T,C,S,X,IG
1.8	I	1.0	23830	4100	1000	3585	56	T,C,S,X,IG
1.8	II	1.7	23903	13249	1000	3695	56	T,C,S,X,IG

$\diamond$  **Standard Motor Types** (see page B-15 for product codes)

T TEFC, three phase, 208-230/460 or 575 volts

S TEFC, single phase, 115/230 volts

C Corro-Duty<sup>®</sup>, three phase, 230/460 or 575 volts

X Explosionproof, CI 1 group D, CI 2 groups F&G, three phase, 230/460 or 575 volts

IG IntelliGear<sup>®</sup> variable speed for 1-ph/115V, 1-ph/230V, 3-ph/230V, or 3-ph/460V power supplies, NEMA 4/12

$\Delta$  Overhung load rating is at shaft midpoint.

## 3/4 HP (Continued)

General Specifications: Totally enclosed, 60 hertz, 40°C ambient, continuous duty.

Output RPM	AGMA Class	Service Factor	Output Torque in - lbs	OHL $\Delta$ lb	Nominal Ratio	Frame Size Gear	Motor	Std. Motor Types $\diamond$
1.7	III	2.8	25734	18242	1000	3705	56	T,C,S,X,IG
1.6	I, II	1.5	26222	13249	1120	3695	56	T,C,S,X,IG
1.5	III	2.6	28224	18242	1120	3705	56	T,C,S,X,IG
1.4	I	1.3	30617	13249	1250	3695	56	T,C,S,X,IG
1.3	II, III	2.4	31691	18242	1250	3705	56	T,C,S,X,IG
1.2	II, III	2.1	35818	18242	1400	3705	56	T,C,S,X,IG
1.2	I	1.1	36721	13249	1400	3695	56	T,C,S,X,IG
1.1	I	1.0	39236	13249	1600	3695	56	T,C,S,X,IG
1.1	II	1.9	39651	18242	1600	3705	56	T,C,S,X,IG
1		0.92	44510	13249	1800	3695	56	T,C,S,X,IG
1.0	III	2.7	43478	21873	1800	3825	56	T,C,S,X,IG
0.95	I, II	1.7	45193	18242	1800	3705	56	T,C,S,X,IG
0.89	III	2.5	47993	21873	2000	3825	56	T,C,S,X,IG
0.82	I, II	1.4	52103	18242	2000	3705	56	T,C,S,X,IG
0.81	III	2.3	52626	21873	2240	3825	56	T,C,S,X,IG
0.77	I, II	1.4	55667	18242	2240	3705	56	T,C,S,X,IG
0.70	II	1.9	61455	21873	2500	3825	56	T,C,S,X,IG
0.68	I, II	1.2	63187	18242	2500	3705	56	T,C,S,X,IG
0.64	II	1.8	67186	21873	2800	3825	56	T,C,S,X,IG
0.61	I, II	1.1	70170	18242	2800	3705	56	T,C,S,X,IG
0.54		0.95	79717	18242	3150	3705	56	T,C,S,X,IG
0.54	I, II	1.5	78753	21873	3150	3825	56	T,C,S,X,IG
0.49	I, II	1.4	86931	21873	3550	3825	56	T,C,S,X,IG
0.45	I	1.3	95324	21873	4000	3825	56	T,C,S,X,IG
0.38	I	1.1	111314	21873	4500	3825	56	T,C,S,X,IG
0.35		0.99	121058	21873	5000	3826	56	T,C,S,X,IG

OtN Series

$\diamond$  **Standard Motor Types** (see page B-15 for product codes)

T TEFC, three phase, 208-230/460 or 575 volts

S TEFC, single phase, 115/230 volts

C Corro-Duty<sup>®</sup>, three phase, 230/460 or 575 volts

X Explosionproof, CI 1 group D, CI 2 groups F&G, three phase, 230/460 or 575 volts

IG IntelliGear<sup>®</sup> variable speed for 1-ph/115V, 1-ph/230V, 3-ph/230V, or 3-ph/460V power supplies, NEMA 4/12

$\Delta$  Overhung load rating is at shaft midpoint.

## 1 HP

General Specifications: Totally enclosed, 60 hertz, 40°C ambient, continuous duty.

OtN Series

Output RPM	AGMA Class	Service Factor	Output Torque in - lbs	OHL $\Delta$ lb	Nominal Ratio	Frame Size Gear	Motor	Std. Motor Types $\diamond$
472	I, II, III	3+	128	1808	3.55	3242	143T	T,C,S,X,IG
374	I, II, III	3+	162	1933	4.5	3242	143T	T,C,S,X,IG
343	I, II, III	3+	176	1294	5	3132	143T	T,C,S,X,IG
313	I, II, III	3+	194	2036	5.6	3242	143T	T,C,S,X,IG
272	I, II, III	3+	222	1294	6.3	3132	143T	T,C,S,X,IG
242	I, II, III	3+	250	1294	7.1	3132	143T	T,C,S,X,IG
230	I, II, III	3+	263	1294	8	3132	143T	T,C,S,X,IG
203	I, II, III	3+	298	1294	9	3132	143T	T,C,S,X,IG
180	I, II, III	3+	336	1294	10	3132	143T	T,C,S,X,IG
159	I, II, III	3+	380	1294	11.2	3132	143T	T,C,S,X,IG
140	I, II, III	3+	432	1294	12.5	3132	143T	T,C,S,X,IG
122	I, II, III	2.9	494	1294	14	3132	143T	T,C,S,X,IG
109	I, II, III	2.7	557	1294	16	3132	143T	T,C,S,X,IG
102	I, II, III	2.6	591	1294	18	3132	143T	T,C,S,X,IG
86	I, II, III	2.3	702	1294	20	3132	143T	T,C,S,X,IG
81	I, II, III	2.2	743	1294	22.4	3132	143T	T,C,S,X,IG
71	I, II, III	2.0	851	1294	25	3132	143T	T,C,S,X,IG
64	I, II	1.9	947	1294	28	3132	143T	T,C,S,X,IG
64	III	3+	925	1428	28	3243	143T	T,C,S,X,IG
57	I, II	1.7	1061	1294	31.5	3132	143T	T,C,S,X,IG
57	III	3+	1044	1471	31.5	3243	143T	T,C,S,X,IG
50	III	3+	1178	1490	35.5	3243	143T	T,C,S,X,IG
49	I, II	1.6	1231	1294	35.5	3132	143T	T,C,S,X,IG
45	I, II	1.5	1352	1294	40	3132	143T	T,C,S,X,IG
44	III	2.9	1339	1490	40	3243	143T	T,C,S,X,IG
39	I	1.0	1549	1294	45	3132	143T	T,C,S,X,IG
39	II, III	2.6	1532	1490	45	3243	143T	T,C,S,X,IG
35	I	1.0	1708	1294	50	3132	143T	T,C,S,X,IG
34	II, III	2.3	1729	1490	50	3243	143T	T,C,S,X,IG
32	I, II, III	2.1	1834	1490	56	3243	143T	T,C,S,X,IG
29	I, II, III	3+	2068	2090	63	3363	143T	T,C,S,X,IG
27	I, II	1.8	2180	1490	63	3243	143T	T,C,S,X,IG
26	I, II, III	3+	2298	2090	71	3363	143T	T,C,S,X,IG
26	I, II	1.7	2305	1490	71	3243	143T	T,C,S,X,IG
23	I, II, III	2.7	2610	2090	80	3363	143T	T,C,S,X,IG
23	I, II	1.5	2634	1490	80	3243	143T	T,C,S,X,IG
20	I, II, III	2.4	2905	2090	90	3363	143T	T,C,S,X,IG
20	I	1.3	2939	1490	90	3243	143T	T,C,S,X,IG
18	I, II, III	2.2	3268	2090	100	3363	143T	T,C,S,X,IG
18	I	1.2	3295	1490	100	3243	143T	T,C,S,X,IG

$\diamond$  **Standard Motor Types** (see page B-15 for product codes)  
 T TEFC, three phase, 208-230/460 or 575 volts  
 S TEFC, single phase, 115/230 volts  
 C Corro-Duty®, three phase, 230/460 or 575 volts  
 X Explosionproof, CI 1 group D, CI 2 groups F&G, three phase, 230/460 or 575 volts  
 IG IntelliGear® variable speed for 1-ph/230V, 3-ph/230V, or 3-ph/460V power supplies, NEMA 4/12

$\Delta$  Overhung load rating is at shaft midpoint.



## 1 HP (Continued)

General Specifications: Totally enclosed, 60 hertz, 40°C ambient, continuous duty.

Output RPM	AGMA Class	Service Factor	Output Torque in - lbs	OHL Δ lb	Nominal Ratio	Frame Size		Std. Motor Types ◇
						Gear	Motor	
16	I, II, III	3+	3661	2875	112	3473	143T	T,C,S,X,IG
15	I	1.0	3830	1490	112	3243	143T	T,C,S,X,IG
15	I, II	1.9	3830	2090	112	3363	143T	T,C,S,X,IG
14	I, II, III	3+	4203	2875	125	3473	143T	T,C,S,X,IG
14	I, II	1.7	4237	2090	125	3363	143T	T,C,S,X,IG
13	I, II	1.5	4644	2090	140	3363	143T	T,C,S,X,IG
13	I, II, III	3+	4712	2875	140	3473	143T	T,C,S,X,IG
11	I, II, III	2.7	5220	2875	160	3473	143T	T,C,S,X,IG
11	I	1.3	5424	2090	160	3363	143T	T,C,S,X,IG
10.2	I, II, III	2.5	5599	2875	180	3475	143T	T,C,S,X,IG
10.1	I	1.2	5664	2090	180	3365	143T	T,C,S,X,IG
9.0	I, II, III	2.2	6316	2875	200	3475	143T	T,C,S,X,IG
8.9	I	1.1	6381	2090	200	3365	143T	T,C,S,X,IG
8.0	I, II, III	2.0	7162	2875	224	3475	143T	T,C,S,X,IG
7.9	I	1.0	7227	2090	224	3365	143T	T,C,S,X,IG
7.4	I, II, III	3+	7650	4100	250	3585	143T	T,C,S,X,IG
7.0	I, II	1.7	8139	2875	250	3475	143T	T,C,S,X,IG
6.6	I, II, III	2.6	8627	4100	280	3585	143T	T,C,S,X,IG
6.1	I, II	1.5	9310	2875	280	3475	143T	T,C,S,X,IG
5.8	I, II, III	2.3	9831	4100	315	3585	143T	T,C,S,X,IG
5.4	I	1.3	10482	2875	315	3475	143T	T,C,S,X,IG
5.1	I	1.3	11133	2875	355	3475	143T	T,C,S,X,IG
5.1	I, II, III	2.0	11231	4100	355	3585	143T	T,C,S,X,IG
4.5	I	1.1	12566	2875	400	3475	143T	T,C,S,X,IG
4.5	I, II	1.8	12664	4100	400	3585	143T	T,C,S,X,IG
4.2	I, II	1.7	13445	4100	450	3585	143T	T,C,S,X,IG
4.1	III	2.9	13738	13249	450	3695	143T	T,C,S,X,IG
4.0	I	1.0	14226	2875	450	3475	143T	T,C,S,X,IG
3.7	II, III	2.6	15593	13249	500	3695	143T	T,C,S,X,IG
3.6	I, II	1.4	15951	4100	500	3585	143T	T,C,S,X,IG
3.4	I, II	1.4	16863	4100	560	3585	143T	T,C,S,X,IG
3.3	III	2.3	17319	13249	560	3695	143T	T,C,S,X,IG
3.0	I	1.2	19272	4100	630	3585	143T	T,C,S,X,IG
2.9	II, III	2.0	19695	13249	630	3695	143T	T,C,S,X,IG
2.6	II	1.8	21909	13249	710	3695	143T	T,C,S,X,IG
2.6	I	1.1	21518	4100	710	3585	143T	T,C,S,X,IG
2.4	III	3+	23569	18242	710	3705	143T	T,C,S,X,IG
2.3	I, II	1.6	24643	13249	800	3695	143T	T,C,S,X,IG
2.1	III	2.8	26532	18242	800	3705	143T	T,C,S,X,IG

◇ Standard Motor Types (see page B-15 for product codes)

T TEFC, three phase, 208-230/460 or 575 volts

S TEFC, single phase, 115/230 volts

C Corro-Duty®, three phase, 230/460 or 575 volts

X Explosionproof, Cl 1 group D, Cl 2 groups F&G, three phase, 230/460 or 575 volts

IG IntelliGear® variable speed for 1-ph/230V, 3-ph/230V, or 3-ph/460V power supplies, NEMA 4/12

Δ Overhung load rating is at shaft midpoint.

## 1 HP (Continued)

General Specifications: Totally enclosed, 60 hertz, 40°C ambient, continuous duty.

OtN Series

Output RPM	AGMA Class	Service Factor	Output Torque in - lbs	OHL Δ lb	Nominal Ratio	Frame Size Gear	Motor	Std. Motor Types ◇
2.0	I, II	1.4	28875	13249	900	3695	143T	T,C,S,X,IG
1.8	III	2.4	31089	18242	900	3705	143T	T,C,S,X,IG
1.8	I	1.2	31870	13249	1000	3695	143T	T,C,S,X,IG
1.7	II, III	2.1	34312	18242	1000	3705	143T	T,C,S,X,IG
1.6	I	1.1	34963	13249	1120	3695	143T	T,C,S,X,IG
1.5	II	1.9	37632	18242	1120	3705	143T	T,C,S,X,IG
1.4	I	1	40823	13249	1250	3695	143T	T,C,S,X,IG
1.4	III	3.0	39512	21873	1250	3825	143T	T,C,S,X,IG
1.3	I, II	1.8	42255	18242	1250	3705	143T	T,C,S,X,IG
1.3	III	2.7	43961	21873	1400	3825	143T	T,C,S,X,IG
1.2	I, II	1.6	47757	18242	1400	3705	143T	T,C,S,X,IG
1.2	III	2.4	49456	21873	1600	3825	143T	T,C,S,X,IG
1.1	I, II	1.4	52868	18242	1600	3705	143T	T,C,S,X,IG
1.0	III	2.1	57971	21873	1800	3825	143T	T,C,S,X,IG
0.95	I	1.3	60258	18242	1800	3705	143T	T,C,S,X,IG
0.89	III	1.9	63991	21873	2000	3825	143T	T,C,S,X,IG
0.82	I	1.1	69470	18242	2000	3705	143T	T,C,S,X,IG
0.81	III	1.7	70169	21873	2240	3825	143T	T,C,S,X,IG
0.77	I	1	74223	18242	2240	3705	143T	T,C,S,X,IG
0.70	II	1.5	81940	21873	2500	3825	143T	T,C,S,X,IG
0.64	I	1.3	89581	21873	2800	3825	143T	T,C,S,X,IG
0.54	I	1.1	105004	21873	3150	3825	143T	T,C,S,X,IG
0.49	I	1.0	115908	21873	3550	3825	143T	T,C,S,X,IG
0.45		0.94	127098	21873	4000	3825	143T	T,C,S,X,IG

◇ **Standard Motor Types** (see page B-15 for product codes)

T TEFC, three phase, 208-230/460 or 575 volts

S TEFC, single phase, 115/230 volts

C Corro-Duty®, three phase, 230/460 or 575 volts

X Explosionproof, CI 1 group D, CI 2 groups F&G, three phase, 230/460 or 575 volts

IG IntelliGear® variable speed for 1-ph/230V, 3-ph/230V, or 3-ph/460V power supplies, NEMA 4/12

Δ Overhung load rating is at shaft midpoint.

## 1 1/2 HP

General Specifications: Totally enclosed, 60 hertz, 40°C ambient, continuous duty.

Output RPM	AGMA Class	Service Factor	Output Torque in - lbs	OHL Δ lb	Nominal Ratio	Frame Size Gear	Motor	Std. Motor Types ◇
472	I, II, III	3+	192	2071	3.55	3242	145T	T,C,S,X,IG
374	I, II, III	3+	243	2071	4.5	3242	145T	T,C,S,X,IG
343	I, II, III	3+	264	1294	5	3132	145T	T,C,S,X,IG
313	I, II, III	3+	290	2071	5.6	3242	145T	T,C,S,X,IG
272	I, II, III	3.2	333	1294	6.3	3132	145T	T,C,S,X,IG
242	I, II, III	3.0	375	1294	7.1	3132	145T	T,C,S,X,IG
230	I, II, III	2.9	395	1294	8	3132	145T	T,C,S,X,IG
203	I, II, III	2.7	447	1294	9	3132	145T	T,C,S,X,IG
180	I, II, III	2.5	504	1294	10	3132	145T	T,C,S,X,IG
159	I, II, III	2.3	570	1294	11.2	3132	145T	T,C,S,X,IG
140	I, II, III	2.1	648	1294	12.5	3132	145T	T,C,S,X,IG
124	III	3+	731	1146	14	3242	145T	T,C,S,X,IG
122	I, II	1.9	742	1294	14	3132	145T	T,C,S,X,IG
109	I, II	1.8	835	1294	16	3132	145T	T,C,S,X,IG
112	III	3+	809	1189	16	3242	145T	T,C,S,X,IG
102	I, II	1.7	887	1294	18	3132	145T	T,C,S,X,IG
99	III	3+	918	1198	18	3242	145T	T,C,S,X,IG
89	III	3.1	1022	1258	20	3242	145T	T,C,S,X,IG
86	I, II	1.5	1053	1294	20	3132	145T	T,C,S,X,IG
81	I, II	1.5	1115	1294	22.4	3132	145T	T,C,S,X,IG
79	III	3+	1151	1291	22.4	3242	145T	T,C,S,X,IG
71	I, II	1.4	1276	1294	25	3132	145T	T,C,S,X,IG
67	III	2.4	1348	1306	25	3242	145T	T,C,S,X,IG
64	I	1.3	1421	1294	28	3132	145T	T,C,S,X,IG
61	II, III	2.1	1488	1340	28	3242	145T	T,C,S,X,IG
57	I	1.2	1592	1294	31.5	3132	145T	T,C,S,X,IG
56	II, III	2.0	1634	2071	31.5	3242	145T	T,C,S,X,IG
50	III	2.2	1769	1403	35.5	3243	145T	T,C,S,X,IG
49	I	1.1	1846	1294	35.5	3132	145T	T,C,S,X,IG
48	II	1.7	1908	2071	35.5	3242	145T	T,C,S,X,IG
46	I, II, III	3+	1947	2090	40	3363	145T	T,C,S,X,IG
44	I, II	1.9	2008	1433	40	3243	145T	T,C,S,X,IG
40	I, II, III	3+	2222	2090	45	3363	145T	T,C,S,X,IG
39	I, II	1.7	2298	1461	45	3243	145T	T,C,S,X,IG
35	I, II, III	2.7	2557	2090	50	3363	145T	T,C,S,X,IG
34	I, II	1.5	2593	1483	50	3243	145T	T,C,S,X,IG
33	I, II, III	2.6	2735	2090	56	3363	145T	T,C,S,X,IG
32	I, II	1.4	2751	1490	56	3243	145T	T,C,S,X,IG
29	I, II, III	2.3	3102	2090	63	3363	145T	T,C,S,X,IG
27	I	1.2	3269	1490	63	3243	145T	T,C,S,X,IG

◇ **Standard Motor Types** (see page B-15 for product codes)

T TEFC, three phase, 208-230/460 or 575 volts

S TEFC, single phase, 115/230 volts (Note that the frame is 145TY for single phase).

C Corro-Duty®, three phase, 230/460 or 575 volts

X Explosionproof, CI 1 group D, CI 2 groups F&G, three phase, 230/460 or 575 volts

IG IntelliGear® variable speed for 1-ph/230V, 3-ph/230V, or 3-ph/460V power supplies, NEMA 4/12

Δ Overhung load rating is at shaft midpoint.

## 1 1/2 HP (Continued)

General Specifications: Totally enclosed, 60 hertz, 40°C ambient, continuous duty.

OtN Series

Output RPM	AGMA Class	Service Factor	Output Torque in - lbs	OHL Δ lb	Nominal Ratio	Frame Size Gear	Motor	Std. Motor Types ◇
26	I, II, III	2.0	3447	2090	71	3363	145T	T,C,S,X,IG
26	I	1.1	3457	1490	71	3243	145T	T,C,S,X,IG
23	I, II	1.8	3915	2090	80	3363	145T	T,C,S,X,IG
23	I, II, III	3+	3940	2875	80	3473	145T	T,C,S,X,IG
23	I	1.0	3951	1490	80	3243	145T	T,C,S,X,IG
20	I, II	1.6	4357	2090	90	3363	145T	T,C,S,X,IG
20	I, II, III	3+	4459	2875	90	3473	145T	T,C,S,X,IG
18	I, II, III	2.9	4851	2875	100	3473	145T	T,C,S,X,IG
18	I, II	1.4	4901	2090	100	3363	145T	T,C,S,X,IG
16	I, II, III	2.6	5491	2875	112	3473	145T	T,C,S,X,IG
15	I	1.2	5745	2090	112	3363	145T	T,C,S,X,IG
14	I, II, III	2.3	6305	2875	125	3473	145T	T,C,S,X,IG
14	I	1.1	6356	2090	125	3363	145T	T,C,S,X,IG
13	I	1.0	6966	2090	140	3363	145T	T,C,S,X,IG
13	I, II, III	2.0	7067	2875	140	3473	145T	T,C,S,X,IG
11	I, II	1.8	7830	2875	160	3473	145T	T,C,S,X,IG
10.2	I, II	1.7	8399	2875	180	3475	145T	T,C,S,X,IG
10	I, II, III	2.7	8497	4100	180	3585	145T	T,C,S,X,IG
9.5	I, II, III	2.5	8985	4100	200	3585	145T	T,C,S,X,IG
9.0	I, II	1.5	9473	2875	200	3475	145T	T,C,S,X,IG
8.4	I, II, III	2.2	10157	4100	224	3585	145T	T,C,S,X,IG
8.0	I	1.3	10743	2875	224	3475	145T	T,C,S,X,IG
7.4	I, II, III	2.0	11475	4100	250	3585	145T	T,C,S,X,IG
7.0	I	1.2	12208	2875	250	3475	145T	T,C,S,X,IG
6.6	I, II	1.8	12940	4100	280	3585	145T	T,C,S,X,IG
6.1	I	1.0	13966	2875	280	3475	145T	T,C,S,X,IG
5.8	I, II	1.5	14747	4100	315	3585	145T	T,C,S,X,IG
5.8	III	2.7	14835	13249	315	3695	145T	T,C,S,X,IG
5.1	III	2.4	16651	13249	355	3695	145T	T,C,S,X,IG
5.1	I, II	1.4	16847	4100	355	3585	145T	T,C,S,X,IG
4.5	I	1.2	18995	4100	400	3585	145T	T,C,S,X,IG
4.4	II, III	2.1	19288	13249	400	3695	145T	T,C,S,X,IG
4.2	I	1.1	20167	4100	450	3585	145T	T,C,S,X,IG
4.1	II	1.9	20607	13249	450	3695	145T	T,C,S,X,IG
3.8	III	3+	22218	18242	450	3705	145T	T,C,S,X,IG
3.7	II	1.7	23390	13249	500	3695	145T	T,C,S,X,IG
3.6	I	1.0	23927	4100	500	3585	145T	T,C,S,X,IG
3.4	III	2.9	25197	18242	500	3705	145T	T,C,S,X,IG

◇ **Standard Motor Types** (see page B-15 for product codes)  
 T TEFC, three phase, 208-230/460 or 575 volts  
 S TEFC, single phase, 115/230 volts (Note that the frame is 145TY for single phase).  
 C Corro-Duty®, three phase, 230/460 or 575 volts  
 X Explosionproof, CI 1 group D, CI 2 groups F&G, three phase, 230/460 or 575 volts  
 IG IntelliGear® variable speed for 1-ph/230V, 3-ph/230V, or 3-ph/460V power supplies, NEMA 4/12

Δ Overhung load rating is at shaft midpoint.

## 1 1/2 HP (Continued)

General Specifications: Totally enclosed, 60 hertz, 40°C ambient, continuous duty.

Output RPM	AGMA Class	Service Factor	Output Torque in - lbs	OHL $\Delta$ lb	Nominal Ratio	Frame Size		Std. Motor Types $\diamond$
						Gear	Motor	
3.3	I, II	1.5	25978	13249	560	3695	145T	T,C,S,X,IG
3.1	III	2.6	27980	18242	560	3705	145T	T,C,S,X,IG
2.9	I	1.3	29543	13249	630	3695	145T	T,C,S,X,IG
2.7	II, III	2.3	31789	18242	630	3705	145T	T,C,S,X,IG
2.6	I	1.2	32863	13249	710	3695	145T	T,C,S,X,IG
2.4	II, III	2.1	35354	18242	710	3705	145T	T,C,S,X,IG
2.3	I	1.1	36965	13249	800	3695	145T	T,C,S,X,IG
2.2	III	3.1	38735	21873	800	3825	145T	T,C,S,X,IG
2.1	II	1.8	39787	18242	800	3705	145T	T,C,S,X,IG
2.1	III	2.9	41391	21873	900	3825	145T	T,C,S,X,IG
1.8	I, II	1.6	46634	18242	900	3705	145T	T,C,S,X,IG
1.8	III	2.5	46975	21873	1000	3825	145T	T,C,S,X,IG
1.7	I, II	1.4	51468	18242	1000	3705	145T	T,C,S,X,IG
1.6	III	2.3	52174	21873	1120	3825	145T	T,C,S,X,IG
1.5	I	1.3	56449	18242	1120	3705	145T	T,C,S,X,IG
1.4	II, III	2.0	59267	21873	1250	3825	145T	T,C,S,X,IG
1.3	I	1.2	63383	18242	1250	3705	145T	T,C,S,X,IG
1.3	II	1.8	65942	21873	1400	3825	145T	T,C,S,X,IG
1.2	I	1.1	71635	18242	1400	3705	145T	T,C,S,X,IG
1.2	II	1.6	74185	21873	1600	3825	145T	T,C,S,X,IG
1.1	I	1	79302	18242	1600	3705	145T	T,C,S,X,IG
1.0	II	1.4	86956	21873	1800	3825	145T	T,C,S,X,IG
0.89	I	1.2	95986	21873	2000	3825	145T	T,C,S,X,IG
0.81	I	1.1	105253	21873	2240	3825	145T	T,C,S,X,IG
0.70		0.97	122909	21873	2500	3825	145T	T,C,S,X,IG

OtN Series

$\diamond$  **Standard Motor Types** (see page B-15 for product codes)

T TEFC, three phase, 208-230/460 or 575 volts

S TEFC, single phase, 115/230 volts (Note that the frame is 145TY for single phase).

C Corro-Duty<sup>®</sup>, three phase, 230/460 or 575 volts

X Explosionproof, CI 1 group D, CI 2 groups F&G, three phase, 230/460 or 575 volts

IG IntelliGear<sup>®</sup> variable speed for 1-ph/230V, 3-ph/230V, or 3-ph/460V power supplies, NEMA 4/12

$\Delta$  Overhung load rating is at shaft midpoint.

## 2 HP

General Specifications: Totally enclosed, 60 hertz, 40°C ambient, continuous duty.

OtN Series

Output RPM	AGMA Class	Service Factor	Output Torque in - lbs	OHL Δ lb	Nominal Ratio	Frame Size Gear	Motor	Std. Motor Types ◇
472	I, II, III	3+	257	2071	3.55	3242	145T	T,C,S,X,IG
374	I, II, III	3+	324	2071	4.5	3242	145T	T,C,S,X,IG
343	I, II, III	2.8	353	1294	5	3132	145T	T,C,S,X,IG
313	I, II, III	3+	387	2071	5.6	3242	145T	T,C,S,X,IG
272	I, II, III	2.4	445	1294	6.3	3132	145T	T,C,S,X,IG
242	I, II, III	2.3	500	1294	7.1	3132	145T	T,C,S,X,IG
230	I, II, III	2.2	527	1294	8	3132	145T	T,C,S,X,IG
203	I, II, III	2.0	596	1294	9	3132	145T	T,C,S,X,IG
180	I, II	1.9	672	1294	10	3132	145T	T,C,S,X,IG
179	III	3+	664	1013	10	3243	145T	T,C,S,X,IG
159	I, II	1.7	761	1294	11.2	3132	145T	T,C,S,X,IG
141	III	3+	857	2071	12.5	3242	145T	T,C,S,X,IG
140	I, II	1.6	864	1294	12.5	3132	145T	T,C,S,X,IG
124	III	3+	975	2071	14	3242	145T	T,C,S,X,IG
122	I, II	1.5	989	1294	14	3132	145T	T,C,S,X,IG
112	II, III	3.0	1079	2071	16	3242	145T	T,C,S,X,IG
109	I	1.3	1113	1294	16	3132	145T	T,C,S,X,IG
102	I	1.3	1182	1294	18	3132	145T	T,C,S,X,IG
99	II, III	2.6	1224	2071	18	3242	145T	T,C,S,X,IG
89	II, III	2.3	1362	2071	20	3242	145T	T,C,S,X,IG
86	I	1.2	1404	1294	20	3132	145T	T,C,S,X,IG
81	I	1.1	1487	1294	22.4	3132	145T	T,C,S,X,IG
76	II, III	2.0	1583	2071	22.4	3242	145T	T,C,S,X,IG
73	III	2.3	1632	1238	25	3243	145T	T,C,S,X,IG
71	I	1.0	1701	1294	25	3132	145T	T,C,S,X,IG
67	II	1.8	1798	2071	25	3242	145T	T,C,S,X,IG
64		0.91	1895	1294	28	3132	145T	T,C,S,X,IG
64	III	2.0	1848	1252	28	3243	145T	T,C,S,X,IG
61	I, II	1.6	1985	2071	28	3242	145T	T,C,S,X,IG
57	III	3+	2072	2090	31.5	3363	145T	T,C,S,X,IG
56	I, II	1.5	2178	2071	31.5	3242	145T	T,C,S,X,IG
53	III	3+	2228	2090	35.5	3363	145T	T,C,S,X,IG
50	II	1.7	2356	1291	35.5	3243	145T	T,C,S,X,IG
48	I	1.3	2545	2071	35.5	3242	145T	T,C,S,X,IG
46	I, II, III	2.7	2597	2090	40	3363	145T	T,C,S,X,IG
44	I, II	1.5	2678	1306	40	3243	145T	T,C,S,X,IG
40	I, II, III	2.4	2963	2090	45	3363	145T	T,C,S,X,IG
39	I	1.3	3064	1316	45	3243	145T	T,C,S,X,IG
35	I, II, III	2.1	3410	2090	50	3363	145T	T,C,S,X,IG
34	I	1.1	3457	1319	50	3243	145T	T,C,S,X,IG

◇ **Standard Motor Types** (see page B-15 for product codes)  
T TEFC, three phase, 208-230/460 or 575 volts  
S TEFC, single phase, 115/230 volts (Note that the frame is 145TY for single phase)  
C Corro-Duty®, three phase, 230/460 or 575 volts  
X Explosionproof, CI 1 group D, CI 2 groups F&G, three phase, 230/460 or 575 volts  
IG IntelliGear® variable speed for 1-ph/230V, 3-ph/230V, or 3-ph/460V power supplies, NEMA 4/12

Δ Overhung load rating is at shaft midpoint.



## 2 HP (Continued)

General Specifications: Totally enclosed, 60 hertz, 40°C ambient, continuous duty.

Output RPM	AGMA Class	Service Factor	Output Torque in - lbs	OHL $\Delta$ lb	Nominal Ratio	Frame Size		Std. Motor Types $\diamond$
						Gear	Motor	
33	I, II	1.9	3647	2090	56	3363	145T	T,C,S,X,IG
32	I	1.1	3668	1319	56	3243	145T	T,C,S,X,IG
31	II, III	3+	3864	2875	56	3473	145T	T,C,S,X,IG
29	I, II	1.7	4135	2090	63	3363	145T	T,C,S,X,IG
28	III	3+	4196	2875	63	3473	145T	T,C,S,X,IG
26	I, II	1.5	4596	2090	71	3363	145T	T,C,S,X,IG
25	III	3+	4678	2875	71	3473	145T	T,C,S,X,IG
23	I, II	1.4	5220	2090	80	3363	145T	T,C,S,X,IG
23	III	2.7	5254	2875	80	3473	145T	T,C,S,X,IG
20	I	1.2	5810	2090	90	3363	145T	T,C,S,X,IG
20	II, III	2.4	5946	2875	90	3473	145T	T,C,S,X,IG
18	II, III	2.2	6468	2875	100	3473	145T	T,C,S,X,IG
18	I	1.1	6535	2090	100	3363	145T	T,C,S,X,IG
16	I, II	1.9	7322	2875	112	3473	145T	T,C,S,X,IG
14	III	2.8	8203	4100	125	3583	145T	T,C,S,X,IG
14	I, II	1.7	8406	2875	125	3473	145T	T,C,S,X,IG
13	III	2.5	9084	4100	140	3583	145T	T,C,S,X,IG
13	I, II	1.5	9423	2875	140	3473	145T	T,C,S,X,IG
11	I, II	1.4	10440	2875	160	3473	145T	T,C,S,X,IG
11	III	2.1	10779	4100	160	3583	145T	T,C,S,X,IG
10.2	I	1.3	11199	2875	180	3475	145T	T,C,S,X,IG
10	II, III	2.0	11329	4100	180	3585	145T	T,C,S,X,IG
9.5	I, II	1.9	11980	4100	200	3585	145T	T,C,S,X,IG
9.0	I	1.1	12631	2875	200	3475	145T	T,C,S,X,IG
8.4	I, II	1.7	13543	4100	224	3585	145T	T,C,S,X,IG
8.0	I	1.0	14324	2875	224	3475	145T	T,C,S,X,IG
7.4	I, II	1.5	15301	4100	250	3585	145T	T,C,S,X,IG
7.3	III	2.5	15558	13249	250	3695	145T	T,C,S,X,IG
6.6	I	1.3	17254	4100	280	3585	145T	T,C,S,X,IG
6.4	II, III	2.3	17633	13249	280	3695	145T	T,C,S,X,IG
5.8	I	1.2	19663	4100	315	3585	145T	T,C,S,X,IG
5.8	II, III	2.0	19447	13249	315	3695	145T	T,C,S,X,IG
5.1	I, II	1.8	22202	13249	355	3695	145T	T,C,S,X,IG
5.1	I	1	22463	4100	355	3585	145T	T,C,S,X,IG
4.8	III	3+	23895	18242	355	3705	145T	T,C,S,X,IG

$\diamond$  Standard Motor Types (see page B-15 for product codes)

T TEFC, three phase, 208-230/460 or 575 volts

S TEFC, single phase, 115/230 volts (Note that the frame is 145TY for single phase)

C Corro-Duty<sup>®</sup>, three phase, 230/460 or 575 volts

X Explosionproof, Cl 1 group D, Cl 2 groups F&G, three phase, 230/460 or 575 volts

IG IntelliGear<sup>®</sup> variable speed for 1-ph/230V, 3-ph/230V, or 3-ph/460V power supplies, NEMA 4/12

$\Delta$  Overhung load rating is at shaft midpoint.

## 2 HP (Continued)

General Specifications: Totally enclosed, 60 hertz, 40°C ambient, continuous duty.

OtN Series

Output RPM	AGMA Class	Service Factor	Output Torque in - lbs	OHL Δ lb	Nominal Ratio	Frame Size Gear	Motor	Std. Motor Types ◇
4.4	I, II	1.5	25718	13249	400	3695	145T	T,C,S,X,IG
4.1	I, II	1.4	27476	13249	450	3695	145T	T,C,S,X,IG
4.1	III	2.6	27671	18242	400	3705	145T	T,C,S,X,IG
3.8	III	2.5	29624	18242	450	3705	145T	T,C,S,X,IG
3.7	I	1.3	31187	13249	500	3695	145T	T,C,S,X,IG
3.4	II, III	2.2	33596	18242	500	3705	145T	T,C,S,X,IG
3.3	I	1.1	34637	13249	560	3695	145T	T,C,S,X,IG
3.1	II, III	2.0	37307	18242	560	3705	145T	T,C,S,X,IG
2.9	I	1	39390	13249	630	3695	145T	T,C,S,X,IG
2.9	III	3.0	39483	21873	630	3825	145T	T,C,S,X,IG
2.7	II	1.7	42385	13249	630	3705	145T	T,C,S,X,IG
2.5	III	2.7	44807	21873	710	3825	145T	T,C,S,X,IG
2.4	I, II	1.6	47138	18242	710	3705	145T	T,C,S,X,IG
2.2	III	2.3	51646	21873	800	3825	145T	T,C,S,X,IG
2.1	I, II	1.4	53063	18242	800	3705	145T	T,C,S,X,IG
2.1	II, III	2.2	55188	21873	900	3825	145T	T,C,S,X,IG
1.8	I	1.2	62178	18242	900	3705	145T	T,C,S,X,IG
1.8	II	1.9	62633	21873	1000	3825	145T	T,C,S,X,IG
1.7	I	1.1	68624	18242	1000	3705	145T	T,C,S,X,IG
1.6	II	1.7	69565	21873	1120	3825	145T	T,C,S,X,IG
1.5		0.97	75265	18242	1120	3705	145T	T,C,S,X,IG
1.4	I, II	1.5	79023	21873	1250	3825	145T	T,C,S,X,IG
1.3	I, II	1.4	87922	21873	1400	3825	145T	T,C,S,X,IG
1.2	I	1.2	98913	21873	1600	3825	145T	T,C,S,X,IG
1.0	I	1.0	115941	21873	1800	3825	145T	T,C,S,X,IG

◇ **Standard Motor Types** (see page B-15 for product codes)  
 T TEFC, three phase, 208-230/460 or 575 volts  
 S TEFC, single phase, 115/230 volts (Note that the frame is 145TY for single phase)  
 C Corro-Duty®, three phase, 230/460 or 575 volts  
 X Explosionproof, CI 1 group D, CI 2 groups F&G, three phase, 230/460 or 575 volts  
 IG IntelliGear® variable speed for 1-ph/230V, 3-ph/230V, or 3-ph/460V power supplies, NEMA 4/12  
 Δ Overhung load rating is at shaft midpoint.

## 3 HP

General Specifications: Totally enclosed, 60 hertz, 40°C ambient, continuous duty.

Output RPM	AGMA Class	Service Factor	Output Torque in - lbs	OHL $\Delta$ lb	Nominal Ratio	Frame Size		Std. Motor Types $\diamond$
						Gear	Motor	
472	I, II, III	3+	385	1756	3.55	3242	182T	T,C,S,X,IG
374	I, II, III	3+	485	1868	4.5	3242	182T	T,C,S,X,IG
343	I, II	1.9	529	1294	5	3132	182T	T,C,S,X,IG
313	I, II, III	3+	581	1957	5.6	3242	182T	T,C,S,X,IG
272	I, II	1.6	667	1294	6.3	3132	182T	T,C,S,X,IG
265	III	3+	686	1294	6.3	3242	182T	T,C,S,X,IG
248	III	3+	731	1294	7.1	3242	182T	T,C,S,X,IG
242	I, II	1.5	750	1294	7.1	3132	182T	T,C,S,X,IG
230	I, II	1.5	790	1294	8	3132	182T	T,C,S,X,IG
220	III	3+	827	2071	8	3242	182T	T,C,S,X,IG
203	I	1.3	894	1294	9	3132	182T	T,C,S,X,IG
198	II, III	3+	916	2071	9	3242	182T	T,C,S,X,IG
180	I, II, III	1.2	1008	1294	10	3132	182T	T,C,S,X,IG
173	III	3.0	1048	2071	10	3242	182T	T,C,S,X,IG
159	I	1.1	1141	1294	11.2	3132	182T	T,C,S,X,IG
151	II, III	2.6	1203	2071	11.2	3242	182T	T,C,S,X,IG
141	II, III	2.5	1286	2071	12.5	3242	182T	T,C,S,X,IG
140	I	1.1	1297	1294	12.5	3132	182T	T,C,S,X,IG
124	I, II, III	2.2	1462	2071	14	3242	182T	T,C,S,X,IG
122		0.9	1483	1294	14	3132	182T	T,C,S,X,IG
112	I, II, III	2.0	1618	2071	16	3242	182T	T,C,S,X,IG
99	I, II	1.7	1836	2071	18	3242	182T	T,C,S,X,IG
94	III	3.3	1889	2090	20	3363	182T	T,C,S,X,IG
89	I, II	1.6	2043	2071	20	3242	182T	T,C,S,X,IG
79	I, II	1.4	2303	2071	22.4	3242	182T	T,C,S,X,IG
75	III	2.9	2366	2090	22.4	3363	182T	T,C,S,X,IG
73	I, II	1.5	2500	1074	25	3243	182T	T,C,S,X,IG
72	III	2.8	2468	2090	25	3363	182T	T,C,S,X,IG
67	I	1.2	2697	2071	25	3242	182T	T,C,S,X,IG
64	II	1.4	2773	1077	28	3243	182T	T,C,S,X,IG
61	I	1.1	2977	2071	28	3242	182T	T,C,S,X,IG
61	II, III	2.5	2915	2090	28	3363	182T	T,C,S,X,IG
57	II, III	2.3	3112	2090	31.5	3363	182T	T,C,S,X,IG
57	I	1.2	3132	1075	31.5	3243	182T	T,C,S,X,IG
51	II, III	2.0	3518	2090	35.5	3363	182T	T,C,S,X,IG
50	I	1.1	3539	1068	35.5	3243	182T	T,C,S,X,IG
46	I, II	1.8	3895	2090	40	3363	182T	T,C,S,X,IG
44	I	1.0	4017	1052	40	3243	182T	T,C,S,X,IG
44	II, III	3+	4057	2875	40	3473	182T	T,C,S,X,IG
40	I, II	1.6	4444	2090	45	3363	182T	T,C,S,X,IG

$\diamond$  **Standard Motor Types** (see page B-15 for product codes)

T TEFC, three phase, 208-230/460 or 575 volts

S TEFC, single phase, 230 volts (Note that single phase motor has 184T frame.)

C Corro-Duty<sup>®</sup>, three phase, 230/460 or 575 volts

X Explosionproof, CI 1 group D, CI 2 groups F&G, three phase, 230/460 or 575 volts

IG IntelliGear<sup>®</sup> variable speed for 3-ph/230V or 3-ph/460V power supplies, NEMA 4/12

$\Delta$  Overhung load rating is at shaft midpoint.

## 3 HP (Continued)

General Specifications: Totally enclosed, 60 hertz, 40°C ambient, continuous duty.

OtN Series

Output RPM	AGMA Class	Service Factor	Output Torque in - lbs	OHL $\Delta$ lb	Nominal Ratio	Frame Size Gear	Motor	Std. Motor Types $\diamond$
40	III	3+	4485	2875	45	3473	182T	T,C,S,X,IG
35	I, II	1.4	5115	2090	50	3363	182T	T,C,S,X,IG
35	III	2.6	5146	2875	50	3473	182T	T,C,S,X,IG
33	I	1.3	5471	2090	56	3363	182T	T,C,S,X,IG
31	I, II, III	2.4	5796	2875	56	3473	182T	T,C,S,X,IG
29	I	1.1	6203	2090	63	3363	182T	T,C,S,X,IG
28	I, II, III	2.2	6295	2875	63	3473	182T	T,C,S,X,IG
26	I	1.0	6895	2090	71	3363	182T	T,C,S,X,IG
25	I, II, III	2.0	7017	2875	71	3473	182T	T,C,S,X,IG
23	I, II	1.8	7881	2875	80	3473	182T	T,C,S,X,IG
22	I, II, III	2.8	8196	4100	80	3583	182T	T,C,S,X,IG
20	I, II, III	2.6	8796	4100	90	3583	182T	T,C,S,X,IG
20	I, II	1.6	8918	2875	90	3473	182T	T,C,S,X,IG
18	I, II	1.5	9701	2875	100	3473	182T	T,C,S,X,IG
17	I, II, III	2.2	10271	4100	100	3583	182T	T,C,S,X,IG
16	I	1.3	10983	2875	112	3473	182T	T,C,S,X,IG
16	I, II, III	2.1	11084	4100	112	3583	182T	T,C,S,X,IG
14	I, II	1.9	12305	4100	125	3583	182T	T,C,S,X,IG
14	I	1.1	12610	2875	125	3473	182T	T,C,S,X,IG
14	III	3+	12304	13249	125	3693	182T	T,C,S,X,IG
13	III	2.9	13728	13249	140	3693	182T	T,C,S,X,IG
13	I, II	1.7	13627	4100	140	3583	182T	T,C,S,X,IG
13	I	1.0	14135	2875	140	3473	182T	T,C,S,X,IG
11	III	2.5	15965	13249	160	3693	182T	T,C,S,X,IG
11	I, II	1.4	16169	4100	160	3583	182T	T,C,S,X,IG
10.1	I	1.3	16993	4100	180	3585	182T	T,C,S,X,IG
9.7	II, III	2.3	17502	13249	180	3695	182T	T,C,S,X,IG
9.5	I	1.3	17970	4100	200	3585	182T	T,C,S,X,IG
9.2	II, III	2.0	18572	13249	200	3695	182T	T,C,S,X,IG
8.4	I	1.1	20314	4100	224	3585	182T	T,C,S,X,IG
7.7	II	1.9	21879	13249	224	3695	182T	T,C,S,X,IG
7.6	III	3+	22462	18242	224	3705	182T	T,C,S,X,IG
7.4	I	1.0	22951	4100	250	3585	182T	T,C,S,X,IG
7.3	II	1.7	23337	13249	250	3695	182T	T,C,S,X,IG
6.7	III	2.9	25490	18242	250	3705	182T	T,C,S,X,IG
6.4	I, II	1.5	26449	13249	280	3695	182T	T,C,S,X,IG
6.0	II, III	2.6	28322	18242	280	3705	182T	T,C,S,X,IG
5.8	I	1.3	29172	13249	315	3695	182T	T,C,S,X,IG
5.3	II, III	2.3	32228	18242	315	3705	182T	T,C,S,X,IG
5.1	I	1.2	33303	13249	355	3695	182T	T,C,S,X,IG

$\diamond$  **Standard Motor Types** (see page B-15 for product codes)  
T TEFC, three phase, 208-230/460 or 575 volts  
S TEFC, single phase, 230 volts (Note that single phase motor has 184T frame.)  
C Corro-Duty®, three phase, 230/460 or 575 volts  
X Explosionproof, CI 1 group D, CI 2 groups F&G, three phase, 230/460 or 575 volts  
IG IntelliGear® variable speed for 3-ph/230V or 3-ph/460V power supplies, NEMA 4/12

$\Delta$  Overhung load rating is at shaft midpoint.

## 3 HP (Continued)

General Specifications: Totally enclosed, 60 hertz, 40°C ambient, continuous duty.

Output RPM	AGMA Class	Service Factor	Output Torque in - lbs	OHL $\Delta$ lb	Nominal Ratio	Frame Size Gear	Motor	Std. Motor Types $\diamond$
4.8	II, III	2.0	35842	18242	355	3705	182T	T,C,S,X,IG
4.4	I	1.0	39065	13249	400	3695	182T	T,C,S,X,IG
4.4	II, III	3.1	38936	21873	400	3825	182T	T,C,S,X,IG
4.1	I, II	1.8	41506	18242	400	3705	182T	T,C,S,X,IG
4.1	III	2.9	41526	21873	450	3825	182T	T,C,S,X,IG
3.8	I, II	1.6	44436	18242	450	3705	182T	T,C,S,X,IG
3.6	III	2.5	46966	21873	500	3825	182T	T,C,S,X,IG
3.4	I, II	1.5	50394	18242	500	3705	182T	T,C,S,X,IG
3.3	III	2.3	51973	21873	560	3825	182T	T,C,S,X,IG
3.1	I	1.3	55960	18242	560	3705	182T	T,C,S,X,IG
2.9	I, II	2.0	59224	21873	630	3825	182T	T,C,S,X,IG
2.7	I	1.2	63578	18242	630	3705	182T	T,C,S,X,IG
2.5	II	1.8	67210	21873	710	3825	182T	T,C,S,X,IG
2.4	I	1.0	70707	18242	710	3705	182T	T,C,S,X,IG
2.2	I, II	1.5	77470	21873	800	3825	182T	T,C,S,X,IG
2.1	I, II	1.4	82782	21873	900	3825	182T	T,C,S,X,IG
1.8	I	1.3	93950	21873	1000	3825	182T	T,C,S,X,IG
1.6	I	1.1	104347	21873	1120	3825	182T	T,C,S,X,IG
1.4	I	1.0	118535	21873	1250	3825	182T	T,C,S,X,IG

$\diamond$  **Standard Motor Types** (see page B-15 for product codes)

- T TEFC, three phase, 208-230/460 or 575 volts
- S TEFC, single phase, 230 volts (Note that single phase motor has 184T frame.)
- C Corro-Duty<sup>®</sup>, three phase, 230/460 or 575 volts
- X Explosionproof, CI 1 group D, CI 2 groups F&G, three phase, 230/460 or 575 volts
- IG IntelliGear<sup>®</sup> variable speed for 3-ph/230V or 3-ph/460V power supplies, NEMA 4/12

$\Delta$  Overhung load rating is at shaft midpoint.

## 5 HP

General Specifications: Totally enclosed, 60 hertz, 40°C ambient, continuous duty.

OtN Series

Output RPM	AGMA Class	Service Factor	Output Torque in - lbs	OHL $\Delta$ lb	Nominal Ratio	Frame Size Gear	Motor	Std. Motor Types $\diamond$
472	I, II, III	4.2	641	1704	3.55	3242	184T	T,C,S,X,IG
374	I, II, III	3.7	809	1803	4.5	3242	184T	T,C,S,X,IG
343	I	1.1	882	1294	5	3132	184T	T,C,S,X,IG
313	I, II, III	3.3	968	1850	5.6	3242	184T	T,C,S,X,IG
265	I, II, III	2.8	1143	1906	6.3	3242	184T	T,C,S,X,IG
248	I, II, III	2.6	1219	1977	7.1	3242	184T	T,C,S,X,IG
220	I, II, III	2.3	1378	2028	8	3242	184T	T,C,S,X,IG
198	I, II, III	2.1	1526	2070	9	3242	184T	T,C,S,X,IG
179	III	3.3	1655	1771	10	3363	184T	T,C,S,X,IG
173	I, II	1.8	1746	2071	10	3242	184T	T,C,S,X,IG
151	I, II	1.6	2005	2071	11.2	3242	184T	T,C,S,X,IG
142	III	2.7	2082	1866	12.5	3363	184T	T,C,S,X,IG
141	I, II	1.5	2144	2071	12.5	3242	184T	T,C,S,X,IG
124	I	1.3	2437	2071	14	3242	184T	T,C,S,X,IG
118	II, III	2.4	2505	1941	14	3363	184T	T,C,S,X,IG
112	I	1.2	2697	2071	16	3242	184T	T,C,S,X,IG
109	II, III	2.3	2725	1963	16	3363	184T	T,C,S,X,IG
99	I	1.0	3060	2071	18	3242	184T	T,C,S,X,IG
94	II, III	2.0	3148	2026	18	3363	184T	T,C,S,X,IG
86	I, II, III	2.0	3441	2057	20	3363	184T	T,C,S,X,IG
86	I	1.0	3457	800	20	3243	184T	T,C,S,X,IG
82	I, II, III	3+	3610	2875	22.4	3473	184T	T,C,S,X,IG
75	I, II	1.7	3949	2090	22.4	3363	184T	T,C,S,X,IG
72	I, II	1.7	4118	2090	25	3363	184T	T,C,S,X,IG
71	III	3+	4203	2875	25	3473	184T	T,C,S,X,IG
61	III	2.7	4847	2875	28	3473	184T	T,C,S,X,IG
61	I, II	1.5	4864	2090	28	3363	184T	T,C,S,X,IG
57	I, II	1.4	5186	2090	31.5	3363	184T	T,C,S,X,IG
56	III	2.5	5339	2875	31.5	3473	184T	T,C,S,X,IG
51	I	1.2	5864	2090	35.5	3363	184T	T,C,S,X,IG
50	III	2.3	5898	2875	35.5	3473	184T	T,C,S,X,IG
46	I	1.1	6491	2090	40	3363	184T	T,C,S,X,IG
44	I, II, III	2.0	6762	2875	40	3473	184T	T,C,S,X,IG
41	III	3+	7220	4100	45	3583	184T	T,C,S,X,IG
40	I, II	1.8	7474	2875	45	3473	184T	T,C,S,X,IG
35	III	2.7	8440	4100	50	3583	184T	T,C,S,X,IG
35	I, II	1.6	8576	2875	50	3473	184T	T,C,S,X,IG
32	III	2.4	9406	4100	56	3583	184T	T,C,S,X,IG
31	I, II	1.4	9661	2875	56	3473	184T	T,C,S,X,IG
28	I	1.3	10491	2875	63	3473	184T	T,C,S,X,IG
28	II, III	2.1	10576	4100	63	3583	184T	T,C,S,X,IG

$\diamond$  **Standard Motor Types** (see page B-15 for product codes)  
 T TEFC, three phase, 208-230/460 or 575 volts  
 S TEFC, single phase, 230 volts  
 C Corro-Duty®, three phase, 230/460 or 575 volts  
 X Explosionproof, CI 1 group D, CI 2 groups F&G, three phase, 230/460 or 575 volts  
 IG IntelliGear® variable speed for 3-ph/230V or 3-ph/460V power supplies, NEMA 4/12

$\Delta$  Overhung load rating is at shaft midpoint.



## 5 HP (Continued)

General Specifications: Totally enclosed, 60 hertz, 40°C ambient, continuous duty.

Output RPM	AGMA Class	Service Factor	Output Torque in - lbs	OHL Δ lb	Nominal Ratio	Frame Size Gear	Motor	Std. Motor Types ◇
25	III	3+	11796	12633	71	3693	184T	T,C,S,X,IG
25	I	1.2	11694	2875	71	3473	184T	T,C,S,X,IG
25	II	1.9	11966	4100	71	3583	184T	T,C,S,X,IG
23	III	3+	12864	12956	80	3693	184T	T,C,S,X,IG
23	I	1.1	13135	2875	80	3473	184T	T,C,S,X,IG
22	II	1.7	13660	4100	80	3583	184T	T,C,S,X,IG
21	III	2.7	14457	13249	90	3693	184T	T,C,S,X,IG
20	I, II	1.6	14660	4100	90	3583	184T	T,C,S,X,IG
18	II, II	2.5	16118	13249	100	3693	184T	T,C,S,X,IG
17	I	1.3	17118	4100	100	3583	184T	T,C,S,X,IG
16	II, III	2.2	18304	13249	112	3693	184T	T,C,S,X,IG
16	I	1.2	18474	4100	112	3583	184T	T,C,S,X,IG
14	III	3+	20846	18242	125	3703	184T	T,C,S,X,IG
14	II	1.9	21016	13249	125	3693	184T	T,C,S,X,IG
14	I	1.1	20508	4100	125	3583	184T	T,C,S,X,IG
13	I	1.0	22711	4100	140	3583	184T	T,C,S,X,IG
13	II	1.8	22880	13249	140	3693	184T	T,C,S,X,IG
13	III	3+	22880	18242	140	3703	184T	T,C,S,X,IG
12	III	2.9	25761	18242	160	3703	184T	T,C,S,X,IG
11	I, II	1.5	26609	13249	160	3693	184T	T,C,S,X,IG
9.7	I, II	1.4	29171	13242	180	3695	184T	T,C,S,X,IG
9.4	III	2.3	31693	18242	180	3705	184T	T,C,S,X,IG
9.1	I	1.2	30954	13249	200	3695	184T	T,C,S,X,IG
8.1	II, III	2.0	36608	18242	200	3705	184T	T,C,S,X,IG
7.8	I	1.1	36464	13242	224	3695	184T	T,C,S,X,IG
7.6	II, III	2.0	37437	18242	224	3705	184T	T,C,S,X,IG
7.3	I	1.0	38895	13249	250	3695	184T	T,C,S,X,IG
6.7	II	1.7	42483	18242	250	3705	184T	T,C,S,X,IG
6.0	I, II	1.5	47203	18242	280	3705	184T	T,C,S,X,IG
5.3	I, II	1.4	53714	18242	315	3705	184T	T,C,S,X,IG
5.2	II, III	2.1	54894	21873	355	3825	184T	T,C,S,X,IG
4.8	I	1.2	59737	18242	355	3705	184T	T,C,S,X,IG
4.4	II	1.8	64893	21873	400	3825	184T	T,C,S,X,IG
4.1	II	1.7	69210	21873	450	3825	184T	T,C,S,X,IG
4.1	I	1.1	69177	18242	400	3705	184T	T,C,S,X,IG
3.8	I	1	74060	18242	450	3705	184T	T,C,S,X,IG
3.6	I, II	1.5	78276	21873	500	3825	184T	T,C,S,X,IG
3.3	I, II	1.4	86621	21873	560	3825	184T	T,C,S,X,IG
2.9	I	1.2	98707	21873	630	3825	184T	T,C,S,X,IG
2.5	I	1.1	112017	21873	710	3825	184T	T,C,S,X,IG

◇ **Standard Motor Types** (see page B-15 for product codes)  
 T TEFC, three phase, 208-230/460 or 575 volts  
 S TEFC, single phase, 230 volts  
 C Corro-Duty®, three phase, 230/460 or 575 volts  
 X Explosionproof, CI 1 group D, CI 2 groups F&G, three phase, 230/460 or 575 volts  
 IG IntelliGear® variable speed for 3-ph/230V or 3-ph/460V power supplies, NEMA 4/12

Δ Overhung load rating is at shaft midpoint.

OtN Series

## 7 1/2 HP

General Specifications: Totally enclosed, 60 hertz, 40°C ambient, continuous duty.

OtN Series

Output RPM	AGMA Class	Service Factor	Output Torque in - lbs	OHL $\Delta$ lb	Nominal Ratio	Frame Size Gear	Motor	Std. Motor Types $\diamond$
472	I, II, III	2.8	962	1639	3.55	3242	213T	T,C,X,IG
374	I, II, III	2.5	1214	1721	4.5	3242	213T	T,C,X,IG
313	I, II, III	2.2	1462	1735	5.6	3242	213T	T,C,X,IG
265	I, II, III	1.9	1714	1834	6.3	3242	213T	T,C,X,IG
248	I, II	1.7	1828	1854	7.1	3242	213T	T,C,X,IG
220	I, II	1.5	2067	1889	8	3242	213T	T,C,X,IG
198	I, II	1.4	2290	1916	9	3242	213T	T,C,X,IG
179	II, III	2.2	2483	1644	10	3363	213T	T,C,X,IG
173	I	1.2	2619	1947	10	3242	213T	T,C,X,IG
151	I	1.1	3008	1974	11.2	3242	213T	T,C,X,IG
142	I, II	1.8	3123	1707	12.5	3363	213T	T,C,X,IG
142	III	3.1	3123	2875	12.5	3473	213T	T,C,X,IG
141		0.99	3215	2071	12.5	3242	213T	T,C,X,IG
118	I, II	1.6	3763	1750	14	3363	213T	T,C,X,IG
115	I, II, III	3+	3864	2875	14	3473	213T	T,C,X,IG
113	I, II, III	3+	3941	2875	16	3473	213T	T,C,X,IG
109	I, II	1.6	4093	1765	16	3363	213T	T,C,X,IG
100	I, II, III	2.6	4449	2875	18	3473	213T	T,C,X,IG
94	I	1.3	4729	1786	18	3363	213T	T,C,X,IG
87	I, II, III	2.4	5110	2875	20	3473	213T	T,C,X,IG
86	I	1.3	5161	1794	20	3363	213T	T,C,X,IG
82	I, II, III	2.1	5415	2875	22.4	3473	213T	T,C,X,IG
75	I	1.1	5923	1800	22.4	3363	213T	T,C,X,IG
72	I	1.1	6178	1799	25	3363	213T	T,C,X,IG
71	I, II, III	2.0	6305	2875	25	3473	213T	T,C,X,IG
65	I, II, III	3+	6890	4100	28	3583	213T	T,C,X,IG
61	II	1.8	7271	2875	28	3473	213T	T,C,X,IG
61	I	1.0	7296	1785	28	3363	213T	T,C,X,IG
57	III	2.8	7754	4100	31.5	3583	213T	T,C,X,IG
56	I, II	1.7	8008	2875	31.5	3473	213T	T,C,X,IG
51	III	2.6	8644	4100	35.5	3583	213T	T,C,X,IG
50	I, II	1.5	8847	2875	35.5	3473	213T	T,C,X,IG
45	III	2.3	9813	4100	40	3583	213T	T,C,X,IG
44	I	1.3	10144	2875	40	3473	213T	T,C,X,IG
41	II, III	2.1	10830	4100	45	3583	213T	T,C,X,IG
40	I	1.2	11211	2875	45	3473	213T	T,C,X,IG
37	III	3+	12152	11250	50	3693	213T	T,C,X,IG
35	II	1.8	12660	4100	50	3583	213T	T,C,X,IG
35	I	1.0	12864	2875	50	3473	213T	T,C,X,IG
32	III	2.8	13830	11485	56	3693	213T	T,C,X,IG

$\diamond$  **Standard Motor Types** (see page B-15 for product codes)  
 T TEFC, three phase, 208-230/460 or 575 volts  
 C Corro-Duty®, three phase, 230/460 or 575 volts  
 X Explosionproof, CI 1 group D, CI 2 groups F&G, three phase, 230/460 or 575 volts  
 IG IntelliGear® variable speed for 3-ph/460V power supplies, NEMA 4/12  
 $\Delta$  Overhung load rating is at shaft midpoint.

## 7 1/2 HP (Continued)

General Specifications: Totally enclosed, 60 hertz, 40°C ambient, continuous duty.

Output RPM	AGMA Class	Service Factor	Output Torque in - lbs	OHL $\Delta$ lb	Nominal Ratio	Frame Size		Std. Motor Types $\diamond$
						Gear	Motor	
32	I,II	1.6	14110	4100	56	3583	213T	T,C,X,IG
29	III	2.6	15279	11667	63	3693	213T	T,C,X,IG
28	I, II	1.4	15864	4100	63	3583	213T	T,C,X,IG
25	II, III	2.2	17694	12097	71	3693	213T	T,C,X,IG
25	I	1.3	17948	4100	71	3583	213T	T,C,X,IG
23	II, III	2.1	19296	12349	80	3693	213T	T,C,X,IG
21	I, II	1.8	21685	12686	90	3693	213T	T,C,X,IG
20	III	3+	22219	18242	90	3703	213T	T,C,X,IG
18	I, II	1.6	24177	12995	100	3693	213T	T,C,X,IG
18	III	3.0	24914	18242	100	3703	213T	T,C,X,IG
16	I, II	1.5	27456	13249	112	3693	213T	T,C,X,IG
14	II, III	2.4	31269	18242	125	3703	213T	T,C,X,IG
14	I	1.3	31524	13249	125	3693	213T	T,C,X,IG
13	I	1.2	34320	13249	140	3693	213T	T,C,X,IG
13	II, III	2.1	34320	18242	140	3703	213T	T,C,X,IG
12	II	1.9	38593	18242	160	3703	213T	T,C,X,IG
11	III	3.1	39150	20214	160	3823	213T	T,C,X,IG
11	I	1.0	39913	13249	160	3693	213T	T,C,X,IG
9.4	I, II	1.6	45857	18242	180	3705	213T	T,C,X,IG
8.1	I, II	1.4	52738	18242	200	3705	213T	T,C,X,IG
7.6	I, II	1.3	56156	18242	224	3705	213T	T,C,X,IG
6.7	I, II	1.1	63725	18242	250	3705	213T	T,C,X,IG
6.0	I, II	1	70805	18242	280	3705	213T	T,C,X,IG
5	I, II	1.4	82341	21873	355	3825	213T	T,C,X,IG
4	I	1.2	97340	21873	400	3825	213T	T,C,X,IG
4	I	1.2	103815	21873	450	3825	213T	T,C,X,IG
4	I	1.0	117414	21873	500	3825	213T	T,C,X,IG

OtN Series

$\diamond$  **Standard Motor Types** (see page B-15 for product codes)  
T TEFC, three phase, 208-230/460 or 575 volts  
C Corro-Duty®, three phase, 230/460 or 575 volts  
X Explosionproof, Cl 1 group D, Cl 2 groups F&G, three phase, 230/460 or 575 volts  
IG IntelliGear® variable speed for 3-ph/460V power supplies, NEMA 4/12  
 $\Delta$  Overhung load rating is at shaft midpoint.

## 10 HP

General Specifications: Totally enclosed, 60 hertz, 40°C ambient, continuous duty.

OtN Series

Output RPM	AGMA Class	Service Factor	Output Torque in - lbs	OHL $\Delta$ lb	Nominal Ratio	Frame Size Gear	Motor	Std. Motor Types $\diamond$
472	I, II, III	2.1	1283	1575	3.55	3242	215T	T,C,X,IG
374	I, II	1.9	1618	1639	4.5	3242	215T	T,C,X,IG
313	I, II	1.6	1936	1670	5.6	3242	215T	T,C,X,IG
265	I, II	1.4	2285	1719	6.3	3242	215T	T,C,X,IG
248	I	1.3	2437	1731	7.1	3242	215T	T,C,X,IG
220	I	1.2	2756	1750	8	3242	215T	T,C,X,IG
198	I	1.0	3053	1762	9	3242	215T	T,C,X,IG
179	III	2.5	3311	2761	10	3473	215T	T,C,X,IG
179	I, II	1.7	3311	1539	10	3363	215T	T,C,X,IG
173		0.91	3492	1850	10	3242	215T	T,C,X,IG
142	I	1.3	4169	1549	12.5	3363	215T	T,C,X,IG
142	I, II, III	2.3	4169	2875	12.5	3473	215T	T,C,X,IG
118	I	1.2	5017	1558	14	3363	215T	T,C,X,IG
115	I, II, III	2.2	5152	2875	14	3473	215T	T,C,X,IG
113	I, II, III	2.2	5254	2875	16	3473	215T	T,C,X,IG
109	I	1.2	5457	1557	16	3363	215T	T,C,X,IG
100	I, II, III	2.0	5932	2875	18	3473	215T	T,C,X,IG
94	I	1.0	6305	1546	18	3363	215T	T,C,X,IG
88	I, II, III	2.9	6779	4100	20	3583	215T	T,C,X,IG
87	I, II	1.8	6813	2875	20	3473	215T	T,C,X,IG
86	I	1.0	6881	1532	20	3363	215T	T,C,X,IG
82	I, II	1.6	7220	2875	22.4	3473	215T	T,C,X,IG
74	I, II, III	2.6	8000	4100	22.4	3583	215T	T,C,X,IG
72	III	2.6	8237	4100	25	3583	215T	T,C,X,IG
71	I, II	1.5	8406	2875	25	3473	215T	T,C,X,IG
65	I, II, III	2.3	9186	4100	28	3583	215T	T,C,X,IG
61	I	1.3	9694	2875	28	3473	215T	T,C,X,IG
57	I, II, III	2.1	10338	4100	31.5	3583	215T	T,C,X,IG
56	I	1.3	10677	2875	31.5	3473	215T	T,C,X,IG
51	I, II	1.9	11525	4100	35.5	3583	215T	T,C,X,IG
50	I	1.1	11796	2875	35.5	3473	215T	T,C,X,IG
45	I, II	1.7	13084	4100	40	3583	215T	T,C,X,IG
45	III	2.9	13287	10115	40	3693	213T	T,C,X,IG
44	I	1.0	13525	2875	40	3473	215T	T,C,X,IG
41	I, II	1.6	14440	4100	45	3583	215T	T,C,X,IG
40	III	2.6	14948	10414	45	3693	215T	T,C,X,IG
37	III	2.4	16202	10619	50	3693	215T	T,C,X,IG
35	I	1.3	16880	4100	50	3583	215T	T,C,X,IG
32	III	2.1	18440	10941	56	3693	215T	T,C,X,IG
32	I, II	1.6	14110	4100	56	3583	215T	T,C,X,IG

$\diamond$  **Standard Motor Types** (see page B-15 for product codes)  
T TEFC, three phase, 208-230/460 or 575 volts  
C Corro-Duty®, three phase, 230/460 or 575 volts  
X Explosionproof, Cl 1 group D, Cl 2 groups F&G, three phase, 230/460 or 575 volts  
IG IntelliGear® variable speed for 3-ph/460V power supplies, NEMA 4/12

$\Delta$  Overhung load rating is at shaft midpoint.

## 10 HP (Continued)

General Specifications: Totally enclosed, 60 hertz, 40°C ambient, continuous duty.

Output RPM	AGMA Class	Service Factor	Output Torque in - lbs	OHL $\Delta$ lb	Nominal Ratio	Frame Size		Std. Motor Types $\diamond$
						Gear	Motor	
29	II	1.9	20372	11187	63	3693	215T	T,C,X,IG
28	I	1.1	21151	4100	63	3583	215T	T,C,X,IG
28	III	3.3	21422	16900	63	3703	215T	T,C,X,IG
25	III	3.1	23355	17304	71	3703	215T	T,C,X,IG
25	I, II	1.7	23592	11541	71	3693	215T	T,C,X,IG
23	I, II	1.5	25727	11743	80	3693	215T	T,C,X,IG
22	III	2.7	27253	18036	80	3703	215T	T,C,X,IG
21	I, II	1.4	28914	12005	90	3693	215T	T,C,X,IG
20	III	2.5	29625	18242	90	3703	215T	T,C,X,IG
18	I	1.2	32235	12236	100	3693	215T	T,C,X,IG
18	II, III	2.2	33218	18242	100	3703	215T	T,C,X,IG
16	I	1.1	36608	12485	112	3693	215T	T,C,X,IG
16	II, III	2.0	36947	18242	112	3703	215T	T,C,X,IG
14		0.95	42220	12500	125	3693	215T	T,C,X,IG
14	I, II	1.8	41879	18242	125	3703	215T	T,C,X,IG
14	III	2.8	43387	18945	125	3823	215T	T,C,X,IG
13	I, II	1.6	45965	18242	140	3703	215T	T,C,X,IG
13	III	2.6	46438	19265	140	3823	215T	T,C,X,IG
11	I, II	1.4	51753	18242	160	3703	215T	T,C,X,IG
11	III	2.3	52200	19790	160	3823	215T	T,C,X,IG
9.4	I	1.2	60876	18242	180	3705	215T	T,C,X,IG
8.1	I	1.0	70317	18242	200	3705	215T	T,C,X,IG
7.6		0.98	74874	18242	224	3705	215T	T,C,X,IG
5	I	1.0	109789	21873	355	3825	215T	T,C,X,IG

OtN Series

$\diamond$  **Standard Motor Types** (see page B-15 for product codes)

T TEFC, three phase, 208-230/460 or 575 volts

C Corro-Duty®, three phase, 230/460 or 575 volts

X Explosionproof, Cl 1 group D, Cl 2 groups F&G, three phase, 230/460 or 575 volts

IG IntelliGear® variable speed for 3-ph/460V power supplies, NEMA 4/12

$\Delta$  Overhung load rating is at shaft midpoint.

## 15 HP

General Specifications: Totally enclosed, 60 hertz, 40°C ambient, continuous duty.

OtN Series

Output RPM	AGMA Class	Service Factor	Output Torque in - lbs	OHL $\Delta$ lb	Nominal Ratio	Frame Size Gear	Motor	Std. Motor Types $\diamond$
185	III	3+	4815	3659	10	3583	254T	T,C
184	I, II	1.7	4835	2545	10	3473	254T	T,C
142	I, II	1.5	6254	2641	12.5	3473	254T	T,C
142	III	3+	6254	3874	12.5	3583	254T	T,C
117	III	2.6	7576	4022	14	3583	254T	T,C
115	I, II	1.5	7728	2698	14	3473	254T	T,C
113	I, II	1.5	7881	2702	16	3473	254T	T,C
113	III	2.3	7881	4051	16	3583	254T	T,C
100	I	1.3	8898	2720	18	3473	254T	T,C
94	II, III	2.2	9508	4100	18	3583	254T	T,C
88	II, III	2.0	10169	4100	20	3583	254T	T,C
87	I	1.2	10220	2728	20	3473	254T	T,C
82	I	1.1	10830	2726	22.4	3473	254T	T,C
82	II, III	3+	10867	8265	22.4	3693	254T	T,C
74	II	1.8	11999	4100	22.4	3583	254T	T,C
72	I, II	1.7	12355	4100	25	3583	254T	T,C
71	I	1.0	12609	2705	25	3473	254T	T,C
70	III	3.0	12695	8586	25	3693	254T	T,C
65	I, II	1.6	13779	4100	28	3583	254T	T,C
61	III	2.5	14523	8863	28	3693	254T	T,C
57	I, II	1.4	15508	4100	31.5	3583	254T	T,C
56	III	2.3	15945	9052	31.5	3693	254T	T,C
51	I	1.3	17287	4100	35.5	3583	254T	T,C
50	II, III	2.1	17773	9261	35.5	3693	254T	T,C
45	I	1.1	19626	4100	40	3583	254T	T,C
45	II, III	2.0	19906	9489	40	3693	254T	T,C
41	I	1.0	21660	4100	45	3583	254T	T,C
41	III	2.9	21582	14612	45	3703	254T	T,C
40	II	1.7	22394	9709	45	3693	254T	T,C
37	I, II	1.6	24273	9853	50	3693	254T	T,C
37	III	2.7	24222	15056	50	3703	254T	T,C
32	I, II	1.4	27624	10073	56	3693	254T	T,C
31	III	2.8	28386	15687	56	3703	254T	T,C
29	I	1.3	30519	10227	63	3693	254T	T,C
28	II, III	2.2	32093	16170	63	3703	254T	T,C
25	I,	1.1	35343	10429	71	3693	254T	T,C
25	II, III	2.0	34988	16508	71	3703	254T	T,C
23	I	1.0	38542	10530	80	3693	254T	T,C
22	II	1.8	40827	17107	80	3703	254T	T,C
22	III	2.9	40930	16370	80	3823	254T	T,C
21		0.92	43315	10610	90	3693	254T	T,C
20	I, II	1.6	44382	17426	90	3703	254T	T,C
19	III	2.6	46167	16850	90	3823	254T	T,C

$\diamond$  **Standard Motor Types** (see page B-15 for product codes)

T TEFC, three phase, 208-230/460 or 575 volts

C Corro-Duty<sup>®</sup>, three phase, 230/460 or 575 volts

$\Delta$  Overhung load rating is at shaft midpoint.



## 15 HP (Continued)

General Specifications: Totally enclosed, 60 hertz, 40°C ambient, continuous duty.

Output RPM	AGMA Class	Service Factor	Output Torque in - lbs	OHL $\Delta$ lb	Nominal Ratio	Frame Size Gear	Frame Size Motor	Std. Motor Types $\diamond$
18	I, II	1.5	49765	17855	100	3703	254T	T,C
17	III	2.3	51861	17309	100	3823	254T	T,C
16	I	1.3	55350	18241	112	3703	254T	T,C
15	II, III	2.0	58471	17795	112	3823	254T	T,C
14	I	1.2	62460	18242	125	3703	254T	T,C
14	II	1.8	65081	18236	125	3823	254T	T,C
13	I	1.1	68553	18242	140	3703	254T	T,C
13	II	1.7	69657	18507	140	3823	254T	T,C
12	I	1.0	77186	18242	160	3703	254T	T,C
11	II	1.5	78301	18942	160	3823	254T	T,C

$\diamond$  **Standard Motor Types** (see page B-15 for product codes)  
 T TEFC, three phase, 208-230/460 or 575 volts  
 C Corro-Duty®, three phase, 230/460 or 575 volts  
 $\Delta$  Overhung load rating is at shaft midpoint.

## 20 HP

General Specifications: Totally enclosed, 60 hertz, 40°C ambient, continuous duty.

OtN Series

Output RPM	AGMA Class	Service Factor	Output Torque in - lbs	OHL $\Delta$ lb	Nominal Ratio	Frame Size Gear	Motor	Std. Motor Types $\diamond$
185	I, II, III	2.7	6420	3469	10	3583	256T	T,C
142	I, II, III	2.3	8339	3626	12.5	3583	256T	T,C
117	I, II	1.9	10101	3722	14	3583	256T	T,C
113	I, II	1.8	10508	3739	16	3583	256T	T,C
109	III	2.4	10833	7410	16	3693	256T	T,C
98	III	2.3	12120	7610	18	3693	256T	T,C
94	I, II	1.6	12677	3803	18	3583	256T	T,C
88	I, II	1.5	13559	3819	20	3583	256T	T,C
91	III	2.4	13000	7734	20	3693	256T	T,C
82	II, III	2.4	14489	7923	22.4	3693	256T	T,C
74	I	1.3	15999	3837	22.4	3583	256T	T,C
72	I	1.3	16474	3837	25	3583	256T	T,C
70	II, III	2.2	16927	8187	25	3693	256T	T,C
65	III	3.1	18213	12568	28	3703	256T	T,C
65	I	1.2	18372	3826	28	3583	256T	T,C
61	II	1.5	19364	8406	28	3693	256T	T,C
58	III	2.7	20583	12981	31.5	3703	256T	T,C
57	I	1.1	20677	3793	31.5	3583	256T	T,C
56	II	1.8	21260	8551	31.5	3693	256T	T,C
51	III	2.5	23020	13401	35.5	3703	256T	T,C
50	I, II	1.6	23697	8709	35.5	3693	256T	T,C
46	III	2.3	25796	13749	40	3703	256T	T,C
45	I, II	1.5	26541	8862	40	3693	256T	T,C
41	II, III	2.2	28775	14121	45	3703	256T	T,C
40	I	1.3	29859	9004	45	3693	256T	T,C
37	I	1.2	32364	9090	50	3693	256T	T,C
37	II, III	2.0	32296	14512	50	3703	256T	T,C
32	I	1.1	36833	9203	56	3693	256T	T,C
31	II, III	2.1	37848	15041	56	3703	256T	T,C
29	I	1.0	40692	8210	63	3693	256T	T,C
28	II	1.6	42791	15440	63	3703	256T	T,C
27	III	2.7	43591	15130	63	3823	256T	T,C
25	I, II	1.5	46650	15713	71	3703	256T	T,C
24	III	2.4	48946	15537	71	3823	256T	T,C
22	I	1.3	54436	16179	80	3703	256T	T,C
22	II, III	2.2	54573	15925	80	3823	256T	T,C
20	I	1.2	59176	16416	90	3703	256T	T,C
19	II	1.9	61556	16349	90	3823	256T	T,C
18	I	1.1	66353	16723	100	3703	256T	T,C
17	II	1.7	69149	16746	100	3823	256T	T,C
16	I	1.0	73800	16800	112	3703	256T	T,C
15	II	1.5	77962	17160	112	3823	256T	T,C
14	I, II	1.4	86775	17528	125	3823	256T	T,C
13	I	1.3	92876	17748	140	3823	256T	T,C
11	I	1.1	104401	18095	160	3823	256T	T,C

$\diamond$  Standard Motor Types (see page B-15 for product codes)  $\Delta$  Overhung load rating is at shaft midpoint.  
 T TEFC, three phase, 208-230/460 or 575 volts  
 C Corro-Duty®, three phase, 230/460 or 575 volts

## 25 HP

General Specifications: Totally enclosed, 60 hertz, 40°C ambient, continuous duty.

Output RPM	AGMA Class	Service Factor	Output Torque in - lbs	OHL Δ lb	Nominal Ratio	Frame Size Gear	Motor	Std. Motor Types ◇	Special Note(s)
185	I, II, III	2.2	8025	3278	10	3583	284T	T,C	TL
161	I, II, III	2.4	9225	6549	11.2	3693	284T	T,C	
142	I, II	1.8	10423	3379	12.5	3583	284T	T,C	TL
138	III	2.2	10748	6793	12.5	3693	284T	T,C	
120	III	2.1	12357	7012	14	3693	284T	T,C	
117	I, II	1.5	12626	3422	14	3583	284T	T,C	TL
113	I, II	1.4	13135	3427	16	3583	284T	T,C	TL
113	III	2.9	13118	10592	16	3703	284T	T,C	
109	II	1.9	13541	7154	16	3693	284T	T,C	
99	III	2.8	14896	10172	18	3703	284T	T,C	
98	II	1.9	15149	7324	18	3693	284T	T,C	
94	I	1.3	15847	3427	18	3583	284T	T,C	TL
91	II	1.9	16250	7427	20	3693	284T	T,C	
88	I	1.2	16948	3416	20	3583	284T	T,C	TL
88	III	2.8	16842	11341	20	3703	284T	T,C	
82	II	1.9	18112	7581	22.4	3693	284T	T,C	
77	III	2.8	19127	11726	22.4	3703	284T	T,C	
74	I	1.1	19999	3362	22.4	3583	284T	T,C	
73	III	2.8	20312	11909	25	3703	284T	T,C	
72	I	1.0	20592	3347	25	3583	284T	T,C	
70	II	1.8	21158	7788	25	3693	284T	T,C	
65	III	2.4	22766	12287	28	3703	284T	T,C	
61	I, II	1.5	24205	7949	28	3693	284T	T,C	
58	III	2.2	25729	12630	31.5	3703	284T	T,C	
56	I, II	1.4	26575	8049	31.5	3693	284T	T,C	
51	II, III	2.0	28775	13004	35.5	3703	284T	T,C	
50	I	1.3	29622	8150	35.5	3693	284T	T,C	
46	II	1.9	32245	13309	40	3703	284T	T,C	
45	I	1.2	33176	8236	40	3693	284T	T,C	
43	III	3.5	34405	13292	40	3823	284T	T,C	
41	II, III	1.7	35969	13631	45	3703	284T	T,C	
40	I	1.0	37323	8300	45	3693	284T	T,C	
38	II, III	3.2	38811	13679	45	3823	284T	T,C	
37	I	1.0	40455	8410	50	3693	284T	T,C	
37	II	1.6	40370	13961	50	3703	284T	T,C	
35	III	2.8	42455	13974	50	3823	284T	T,C	
31	I, II	1.7	47310	14395	56	3703	284T	T,C	
31	III	2.5	48302	14388	56	3823	284T	T,C	
28	I	1.3	53488	14710	63	3703	284T	T,C	
27	II, III	2.2	54488	14775	63	3823	284T	T,C	
25	I	1.2	58313	14171	71	3703	284T	T,C	
24	I, III	2.0	61183	15138	71	3823	284T	T,C	
22	I	1.1	68045	15250	80	3703	284T	T,C	
22	II	1.8	68216	15481	80	3823	284T	T,C	
20	I	1.0	73970	15250	90	3703	284T	T,C	
19	II	1.6	76945	15848	90	3823	284T	T,C	
17	II	1.4	86436	16184	100	3823	284T	T,C	
17	I	1.0	86411	15250	100	3703	284T	T,C	
15	I	1.2	97452	16526	112	3823	284T	T,C	
14	I	1.1	108468	16819	125	3823	284T	T,C	
13	I	1.0	116095	16989	140	3823	284T	T,C	

◇ Standard Motor Types (see page B-15 for product codes)

T TEFC, three phase, 208-230/460 or 575 volts  
C Corro-Duty®, three phase, 230/460 or 575 volts

Δ Overhung load rating is at shaft midpoint.

TL Denotes a selection of HP/gear frame where thermal limits may restrict this selection based on mounting position. See table on B-144

## 30 HP

General Specifications: Totally enclosed, 60 hertz, 40°C ambient, continuous duty.

OtN Series

Output RPM	AGMA Class	Service Factor	Output Torque in - lbs	OHL $\Delta$ lb	Nominal Ratio	Frame Size Gear	Motor	Std. Motor Types $\diamond$	Special Note(s)
185	I, II	1.8	9618	3278	10	3583	286T	T,C	TL
178	III	2.2	9963	6223	10	3693	286T	T,C	TL
161	III	2.0	11070	6375	11.2	3693	286T	T,C	TL
142	I, II	1.5	12492	3379	12.5	3583	286T	T,C	TL
142	III	2.7	12492	9787	12.5	3703	286T	T,C	
138	II	1.9	12898	6590	12.5	3693	286T	T,C	
128	III	2.4	13914	10079	14	3703	286T	T,C	
120	II	1.7	14828	6779	14	3693	286T	T,C	
117	I	1.3	15191	3422	14	3583	286T	T,C	TL
113	I	1.2	15728	3427	16	3583	286T	T,C	TL
113	III	2.4	15742	10418	16	3703	286T	T,C	
109	II	1.6	16250	6898	16	3693	286T	T,C	
99	III	2.3	17875	10770	18	3703	286T	T,C	
98	II	1.6	18179	7038	18	3693	286T	T,C	
94	I	1.1	18908	3427	18	3583	286T	T,C	TL
91	II	1.6	19524	7120	20	3693	286T	T,C	
88	I	1.0	20197	3416	20	3583	286T	T,C	TL
88	III	2.3	20236	11111	20	3703	286T	T,C	
82	I, II	1.6	21761	7239	22.4	3693	286T	T,C	
77	III	2.3	22982	11465	22.4	3703	286T	T,C	
73	III	2.3	24405	11623	25	3703	286T	T,C	
70	I, II	1.5	25422	7388	25	3693	286T	T,C	
65	II, III	2.0	27320	11976	28	3703	286T	T,C	
61	I	1.2	29046	7492	28	3693	286T	T,C	
58	II	1.8	30874	12278	31.5	3703	286T	T,C	
56	I	1.2	31890	7547	31.5	3693	286T	T,C	
54	III	3.4	32947	12252	31.5	3823	286T	T,C	
51	II	1.7	34530	12606	35.5	3703	286T	T,C	
50	I	1.1	35546	7591	35.5	3693	286T	T,C	
48	III	3+	37015	12656	35.5	3823	286T	T,C	
46	II	1.6	38694	12869	40	3703	286T	T,C	
45	III	3.0	39557	12947	40	3823	286T	T,C	
45	I	1.0	39812	7600	40	3693	286T	T,C	
41	I, II	1.5	43163	13140	45	3703	286T	T,C	
40	III	2.6	44947	13321	45	3823	286T	T,C	
37	I, II	1.4	48444	13410	50	3703	286T	T,C	
35	III	2.3	50946	13698	50	3823	286T	T,C	
31	I	1.2	56772	13750	56	3703	286T	T,C	
31	II, III	2.1	57963	14073	56	3823	286T	T,C	
28	I	1.1	64186	13970	63	3703	286T	T,C	
27	II	1.8	65386	14420	63	3823	286T	T,C	
25	I	1.0	69975	14121	71	3703	286T	T,C	
24	II	1.6	73420	14740	71	3823	286T	T,C	
22	I, II	1.5	81860	15036	80	3823	286T	T,C	
19	I	1.3	92334	15346	90	3823	286T	T,C	
17	I	1.2	103723	15622	100	3823	286T	T,C	
15	I	1.0	116942	15891	112	3823	286T	T,C	

$\diamond$  **Standard Motor Types** (see page B-15 for product codes)

T TEFC, three phase, 208-230/460 or 575 volts

C Corro-Duty<sup>®</sup>, three phase, 230/460 or 575 volts

$\Delta$  Overhung load rating is at shaft midpoint.

TL Denotes a selection of HP/gear frame where thermal limits may restrict this selection based on mounting position. See table on B-144

## 40 HP

General Specifications: Totally enclosed, 60 hertz, 40°C ambient, continuous duty.

Output RPM	AGMA Class	Service Factor	Output Torque in - lbs	OHL $\Delta$ lb	Nominal Ratio	Frame Size Gear	Motor	Std. Motor Types $\diamond$	Special Note(s)
178	I, II	1.6	13284	5910	10	3693	324T	T,C	TL
173	III	2.3	13677	9100	10	3703	324T	T,C	TL
161	I, II	1.5	14760	6026	11.2	3693	324T	T,C	TL
152	III	2.1	15573	9314	11.2	3703	324T	T,C	TL
142	III	2.1	16656	9503	12.5	3703	324T	T,C	TL
138	I, II	1.4	17198	6184	12.5	3693	324T	T,C	TL
128	II	1.8	18552	9763	14	3703	324T	T,C	TL
120	I	1.3	19770	6313	14	3693	324T	T,C	TL
113	II	1.8	20989	10060	16	3703	324T	T,C	TL
109	I	1.2	21666	6387	16	3693	324T	T,C	TL
99	II	1.7	23833	10363	18	3703	324T	T,C	
98	I	1.1	24239	6466	18	3693	324T	T,C	TL
91	I	1.2	26032	6506	20	3693	324T	T,C	TL
88	II	1.8	26947	10652	20	3703	324T	T,C	
82	I	1.2	29015	6555	22.4	3693	324T	T,C	TL
79	III	3.0	30100	11052	22.4	3823	324T	T,C	
77	II	1.8	30603	10943	22.4	3703	324T	T,C	
73	II	1.7	32499	11078	25	3703	324T	T,C	
70	I	1.1	33896	6589	25	3693	324T	T,C	TL
69	III	3.0	34303	11387	25	3823	324T	T,C	
65	I, II	1.5	36426	11375	28	3703	324T	T,C	
61	III	2.7	38913	11726	28	3823	324T	T,C	
58	I, II	1.4	41166	11576	31.5	3703	324T	T,C	
54	III	2.6	43930	12042	31.5	3823	324T	T,C	
51	I	1.3	46041	11812	35.5	3703	324T	T,C	
48	II, III	2.3	49353	12340	35.5	3823	324T	T,C	
46	I	1.2	51593	11989	40	3703	324T	T,C	
43	II, III	2.2	55048	12621	40	3823	324T	T,C	
41	I	1.1	57551	11670	45	3703	324T	T,C	
38	II, III	2.0	62098	12922	45	3823	324T	T,C	
37	I	1.0	64592	12308	50	3703	324T	T,C	
35	II	1.8	67928	13144	50	3823	324T	T,C	
31		0.91	75696	12410	56	3703	324T	T,C	
31	I, II	1.5	77284	13444	56	3823	324T	T,C	
27	I, II	1.4	87181	13709	63	3823	324T	T,C	
24	I	1.2	97893	13943	71	3823	324T	T,C	
22	I	1.1	109146	14147	80	3823	324T	T,C	

OtN Series

$\diamond$  **Standard Motor Types** (see page B-15 for product codes)

T TEFC, three phase, 230/460 or 575 volts

C Corro-Duty®, three phase, 230/460 or 575 volts

$\Delta$  Overhung load rating is at shaft midpoint.

TL Denotes a selection of HP/gear frame where thermal limits may restrict this selection based on mounting position. See table on B-144

## 50 HP

General Specifications: Totally enclosed, 60 hertz, 40°C ambient, continuous duty.

OtN Series

Output RPM	AGMA Class	Service Factor	Output Torque in - lbs	OHL $\Delta$ lb	Nominal Ratio	Frame Size Gear	Motor	Std. Motor Types $\diamond$	Special Note(s)
128	I, II	1.4	23219	9446	14	3703	326T	T,C	TL
113	I, II	1.4	26270	9702	16	3703	326T	T,C	TL
99	I, II	1.4	29829	9957	18	3703	326T	T,C	TL
88	I, II	1.4	33727	10192	20	3703	326T	T,C	TL
79	III	2.4	37625	10807	22.4	3823	326T	T,C	
77	I, II	1.4	38303	10421	22.4	3703	326T	T,C	TL
73	I, II	1.4	40676	10523	25	3703	326T	T,C	TL
69	III	2.4	42879	11109	25	3823	326T	T,C	
65	I	1.2	45533	10704	28	3703	326T	T,C	
61	II, III	2.1	48641	11409	28	3823	326T	T,C	
58	I	1.1	51457	10874	31.5	3703	326T	T,C	
54	II, III	2.1	54912	11685	31.5	3823	326T	T,C	
51	I	1.0	57551	11012	35.5	3703	326T	T,C	
48	II	1.8	61691	11939	35.5	3823	326T	T,C	
46		0.94	64491	11158	40	3703	326T	T,C	
43	I, II	1.7	68810	12173	40	3823	326T	T,C	
41		0.87	71939	11350	45	3703	326T	T,C	
38	I, II	1.6	77623	12416	45	3823	326T	T,C	
35	I, II	1.4	84910	12814	50	3823	326T	T,C	
31	I	1.2	96605	12999	56	3823	326T	T,C	
27	I	1.1	108977	13147	63	3823	326T	T,C	
24		0.98	122366	13258	71	3823	326T	T,C	

$\diamond$  **Standard Motor Types** (see page B-15 for product codes)

T TEFC, three phase, 230/460 or 575 volts

C Corro-Duty<sup>®</sup>, three phase, 230/460 or 575 volts

$\Delta$  Overhung load rating is at shaft midpoint.

TL Denotes a selection of HP/gear frame where thermal limits may restrict this selection based on mounting position. See table on B-144



## 2-Stage Output Shafted Foot Mount OtN31 - 32

Standard conduit box location will be opposite shaft extension unless specified otherwise.

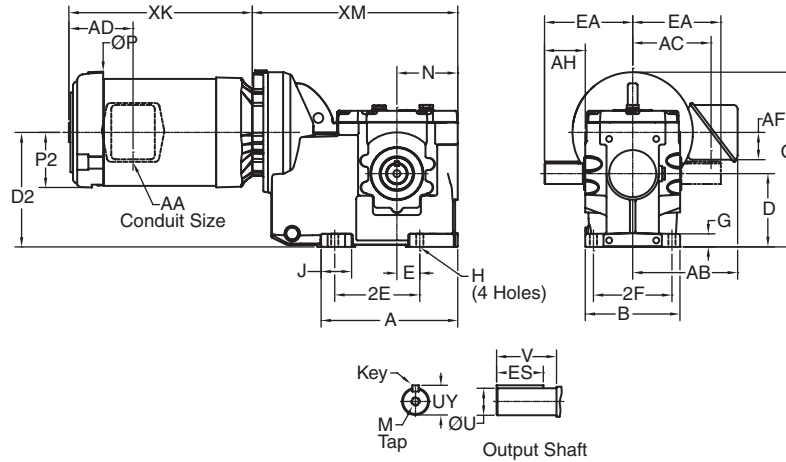

OtN Series

Gear Frame	Version	A	B	D <sup>1</sup>	D <sub>2</sub>	E	2E	2F	G	H	J	O	N	XM
3132	S2	5.88	4.65	3.15	4.98	1.97	3.94	3.94	.56	.35	1.53	8.01	3.15	10.59
3242	S2	8.22	5.71	4.41	6.89	1.38	5.12	4.72	.79	.43	1.83	10.51	3.66	12.36

### Output Shaft

Gear Frame	Version	U <sup>3</sup>	UY	V	AH	EA	Key	ES	M
3132	S2	1.000	1.10	1.77	1.83	4.33	1/4 Sq.	1.34	3/8-16 X .87
3242	S2	1.250	1.35	2.38	2.45	5.31	1/4 Sq.	2.03	1/2-13 X 1.12

Motor Frame	Motor Type <sup>4</sup>	Gear Frame	P	P <sub>2</sub>	AA	AB	AC	AD	AF	XK
56	T	Any	7.31	3.31	.75	6.10	4.50	3.86	1.77	9.79
B56	T	Any	7.31	3.31	.75	6.10	4.50	3.86	1.77	11.04
143T, 145T	T	Any	7.31	3.31	.75	6.10	4.50	3.86	1.77	11.04
182T/184T	T	Any	9.56	4.34	.75	6.10	4.50	5.13	1.77	14.04
213T	T	32	11.25	5.06	1.00	8.42	7.17	5.60	2.42	16.15
215T	T	32	11.25	5.06	1.00	8.42	7.17	5.60	2.42	17.65

<sup>1</sup> Dimension "D" will never be exceeded, but may vary from values shown. When exact dimensions are required, shims up to .03" may be necessary.

<sup>2</sup> All rough casting dimensions may vary by .25" due to casting variations.

<sup>3</sup> Shaft extension tolerances: +.0000"; -.0005" for shafts up to 1.5" diameter "U". Larger diameter: "U", +.000"; -.001".

<sup>4</sup> Motor dimensions for other than "Type T" three phase TEFC motors, refer to pages B-114 to B-116.

## 3-Stage Output Shafted Foot Mount OtN32 - 33

Standard conduit box location will be opposite shaft extension unless specified otherwise.

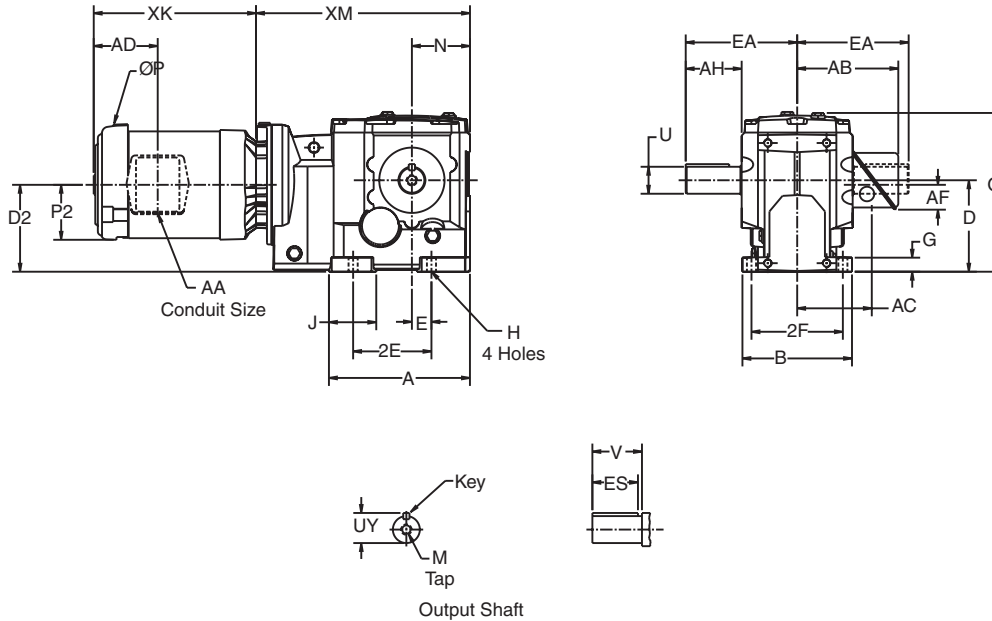

Gear Frame	Version	A	B	D <sup>1</sup>	D2	E	2E	2F	G	H	J	O	N	XM
32	S2	7.81	5.71	4.41	3.78	1.38	5.12	4.72	.73	.43	2.34	8.09	3.03	10.98
	S1	8.08	5.88	4.92	4.20	3.35	6.69	6.10	.79	.55	2.27	10.43	3.54	12.90
33	S2	8.50	6.61	5.51	5.24	1.18	4.72	5.51	.85	.55	2.86	9.69	3.54	12.90
	S1	8.08	6.58	4.92	5.20	3.35	6.69	6.10	.79	.55	2.27	10.43	3.54	12.90

### Output Shaft

Gear Frame	Version	U <sup>3</sup>	UY	V	AH	EA	Key	ES	M
32	S2	1.250	1.354	2.36	2.46	5.31	1/4 Sq.	2.06	1/2-13 x 1.12
	S1	1.625	1.783	3.25	3.39	6.73	3/8 Sq.	2.78	5/8-11 x 1.38
33	S2	1.500	1.657	3.18	3.19	7.12	3/8 Sq.	2.78	5/8-11 x 1.38
	S1	1.500	1.657	3.18	3.19	7.12	3/8 Sq.	2.78	5/8-11 x 1.38

Motor Frame	Motor Type <sup>4</sup>	Gear Frame	P	P2	AA	AB	AC	AD	AF	XK
56	T	Any	7.31	3.31	.75	6.10	4.50	3.86	1.77	9.79
B56	T	Any	7.31	3.31	.75	6.10	4.50	3.86	1.77	11.04
143T, 145T	T	Any	7.31	3.31	.75	6.10	4.50	3.86	1.77	11.04
182T/184T	T	Any	9.56	4.34	.75	6.10	4.50	5.13	1.77	14.04
213T	T	32	11.25	5.06	1.00	8.42	7.17	5.60	2.42	16.15
215T	T	32	11.25	5.06	1.00	8.42	7.17	5.60	2.42	17.65

<sup>1</sup> Dimension "D" will never be exceeded, but may vary from values shown. When exact dimensions are required, shims up to .03" may be necessary.

<sup>2</sup> All rough casting dimensions may vary by .25" due to casting variations.

<sup>3</sup> Shaft extension tolerances: +.0000"; -.0005" for shafts up to 1.5" diameter "U". Larger diameter: "U", +.000"; -.001".

<sup>4</sup> Motor dimensions for other than "Type T" three phase TEFC motors, refer to pages B-114 to B-116.

## 3-Stage Output Shafted Foot Mount OtN34 - 35

Standard conduit box location will be opposite shaft extension unless specified otherwise.

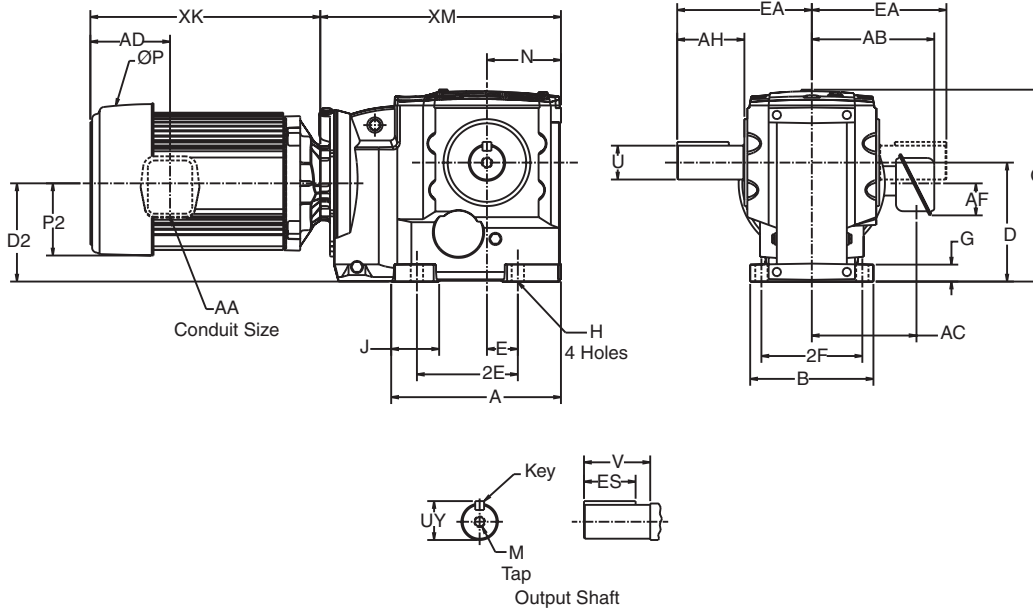

OtN Series

Gear Frame	Version	A	B	D <sup>1</sup>	D <sub>2</sub>	E	2E	2F	G	H	J	O	N	XM	
														56T-215T	254T-286T
34	S2	10.13	7.87	7.09	5.90	1.57	5.91	6.50	1.07	.71	2.67	12.05	4.49	14.56	-
	S1	10.69	9.60	6.30	7.49	4.53	9.06	7.68	1.18	.71	3.19	13.39	4.49		
35	S2	11.92	8.66	8.35	6.89	2.17	7.09	7.09	1.18	.87	3.37	13.58	5.20	16.90	17.25
	S1	13.07	10.98	7.87	9.33	5.51	11.02	9.06	1.40	.87	4.05	16.22	5.20		

### Output Shaft

Gear Frame	Version	U <sup>3</sup>	UY	V	AH	EA	Key	ES	M
34	S2	2.000	2.21	3.63	3.76	8.11	1/2 Sq.	3.06	3/4-10 X 1.61
	S1	1.750	1.909	3.56	3.66	8.46	3/8 Sq.	3.56	3/4-10 X 1.61
35	S2	2.375	2.638	4.61	4.74	9.45	5/8 Sq.	3.81	3/4-10 X 1.61
	S1	2.375	2.638	5.73	5.27	10.57	5/8 Sq.	4.81	3/4-10 X 1.61

Motor Frame	Motor Type <sup>4</sup>	Gear Frame	P	P <sub>2</sub>	AA	AB	AC	AD	AF	XK
56	T	Any	7.31	3.31	.75	6.10	4.50	3.86	1.77	9.79
B56	T	Any	7.31	3.31	.75	6.10	4.50	3.86	1.77	11.04
143T, 145T	T	Any	7.31	3.31	.75	6.10	4.50	3.86	1.77	11.04
182T/184T	T	Any	9.56	4.34	.75	6.10	4.50	5.13	1.77	14.04
213T	T	Any	11.25	5.06	1.00	8.42	7.17	5.60	2.42	16.15
215T	T	Any	11.25	5.06	1.00	8.42	7.17	5.60	2.42	17.65
254T	T	34	13.38	6.00	1.25	9.79	7.68	8.29	1.81	20.58
	T	35	13.38	6.00	1.25	9.79	7.68	8.29	1.81	19.61
256T	T	34	13.38	6.00	1.25	9.79	7.68	8.29	1.81	22.33
	T	35	13.38	6.00	1.25	9.79	7.68	8.29	1.81	21.36
284T/286T	T	35	14.62	7.29	1.50	11.33	8.51	12.44	2.63	24.26

<sup>1</sup> Dimension "D" will never be exceeded, but may vary from values shown. When exact dimensions are required, shims up to .03" may be necessary.

<sup>2</sup> All rough casting dimensions may vary by .25" due to casting variations.

<sup>3</sup> Shaft extension tolerances: +.0000"; -.0005" for shafts up to 1.5" diameter "U". Larger diameter: "U", +.000"; -.001".

<sup>4</sup> Motor dimensions for other than "Type T" three phase TEFC motors, refer to pages B-114 to B-116.

## 3-Stage Output Shafted Foot Mount OtN36-38

Standard conduit box location will be opposite shaft extension unless specified otherwise.

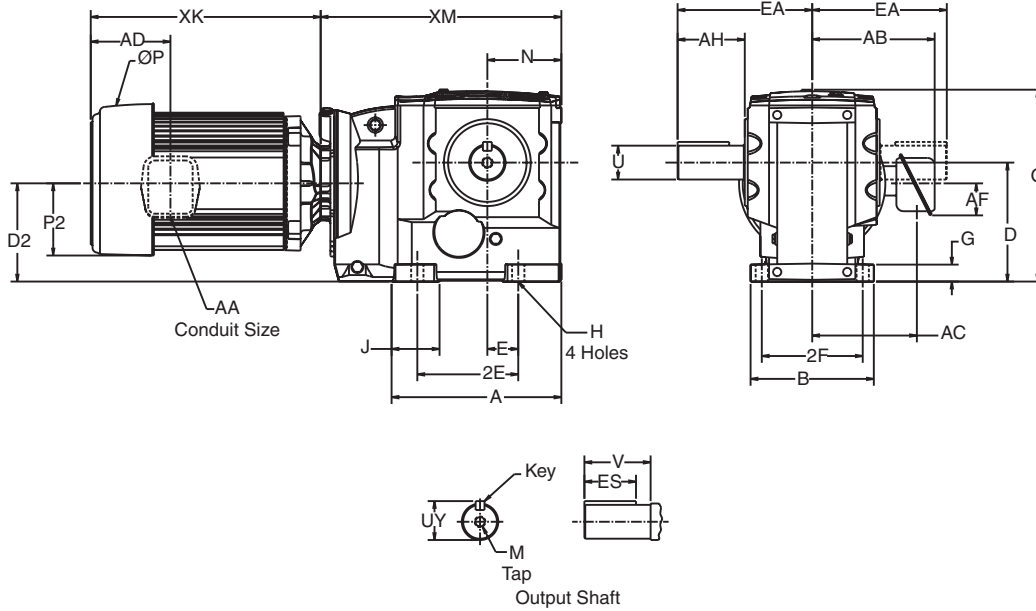

OtN Series

Gear Frame	Version	A	B	D <sup>1</sup>	D2	E	2E	2F	G	H	J	O	N	XM		
														182T/184T	213T-215T	254T-UP
36	S1	17.06	11.41	8.86	8.86	6.99	13.98	9.45	1.57	.87	3.87	16.26	8.74	23.38	23.38	23.73
37	S1	20.58	12.99	9.84	10.98	8.27	16.54	10.63	1.93	.94	4.78	18.29	10.04	-	29.06	29.41
38	S2	17.85	13.39	14.76	11.87	4.53	13.78	10.63	1.98	1.26	4.06	24.11	8.86	-	24.29	24.64

### Output Shaft

Gear Frame	Version	U <sup>3</sup>	UY	V	AH	EA	Key	ES	M
36	S1	2.875	3.200	5.75	5.92	11.94	3/4 SQ.	5.00	3/4-10 X 1.61
37	S1	3.625	4.010	6.86	7.04	13.66	7/8 SQ.	6.00	1-8 X 2.13
38	S2	4.375	4.809	8.99	9.97	17.03	1.00 SQ.	7.00	1-8 X 2.25

Motor Frame	Motor Type <sup>4</sup>	Gear Frame	P	P2	AA	AB	AC	AD	AF	XK
182T/184T	T	36	9.56	4.34	.75	6.10	4.50	5.13	1.77	14.04
213T	T	All	11.25	5.06	1.00	8.42	7.17	5.60	2.42	16.15
215T	T	All	11.25	5.06	1.00	8.42	7.17	5.60	2.42	17.65
254T	T	All	13.38	6.00	1.25	9.79	7.68	8.29	1.81	19.61
256T	T	All	13.38	6.00	1.25	9.79	7.68	8.29	1.81	21.36
284T/286T	T	All	14.62	7.29	1.50	11.33	8.51	12.44	2.63	24.26
324T/326T	T	All	17.20	7.78	2.00	14.99	11.34	14.16	3.63	27.36

<sup>1</sup> Dimension "D" will never be exceeded, but may vary from values shown. When exact dimensions are required, shims up to .03" may be necessary.

<sup>2</sup> All rough casting dimensions may vary by .25" due to casting variations.

<sup>3</sup> Shaft extension tolerances: +.0000"; -.0005" for shafts up to 1.5" diameter "U". Larger diameter: "U", +.000"; -.001".

<sup>4</sup> Motor dimensions for other than "Type T" three phase TEFC motors, refer to pages B-114 to B-116.

## Combined Output Shafted Foot Mount OtN32 - 33

Standard conduit box location will be opposite shaft extension unless specified otherwise.

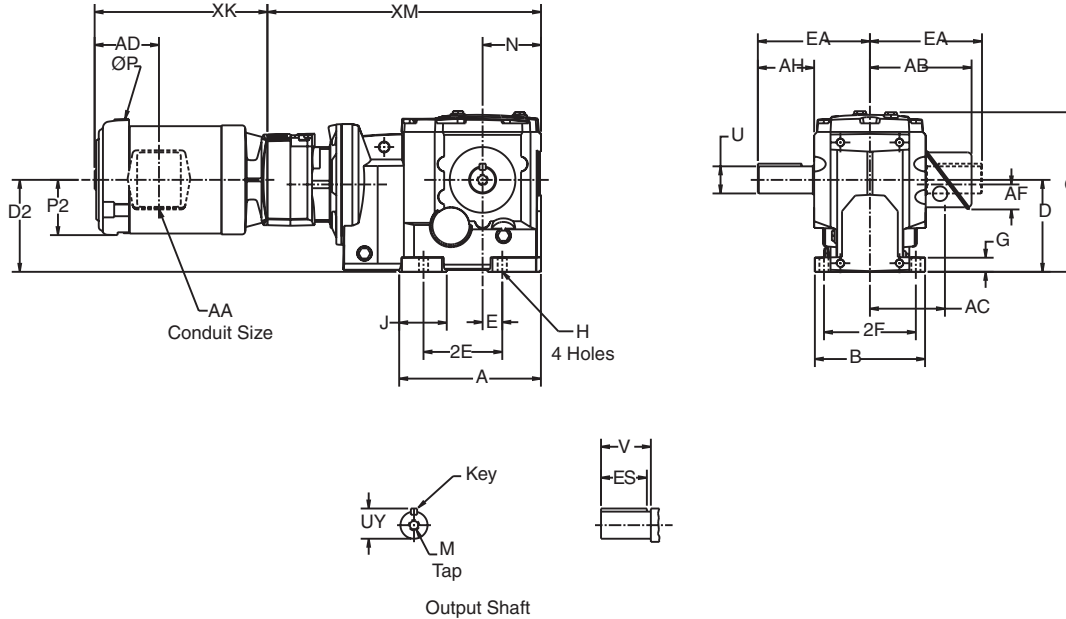

OtN Series

Gear Frame	Version	A	B	D <sup>1</sup>	D <sub>2</sub>	E	2E	2F	G	H	J	O	N	XM
32	S2	7.81	5.71	4.41	4.06	1.38	5.12	4.72	.73	.43	2.34	8.09	3.03	14.49
33	S2	8.50	6.61	5.51	4.91	1.18	4.72	5.51	.85	.55	2.86	9.69	3.54	19.90
	S1	8.08	8.58	4.92	4.87	3.35	6.69	6.10	.79	.55	2.27	10.43	3.54	19.90

### Output Shaft

Gear Frame	Version	U <sup>3</sup>	UY	V	AH	EA	Key	ES	M
32	S2	1.250	1.354	2.36	2.46	5.31	1/4 Sq.	2.06	1/2-13 X 1.12
33	S2	1.625	1.783	3.25	3.39	6.73	3/8 Sq.	2.78	5/8-11 X 1.38
	S1	1.500	1.657	3.18	3.19	7.12	3/8 Sq.	2.78	5/8-11 X 1.38

Motor Frame	Motor Type <sup>4</sup>	Gear Frame	P	P <sub>2</sub>	AA	AB	AC	AD	AF	XK
56	T	32	7.31	3.31	.75	6.10	4.50	3.86	1.77	10.37
	T	33	7.31	3.31	.75	6.10	4.50	3.86	1.77	9.79
B56	T	32	7.31	3.31	.75	6.10	4.50	3.86	1.77	11.62
	T	33	7.31	3.31	.75	6.10	4.50	3.86	1.77	11.04
143T, 145T	T	32	7.31	3.31	.75	6.10	4.50	3.86	1.77	11.04

<sup>1</sup> Dimension "D" will never be exceeded, but may vary from values shown. When exact dimensions are required, shims up to .03" may be necessary.

<sup>2</sup> All rough casting dimensions may vary by .25" due to casting variations.

<sup>3</sup> Shaft extension tolerances: +.0000"; -.0005" for shafts up to 1.5" diameter "U". Larger diameter: "U", +.000"; -.001".

<sup>4</sup> Motor dimensions for other than "Type T" three phase TEFC motors, refer to pages B-114 to B-116.

## Combined Output Shafted Foot Mount OtN34 - 35

Standard conduit box location will be opposite shaft extension unless specified otherwise.

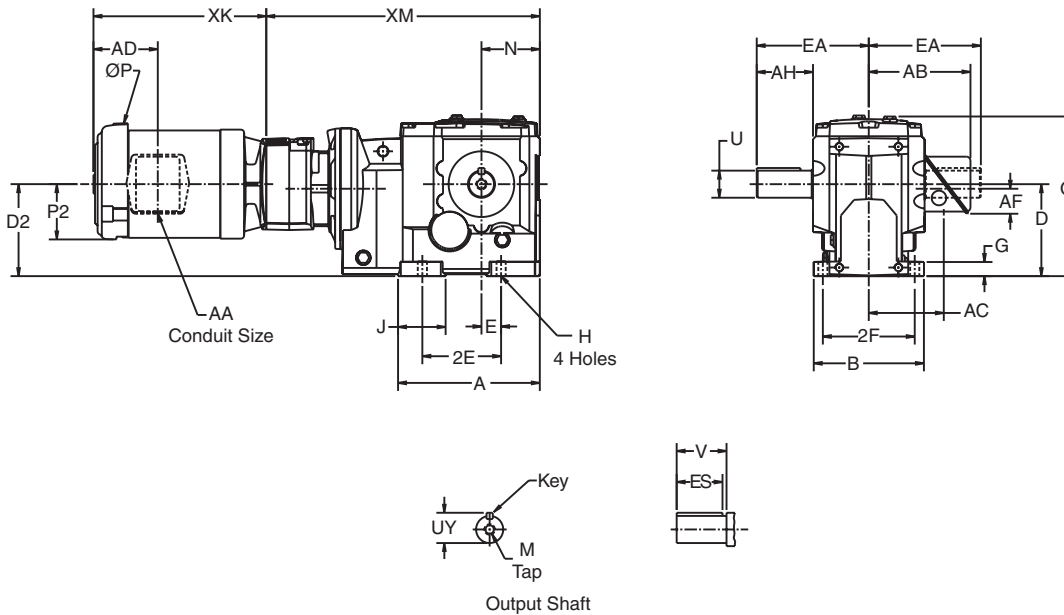

Output Shaft

Gear Frame	Version	A	B	D <sup>1</sup>	D2	E	2E	2F	G	H	J	O	N	XM
34	S2	10.13	7.87	7.09	5.57	1.57	5.91	6.50	1.07	.71	2.67	12.05	4.49	21.55
	S1	10.69	9.60	6.30	7.16	4.53	9.06	7.68	1.18	.71	3.19	13.39	4.49	21.55
35	S2	11.92	8.66	8.35	6.56	2.17	7.09	7.09	1.18	.87	3.37	13.58	5.20	23.87
	S1	13.07	10.98	7.87	9.00	5.51	11.02	9.06	1.40	.87	4.05	16.22	5.20	23.87

### Output Shaft

Gear Frame	Version	U <sup>3</sup>	UY	V	AH	EA	Key	ES	M
34	S2	2.000	2.21	3.63	3.76	8.11	1/2 Sq.	3.06	3/4-10 X 1.61
	S1	1.750	1.909	3.56	3.66	8.46	3/8 Sq.	3.56	3/4-10 X 1.61
35	S2	2.375	2.638	4.61	4.74	9.45	5/8 Sq.	3.81	3/4-10 X 1.61
	S1	2.375	2.638	5.73	5.27	10.57	5/8 Sq.	4.81	3/4-10 X 1.61

Motor Frame	Motor Type <sup>4</sup>	Gear Frame	P	P2	AA	AB	AC	AD	AF	XK
56	T	Any	7.31	3.31	.75	6.10	4.50	3.86	1.77	9.79
B56	T	Any	7.31	3.31	.75	6.10	4.50	3.86	1.77	11.04
143T, 145T	T	Any	7.31	3.31	.75	6.10	4.50	3.86	1.77	11.04
182T/184T	T	35	9.56	4.34	.75	6.10	4.50	5.13	1.77	14.04

<sup>1</sup> Dimension "D" will never be exceeded, but may vary from values shown. When exact dimensions are required, shims up to .03" may be necessary.

<sup>2</sup> All rough casting dimensions may vary by .25" due to casting variations.

<sup>3</sup> Shaft extension tolerances: +.0000"; -.0005" for shafts up to 1.5" diameter "U". Larger diameter: "U", +.000"; -.001".

<sup>4</sup> Motor dimensions for other than "Type T" three phase TEFC motors, refer to pages B-114 to B-116.



## Combined Output Shafted Foot Mount OtN36 - 38

Standard conduit box location will be opposite shaft extension unless specified otherwise.

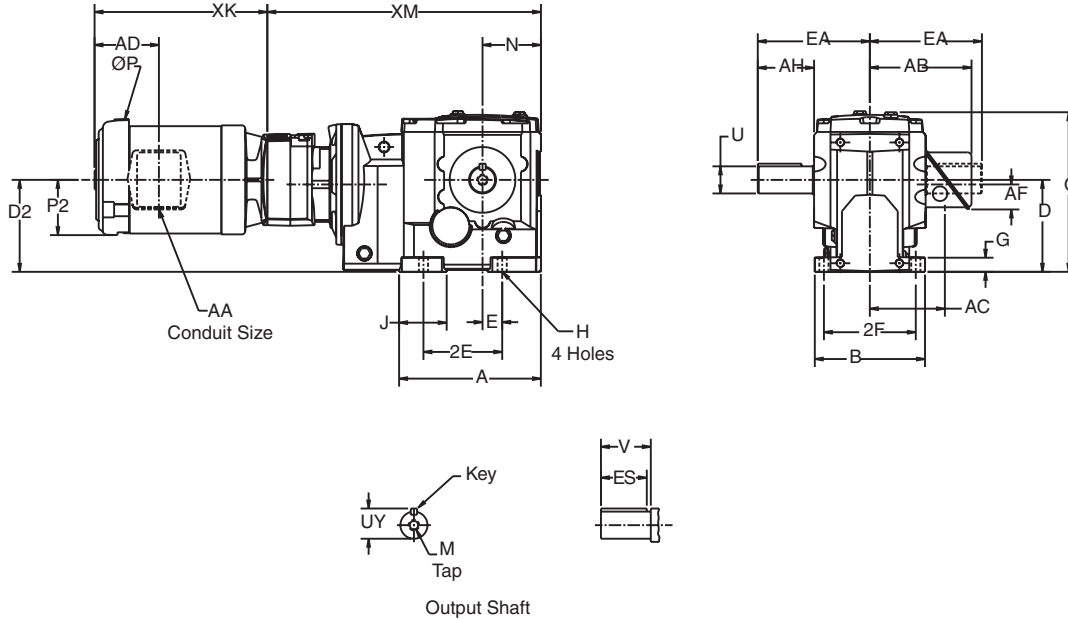

OtN Series

Gear Frame	Version	A	B	D <sup>1</sup>	D2	E	2E	2F	G	H	J	O	N	XM
														56 -215T
36	S1	17.06	11.41	8.86	8.46	6.99	13.98	9.45	1.57	.87	3.87	16.26	8.74	31.04
37	S1	20.58	12.99	9.84	10.57	8.27	16.54	10.63	1.93	.94	4.78	18.29	10.04	36.37
38	S2	17.85	13.39	14.76	11.48	4.53	13.78	10.63	1.98	1.26	4.06	24.11	8.86	31.94

### Output Shaft

Gear Frame	Version	U <sup>3</sup>	UY	V	AH	EA	Key	ES	M
36	S1	2.875	3.20	5.75	5.92	11.94	3/4 SQ.	5.00	3/4-10 X 1.61
37	S1	3.625	4.01	6.86	7.04	13.66	7/8 SQ.	6.00	1-8 X 2.13
38	S2	4.375	4.809	8.99	9.97	17.03	1.00 SQ.	7.00	1-8 X 2.25

Motor Frame	Motor Type <sup>4</sup>	Gear Frame	P	P2	AA	AB	AC	AD	AF	XK
56	T	All	7.31	3.31	.75	6.10	4.50	3.86	1.77	9.79
B56	T	All	7.31	3.31	.75	6.10	4.50	3.86	1.77	11.04
143T, 145T	T	All	7.31	3.31	.75	6.10	4.50	3.86	1.77	11.04
182T/184T	T	All	9.56	4.34	.75	6.10	4.50	5.13	1.77	14.04
213T	T	All	11.25	5.06	1.00	8.42	7.17	5.60	2.42	16.15
215T	T	All	11.25	5.06	1.00	8.42	7.17	5.60	2.42	17.65

<sup>1</sup> Dimension "D" will never be exceeded, but may vary from values shown. When exact dimensions are required, shims up to .03" may be necessary.

<sup>2</sup> All rough casting dimensions may vary by .25" due to casting variations.

<sup>3</sup> Shaft extension tolerances: +.0000"; -.0005" for shafts up to 1.5" diameter "U". Larger diameter: "U", +.000"; -.001".

<sup>4</sup> Motor dimensions for other than "Type T" three phase TEFC motors, refer to pages B-114 to B-116.

## 2-Stage Output Shafted Flange Mount OtN31 - 32

Standard conduit box location will be opposite flange unless specified otherwise.

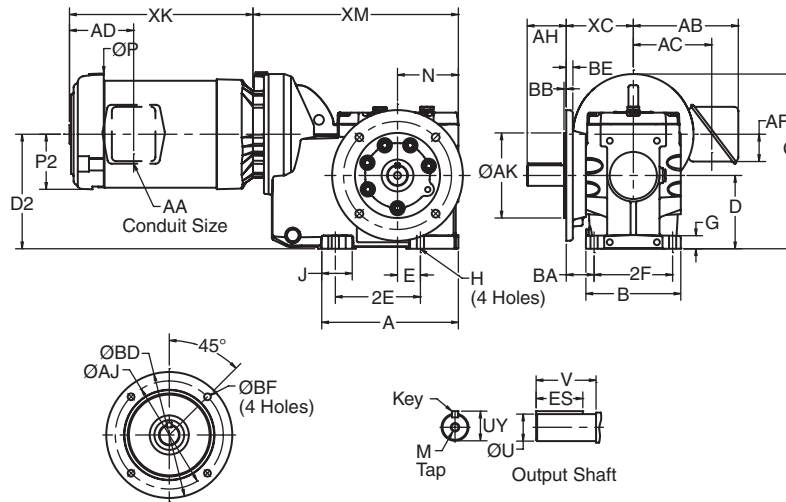

OtN Series

Gear Frame	Version	A	B	D <sup>1</sup>	D <sub>2</sub>	E	2E	2F	G	H	J	O	N	BA	XC	XM
3132	S2	5.88	4.65	3.15	4.98	1.97	3.94	3.94	.56	.35	1.53	8.01	3.15	1.54	3.50	10.59
3242	S2	8.22	5.71	4.41	6.89	1.38	5.12	4.72	.79	.43	1.83	10.51	3.66	1.67	4.04	12.36

### Output Shaft

Gear Frame	Version	U <sup>3</sup>	UY	V	AH	Key	ES	M
3132	S2	1.000	1.10	1.97	1.97	1/4 Sq.	1.34	3/8-16 X .87
3242	S2	1.250	1.35	2.36	2.35	1/4 Sq.	2.03	1/2-13 X 1.13

### Output Flange

Gear Frame	Flange Code	AK	AJ	BB	BD	BE	BF
3132	5	4.331	5.12	.14	6.50	.39	.35
	6	3.740	4.53	.14	5.51	.44	.35
3242	5	5.118	6.50	.14	7.87	.39	.47
	6	7.087	8.46	.16	9.84	.47	.55

Motor Frame	Motor Type <sup>4</sup>	Gear Frame	P	P <sub>2</sub>	AA	AB	AC	AD	AF	XK
56	T	Any	7.31	3.31	.75	6.10	4.50	3.86	1.77	9.79
B56	T	Any	7.31	3.31	.75	6.10	4.50	3.86	1.77	11.04
143T, 145T	T	Any	7.31	3.31	.75	6.10	4.50	3.86	1.77	11.04
182T/184T	T	Any	9.56	4.34	.75	6.10	4.50	5.13	1.77	14.04
213T	T	32	11.25	5.06	1.00	8.42	7.17	5.60	2.42	16.15
215T	T	32	11.25	5.06	1.00	8.42	7.17	5.60	2.42	17.65

<sup>1</sup> Dimension "D" will never be exceeded, but may vary from values shown. When exact dimensions are required, shims up to .03" may be necessary.

<sup>2</sup> All rough casting dimensions may vary by .25" due to casting variations.

<sup>3</sup> Shaft extension tolerances: +.0000"; -.0005" for shafts up to 1.5" diameter "U". Larger diameter: "U", +.000"; -.001".

<sup>4</sup> Motor dimensions for other than "Type T" three phase TEFC motors, refer to pages B-114 to B-116.

## 3-Stage Output Shafted Flange Mount OtN32 - 33

Standard conduit box location will be opposite flange unless specified otherwise.

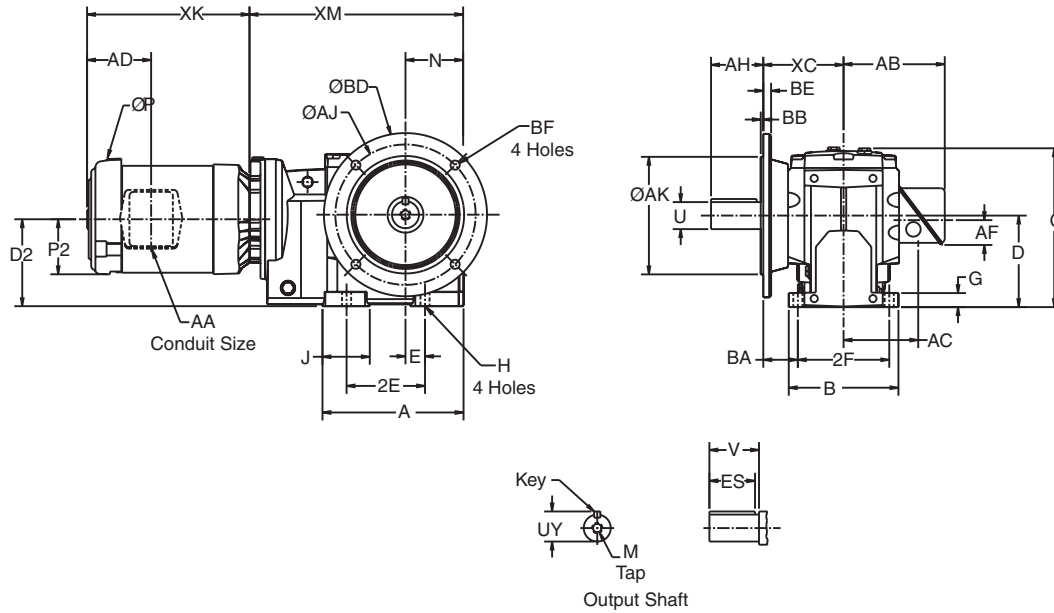

OtN Series

Gear Frame	Version	A	B	D <sup>1</sup>	D2	E	2E	2F	G	H	J	O	N	BA	XC	XM
32	S1,S2	7.81	5.71	4.41	3.78	1.38	5.12	4.71	.73	.43	2.34	8.09	3.03	1.81	4.04	10.98
33	S1,S2	8.50	6.61	5.51	5.24	1.18	4.72	5.51	.85	.55	2.86	9.69	3.54	2.24	4.84	12.90

### Output Shaft

Gear Frame	Version	U <sup>3</sup>	UY	V	AH	Key	ES	M
32	S2	1.250	1.354	2.38	2.36	1/4 Sq.	2.06	1/2-13 X 1.12
	S1	1.250	1.354	1.77	1.75	1/4 Sq.	1.45	1/2-13 X 1.12
33	S2	1.625	1.783	3.25	3.15	3/8 Sq.	2.78	5/8-11 X 1.38
	S1	1.500	1.657	3.18	2.28	3/8 Sq.	2.19	5/8-11 X 1.38

### Output Flange

Gear Frame	Flange Code	AK	AJ	BB	BD	BE	BF
32	5	5.118	6.50	.14	7.87	.39	.47
	6	7.087	8.46	.16	9.84	.47	.55
33	5	7.087	8.46	.16	9.84	.47	.55
	6	9.055	10.43	.16	11.81	.47	.55

Motor Frame	Motor Type <sup>4</sup>	Gear Frame	P	P2	AA	AB	AC	AD	AF	XK
56	T	Any	7.31	3.31	.75	6.10	4.50	3.86	1.77	9.79
B56	T	Any	7.31	3.31	.75	6.10	4.50	3.86	1.77	11.04
143T, 145T	T	Any	7.31	3.31	.75	6.10	4.50	3.86	1.77	11.04
182T/184T	T	Any	9.56	4.34	.75	6.10	4.50	5.13	1.77	14.04
213T	T	32	11.25	5.06	1.00	8.42	7.17	5.60	2.42	16.15
215T	T	32	11.25	5.06	1.00	8.42	7.17	5.60	2.42	17.65

<sup>1</sup> Dimension "D" will never be exceeded, but may vary from values shown. When exact dimensions are required, shims up to .03" may be necessary.

<sup>2</sup> All rough casting dimensions may vary by .25" due to casting variations.

<sup>3</sup> Shaft extension tolerances: +.0000"; -.0005" for shafts up to 1.5" diameter "U". Larger diameter: "U", +.000"; -.001".

<sup>4</sup> Motor dimensions for other than "Type T" three phase TEFC motors, refer to pages B-114 to B-116.

## 3-Stage Output Shafted Flange Mount OtN34 - 35

Standard conduit box location will be opposite flange unless specified otherwise.

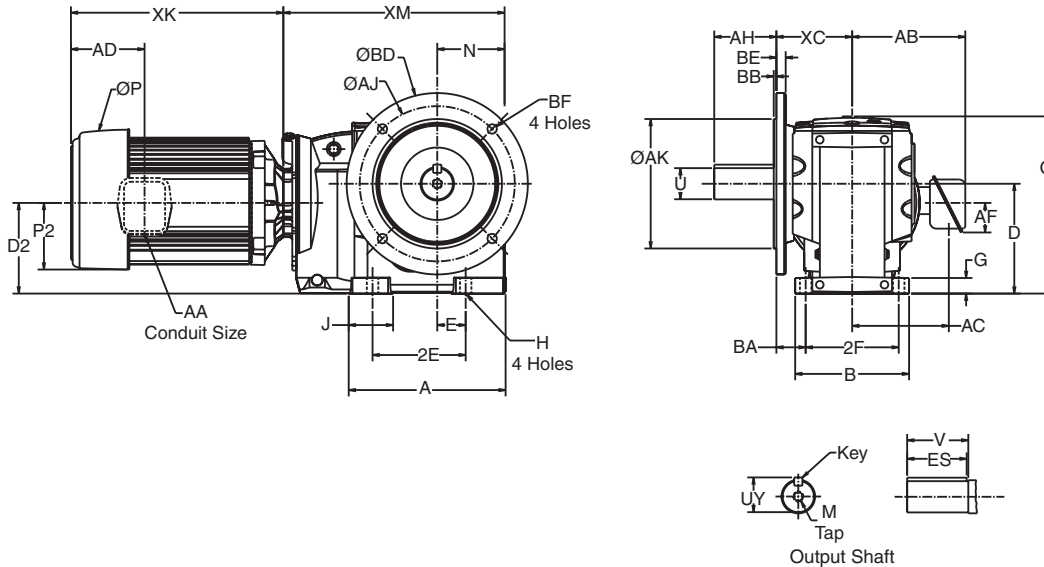

OtN Series

Gear Frame	Version	A	B	D <sup>1</sup>	D <sub>2</sub>	E	2E	2F	G	H	J	O	N	BA	XC	XM	
																56T-215T	254T-286T
34	S1,S2	10.13	7.87	7.09	5.90	1.57	5.91	6.50	1.07	.71	2.67	12.05	4.49	1.93	5.18	14.56	-
35	S2	11.92	8.66	8.35	6.89	2.17	7.09	7.09	1.19	.87	3.45	13.58	5.20	2.22	5.76	16.90	17.25

### Output Shaft

Gear Frame	Version	U <sup>3</sup>	UY	V	AH	Key	ES	M
34	S2	2.000	2.210	3.94	3.94	1/2 Sq.	3.06	3/4-10 X 1.61
	S1	1.750	1.909	3.56	3.28	3/8 Sq.	3.56	3/4-10 X 1.61
35	S2	2.375	2.638	4.72	4.72	5/8 Sq.	3.81	3/4-10 X 1.61

### Output Flange

Gear Frame	Flange Code	AK	AJ	BB	BD	BE	BF
34	5	9.055	10.43	.16	11.81	.59	.55
	6	9.842	11.80	.16	13.77	.59	.71
35	5	9.842	11.80	.20	13.77	.71	.71
	6	11.810	13.77	.20	15.75	.71	.71

Motor Frame	Motor Type <sup>4</sup>	Gear Frame	P	P <sub>2</sub>	AA	AB	AC	AD	AF	XK
56	T	Any	7.31	3.31	.75	6.10	4.50	3.86	1.77	9.79
B56	T	Any	7.31	3.31	.75	6.10	4.50	3.86	1.77	11.04
143T, 145T	T	Any	7.31	3.31	.75	6.10	4.50	3.86	1.77	11.04
182T/184T	T	Any	9.56	4.34	.75	6.10	4.50	5.13	1.77	14.04
213T	T	Any	11.25	5.06	1.00	8.42	7.17	5.60	2.42	16.15
215T	T	Any	11.25	5.06	1.00	8.42	7.17	5.60	2.42	17.65
254T	T	34	13.38	6.00	1.25	9.79	7.68	8.29	1.81	20.58
	T	35	13.38	6.00	1.25	9.79	7.68	8.29	1.81	19.61
256T	T	34	13.38	6.00	1.25	9.79	7.68	8.29	1.81	22.33
	T	35	13.38	6.00	1.25	9.79	7.68	8.29	1.81	21.36
284T/286T	T	35 - 37	14.62	7.29	1.50	11.33	8.51	12.44	2.63	24.26

<sup>1</sup> Dimension "D" will never be exceeded, but may vary from values shown. When exact dimensions are required, shims up to .03" may be necessary.

<sup>2</sup> All rough casting dimensions may vary by .25" due to casting variations.

<sup>3</sup> Shaft extension tolerances: +.0000"; -.0005" for shafts up to 1.5" diameter "U". Larger diameter: "U", +.000"; -.001".

<sup>4</sup> Motor dimensions for other than "Type T" three phase TEFC motors, refer to pages B-114 to B-116.

## 3-Stage Output Shafted Flange Mount OtN36 - 38

Standard conduit box location will be opposite flange unless specified otherwise.

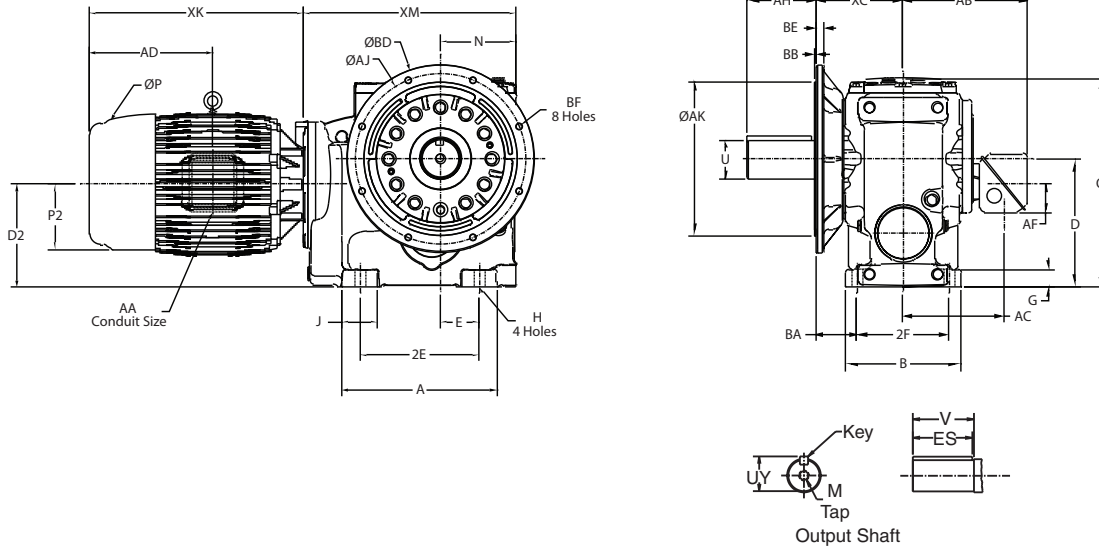

OtN Series

Gear Frame	Version	A	B	D <sup>1</sup>	D <sub>2</sub>	E	2E	2F	G	H	J	O	N	BA	XC	XM		
																182T/184T	213T-215T	254T-UP
36	S2	17.06	11.41	8.86	8.86	6.99	13.98	9.45	1.57	.87	3.87	16.26	8.74	4.45	9.17	23.38	23.38	23.73
37	S2	20.58	12.99	9.84	10.98	8.27	16.54	10.63	1.93	.94	4.78	18.29	10.04	4.45	9.76	-	29.06	29.41
38	S2	17.85	13.39	14.76	11.87	4.53	13.78	10.63	1.98	1.26	4.06	24.11	8.86	4.65	9.96	-	24.29	24.64

### Output Shaft

Gear Frame	Version	U <sup>3</sup>	UY	V	AH	Key	ES	M
36	S2	2.875	3.200	7.68	5.51	3/4 SQ.	5.00	3/4-10 X 1.61
37	S2	3.625	4.010	8.88	6.69	7/8 SQ.	6.00	1-8 X 2.13
38	S2	4.375	4.809	8.99	9.97	1.00 SQ.	7.00	1-8 X 2.25

### Output Flange

Gear Frame	Flange Code	AK	AJ	BB	BD	BE	BF
36 & 37	5	13.78	15.75	.236	17.70	.79	.71
	6	17.72	19.68	.236	21.65	.63	.87
38	5	17.72	19.69	.200	21.65	.79	.69
	6	21.65	23.62	.236	25.98	.63	.87

Motor Frame	Motor Type <sup>4</sup>	Gear Frame	P	P2	AA	AB	AC	AD	AF	XK
182T/184T	T	36	9.56	4.34	.75	6.10	4.50	5.13	1.77	14.04
213T	T	All	11.25	5.06	1.00	8.42	7.17	5.60	2.42	16.15
215T	T	All	11.25	5.06	1.00	8.42	7.17	5.60	2.42	17.65
254T	T	All	13.38	6.00	1.25	9.79	7.68	8.29	1.81	19.61
256T	T	All	13.38	6.00	1.25	9.79	7.68	8.29	1.81	21.36
284T/286T	T	All	14.62	7.29	1.50	11.33	8.51	12.44	2.63	24.26
324T/326T	T	All	17.2	7.78	2.00	14.99	11.34	14.16	3.63	27.36

<sup>1</sup> Dimension "D" will never be exceeded, but may vary from values shown. When exact dimensions are required, shims up to .03" may be necessary.

<sup>2</sup> All rough casting dimensions may vary by .25" due to casting variations.

<sup>3</sup> Shaft extension tolerances: +.0000"; -.0005" for shafts up to 1.5" diameter "U". Larger diameter: "U", +.000"; -.001".

<sup>4</sup> Motor dimensions for other than "Type T" three phase TEFC motors, refer to pages B-114 to B-116.

## Combined Output Shafted Flange Mount OtN32 - 33

Standard conduit box location will be opposite flange unless specified otherwise.

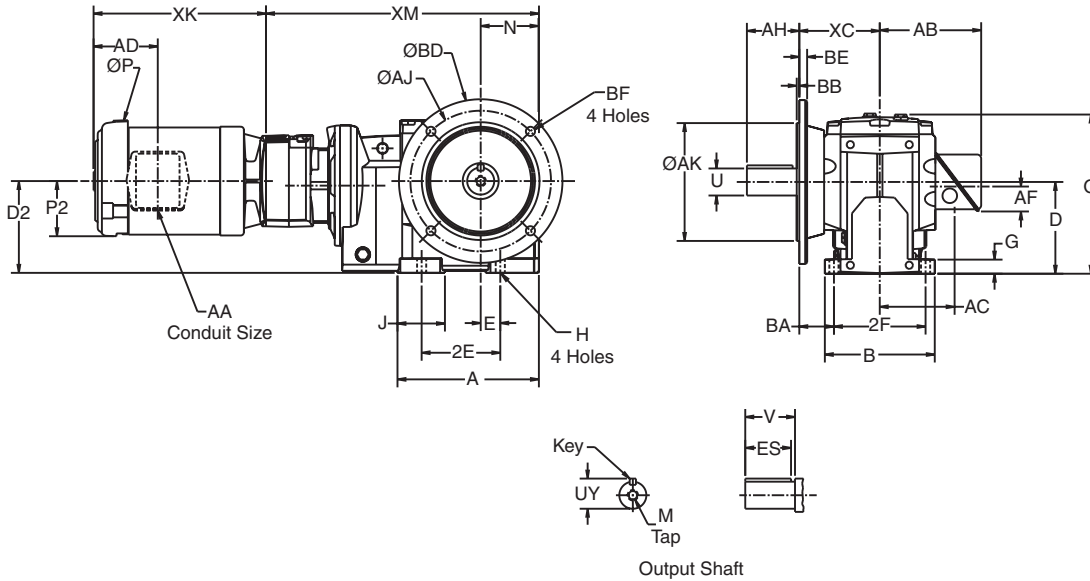

Gear Frame	Version	A	B	D'	D2	E	2E	2F	G	H	J	O	N	BA	XC	XM
32	S1,S2	7.81	5.71	4.41	4.06	1.38	5.12	4.71	.73	.43	2.34	8.09	3.03	1.81	4.04	14.49
33	S1,S2	8.50	6.61	5.51	4.91	1.18	4.72	5.51	.85	.55	2.86	9.69	3.54	2.24	4.84	19.90

### Output Shaft

Gear Frame	Version	U <sup>3</sup>	UY	V	AH	Key	ES	M
32	S2	1.250	1.354	2.38	2.36	1/4 Sq.	2.06	1/2-13 X 1.12
	S1	1.250	1.354	1.77	1.75	1/4 Sq.	1.45	1/2-13 X 1.12
33	S2	1.625	1.783	3.25	3.15	3/8 Sq.	2.78	5/8-11 X 1.38
	S1	1.500	1.657	3.18	2.28	3/8 Sq.	2.19	5/8-11 X 1.38

### Output Flange

Gear Frame	Flange Code	AK	AJ	BB	BD	BE	BF
32	5	5.118	6.50	.14	7.87	.39	.47
	6	7.087	8.46	.16	9.84	.47	.55
33	5	7.087	8.46	.16	9.84	.47	.55
	6	9.055	10.43	.16	11.81	.47	.55

Motor Frame	Motor Type <sup>4</sup>	Gear Frame	P	P2	AA	AB	AC	AD	AF	XK
56	T	32	7.31	3.31	.75	6.10	4.50	3.86	1.77	10.37
	T	33	7.31	3.31	.75	6.10	4.50	3.86	1.77	9.79
B56	T	32	7.31	3.31	.75	6.10	4.50	3.86	1.77	11.62
	T	33	7.31	3.31	.75	6.10	4.50	3.86	1.77	11.04
143T, 145T	T	33	7.31	3.31	.75	6.10	4.50	3.86	1.77	11.04

<sup>1</sup> Dimension "D" will never be exceeded, but may vary from values shown. When exact dimensions are required, shims up to .03" may be necessary.

<sup>2</sup> All rough casting dimensions may vary by .25" due to casting variations.

<sup>3</sup> Shaft extension tolerances: +.0000"; -.0005" for shafts up to 1.5" diameter "U". Larger diameter: "U", +.000"; -.001".

<sup>4</sup> Motor dimensions for other than "Type T" three phase TEFC motors, refer to pages B-114 to B-116.



## Combined Output Shafted Flange Mount OtN34 - 35

Standard conduit box location will be opposite flange unless specified otherwise.

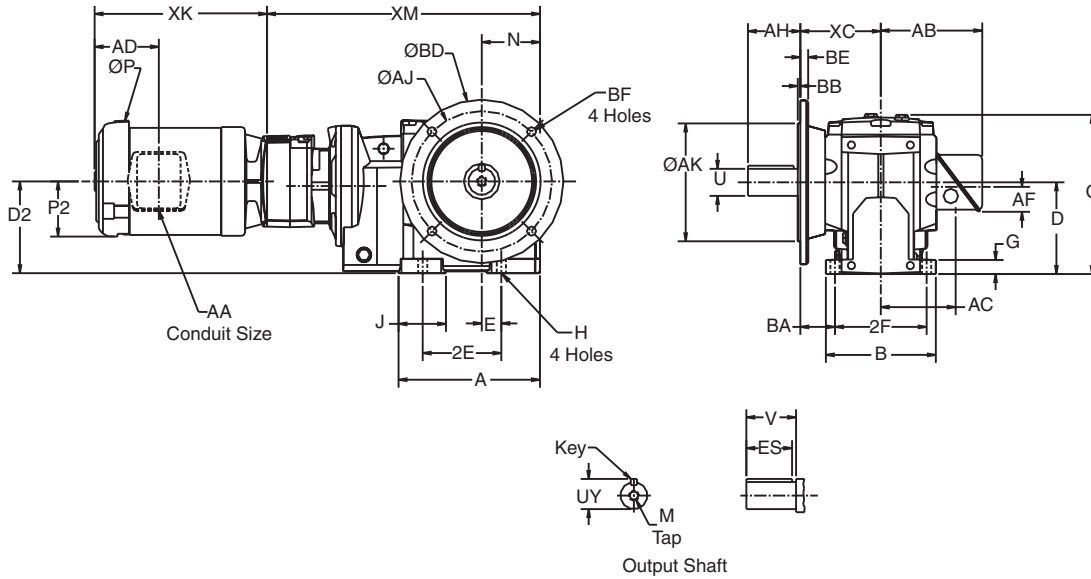

# OtN Series

Gear Frame	Version	A	B	D <sup>1</sup>	D <sub>2</sub>	E	2E	2F	G	H	J	O	N	BA	XC	XM
34	S1, S2	10.13	7.87	7.09	5.57	1.57	5.91	6.50	1.07	.71	2.67	12.05	4.49	1.93	5.18	21.55
35	S2	11.92	8.66	8.35	6.56	2.17	7.09	7.09	1.19	.87	3.45	13.58	5.20	2.22	5.76	23.87

### Output Shaft

Gear Frame	Version	U <sup>3</sup>	UY	V	AH	Key	ES	M
34	S2	2.000	2.21	3.94	3.94	1/2 Sq.	3.06	3/4-10 X 1.61
	S1	1.750	1.909	3.56	3.28	3/8 Sq.	3.56	3/4-10 X 1.61
35	S2	2.375	2.638	4.72	4.72	5/8 Sq.	3.81	3/4-10 X 1.61

### Output Flange

Gear Frame	Flange Code	AK	AJ	BB	BD	BE	BF
34	5	9.055	10.43	.16	11.81	.59	.55
	6	9.842	11.80	.16	13.77	.59	.71
35	5	9.842	11.80	.20	13.77	.71	.71
	6	11.810	13.77	.20	15.75	.71	.71

Motor Frame	Motor Type <sup>4</sup>	Gear Frame	P	P <sub>2</sub>	AA	AB	AC	AD	AF	XK
56	T	Any	7.31	3.31	.75	6.10	4.50	3.86	1.77	9.79
B56	T	Any	7.31	3.31	.75	6.10	4.50	3.86	1.77	11.04
143T, 145T	T	Any	7.31	3.31	.75	6.10	4.50	3.86	1.77	11.04
182T/184T	T	35	9.56	4.34	.75	6.10	4.50	5.13	1.77	14.04

<sup>1</sup> Dimension "D" will never be exceeded, but may vary from values shown. When exact dimensions are required, shims up to .03" may be necessary.

<sup>2</sup> All rough casting dimensions may vary by .25" due to casting variations.

<sup>3</sup> Shaft extension tolerances: +.0000"; -.0005" for shafts up to 1.5" diameter "U". Larger diameter: ".000"; -.001".

<sup>4</sup> Motor dimensions for other than "Type T" three phase TEFC motors, refer to pages B-114 to B-116.

## Combined Output Shafted Flange Mount OtN36 - 38

Standard conduit box location will be opposite flange unless specified otherwise.

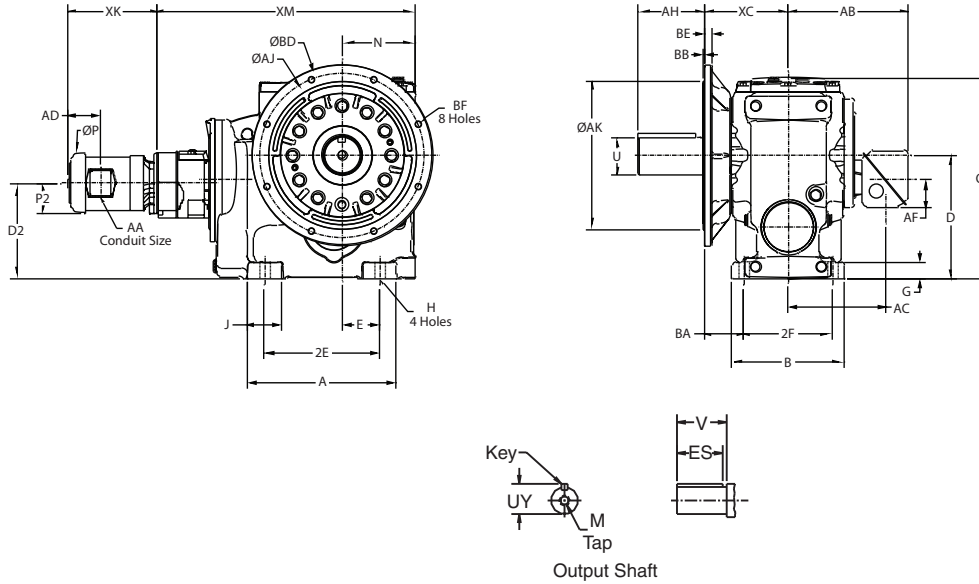

OtN Series

Gear Frame	Version	A	B	D <sup>1</sup>	D2	E	2E	2F	G	H	J	O	N	BA	XC	XM
																56 -215T
36	S2	17.06	11.41	8.86	8.46	6.99	13.98	9.45	1.57	.87	3.87	16.26	8.74	4.45	9.17	31.04
37	S2	20.58	12.99	9.84	10.57	8.27	16.54	10.63	1.93	.94	4.78	18.29	10.04	4.45	9.76	36.37
38	S2	17.85	13.39	14.76	11.48	4.53	13.78	10.63	1.98	1.26	4.06	24.11	8.86	4.65	9.96	31.94

### Output Shaft

Gear Frame	Version	U <sup>3</sup>	UY	V	AH	Key	ES	M
36	S2	2.875	3.20	7.68	5.51	3/4 SQ.	5.00	3/4-10 X 1.61
37	S2	3.625	4.01	8.88	6.69	7/8 SQ.	6.00	1-8 X 2.13
38	S2	4.375	4.809	8.99	9.97	1.00 SQ.	7.00	1-8 X 2.25

### Output Flange

Gear Frame	Flange Code	AK	AJ	BB	BD	BE	BF
36 & 37	5	13.78	15.75	.236	17.70	.79	.71
	6	17.72	19.68	.236	21.65	.63	.87
38	5	17.72	19.69	.200	21.65	.79	.69
	6	21.65	23.62	.236	25.98	.63	.87

Motor Frame	Motor Type <sup>4</sup>	Gear Frame	P	P2	AA	AB	AC	AD	AF	XK
56	T	All	7.31	3.31	.75	6.10	4.50	3.86	1.77	9.79
B56	T	All	7.31	3.31	.75	6.10	4.50	3.86	1.77	11.04
143T, 145T	T	All	7.31	3.31	.75	6.10	4.50	3.86	1.77	11.04
182T/184T	T	All	9.56	4.34	.75	6.10	4.50	5.13	1.77	14.04
213T	T	All	11.25	5.06	1.00	8.42	7.17	5.60	2.42	16.15
215T	T	All	11.25	5.06	1.00	8.42	7.17	5.60	2.42	17.65

<sup>1</sup> Dimension "D" will never be exceeded, but may vary from values shown. When exact dimensions are required, shims up to .03" may be necessary.

<sup>2</sup> All rough casting dimensions may vary by .25" due to casting variations.

<sup>3</sup> Shaft extension tolerances: +.0000"; -.0005" for shafts up to 1.5" diameter "U". Larger diameter: "U", +.000"; -.001".

<sup>4</sup> Motor dimensions for other than "Type T" three phase TEFC motors, refer to pages B-114 to B-116.

## 2-Stage Finished Bore Hollow Shaft OtN31 - 32

Standard conduit box location will be F1 unless specified otherwise.

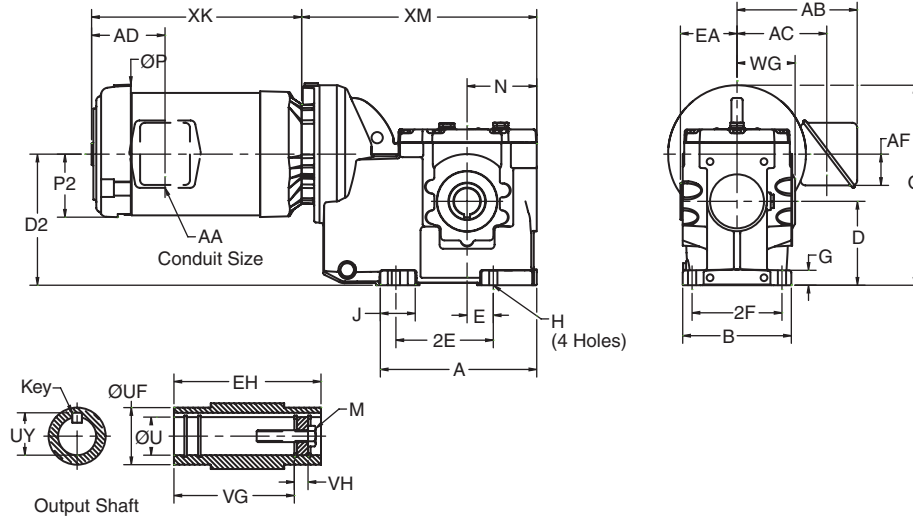

# OtN Series

Gear Frame	Version	A	B	D <sup>1</sup>	D2	E	2E	2F	G	H	J	O	N	WG	XM
3132	S2	5.88	4.65	3.15	4.98	1.97	3.94	3.94	.56	.35	1.53	8.01	3.15	2.85	10.59
3242	S2	8.22	5.71	4.41	6.89	1.38	5.12	4.72	.79	.43	1.83	10.51	3.66	3.22	12.36

### Output Shaft

Gear Frame	Version	EA	EH	U <sup>3,7</sup>	UF	UY	VG	VH	Key <sup>5</sup>	M
3132	S2	2.56	5.12	1.250	1.77	1.372	4.31	.37	1/4 X 1/4 X 1 1/2	7/16-14 X 1.00
3242	S2	2.97	5.94	1.375	1.96	1.523	5.06	.37	5/16 X 5/16 1 13/16	1/2-13 X 1.00

Motor Frame	Motor Type <sup>8</sup>	Gear Frame	P	P2	AA	AB	AC	AD	AF	XK
56	T	Any	7.31	3.31	.75	6.10	4.50	3.86	1.77	9.79
B56	T	Any	7.31	3.31	.75	6.10	4.50	3.86	1.77	11.04
143T, 145T	T	Any	7.31	3.31	.75	6.10	4.50	3.86	1.77	11.04
182T/184T	T	Any	9.56	4.34	.75	6.10	4.50	5.13	1.77	14.04
213T	T	32	11.25	5.06	1.00	8.42	7.17	5.60	2.42	16.15
215T	T	32	11.25	5.06	1.00	8.42	7.17	5.60	2.42	17.65

<sup>1</sup> Dimension "D" will never be exceeded, but may vary from values shown. When exact dimensions are required, shims up to .03" may be necessary.

<sup>2</sup> All rough casting dimensions may vary by .25" due to casting variations.

<sup>3</sup> Refer to page B-26 by gear frame for Tapered Bushed designs if driven shaft varies from "U" dimensions offered above.

<sup>4</sup> Driven shaft entry can be from either side of the gear reducer housing by reversing positioning of the snap rings and washer illustrated.

<sup>5</sup> Output key not supplied.

<sup>6</sup> For details of the torque arm kit, refer to page B-22.

<sup>7</sup> Output bore tolerance: +.0020", -.0000" for all diameters.

<sup>8</sup> Motor dimensions for other than "Type T" three phase TEFC motors, refer to pages B-114 to B-116.

## 3-Stage Finished Bore Hollow Shaft OtN32 - 33

Standard conduit box location will be F1 unless specified otherwise.

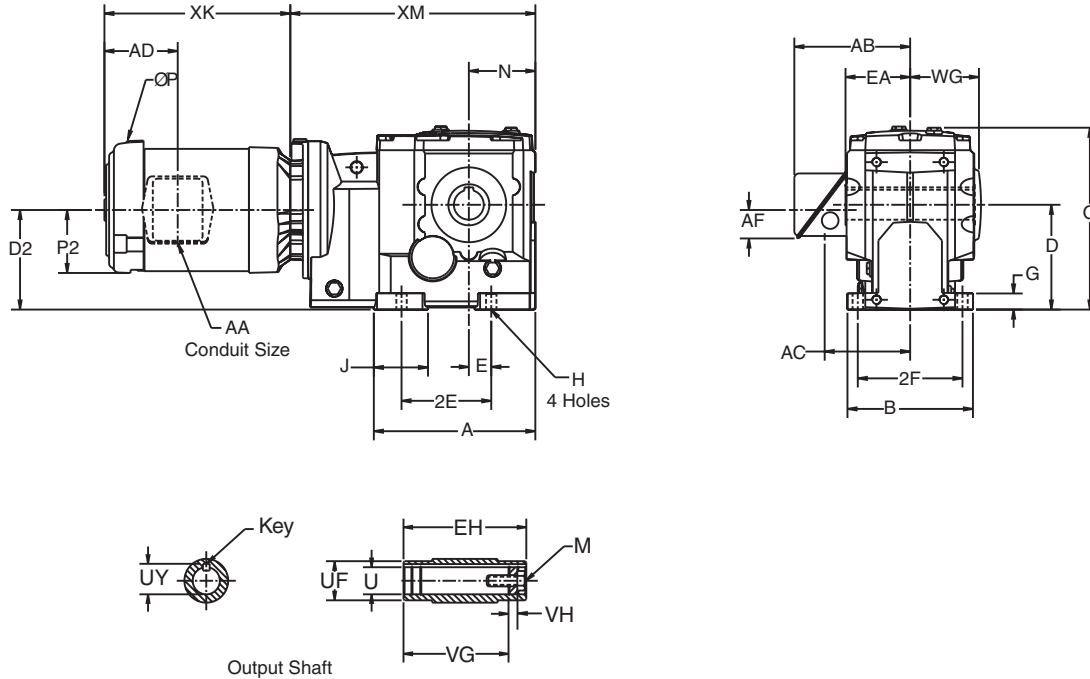

Gear Frame	Version	A	B	D <sup>1</sup>	D2	E	2E	2F	G	H	J	O	N	WG	XM
32	S2	7.81	5.71	4.41	3.78	1.38	5.12	4.71	.73	.43	2.34	8.09	3.03	3.22	10.98
33	S2	8.50	6.61	5.51	5.24	1.18	4.72	5.51	.85	.55	2.86	9.69	3.54	3.73	12.90

### Output Shaft

Gear Frame	Version	EA	EH	U <sup>3,7</sup>	UF	UY	VG	VH	Key <sup>5</sup>	M
32	S2	2.98	5.95	1.375	1.96	1.523	5.20	.55	5/16 X 5/16 X 1 13/16	1/2-13 X 1.00
33	S2	3.47	6.94	1.500	2.16	1.674	5.96	.55	3/8 X 3/8 X 2 1/4	5/8-11 X 1.75

Motor Frame	Motor Type <sup>8</sup>	Gear Frame	P	P2	AA	AB	AC	AD	AF	XK
56	T	Any	7.31	3.31	.75	6.10	4.50	3.86	1.77	9.79
B56	T	Any	7.31	3.31	.75	6.10	4.50	3.86	1.77	11.04
143T, 145T	T	Any	7.31	3.31	.75	6.10	4.50	3.86	1.77	11.04
182T/184T	T	Any	9.56	4.34	.75	6.10	4.50	5.13	1.77	14.04
213T	T	33	11.25	5.06	1.00	8.42	7.17	5.60	2.42	16.15
215T	T	33	11.25	5.06	1.00	8.42	7.17	5.60	2.42	17.65

<sup>1</sup> Dimension "D" will never be exceeded, but may vary from values shown. When exact dimensions are required, shims up to .03" may be necessary.

<sup>2</sup> All rough casting dimensions may vary by .25" due to casting variations.

<sup>3</sup> Refer to page B-26 by gear frame for Tapered Bushed designs if driven shaft varies from "U" dimensions offered above.

<sup>4</sup> Driven shaft entry can be from either side of the gear reducer housing

by reversing positioning of the snap rings and washer illustrated.

<sup>5</sup> Output key not supplied.

<sup>6</sup> For details of the torque arm kit, refer to page B-22.

<sup>7</sup> Output bore tolerance: +.0020", -.0000" for all diameters.

<sup>8</sup> Motor dimensions for other than "Type T" three phase TEFC motors, refer to pages B-114 to B-116.

## 3-Stage Finished Bore Hollow Shaft OtN34 - 35

Standard conduit box location will be F1 unless specified otherwise.

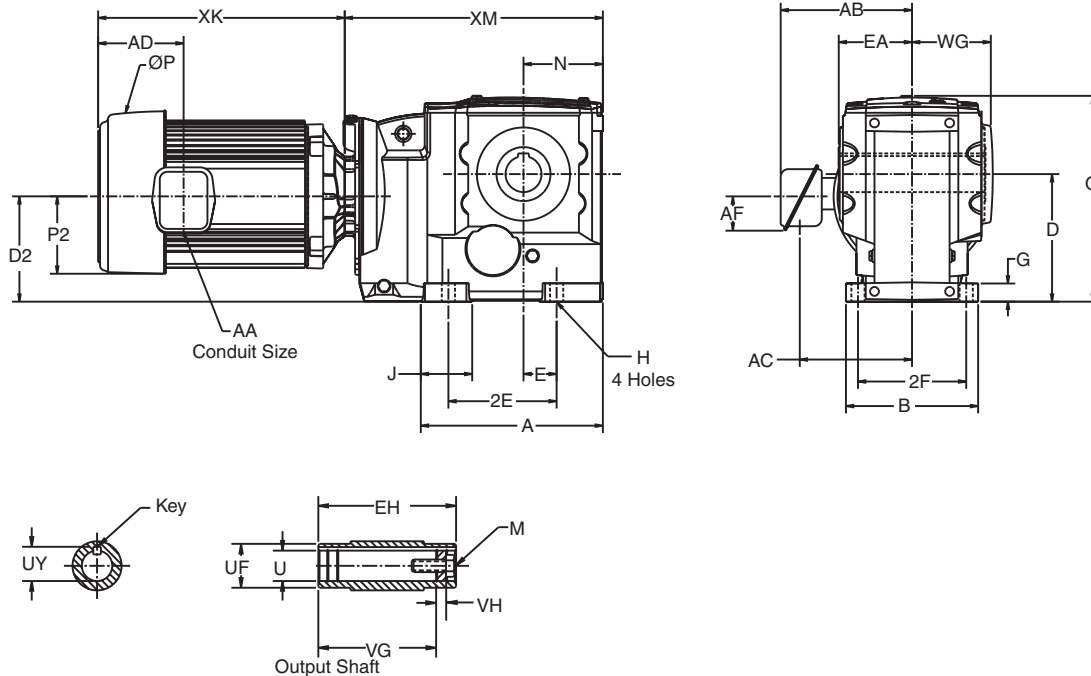

OtN Series

Gear Frame	Version	A	B	D <sup>1</sup>	D2	E	2E	2F	G	H	J	O	N	WG	XM	
															56T-215T	254T-286T
34	S2	10.13	7.87	7.09	5.90	1.57	5.91	6.50	1.07	.71	2.67	12.05	4.49	4.66	14.56	-
35	S2	11.92	8.66	8.35	6.89	2.17	7.09	7.09	1.18	.87	3.45	13.58	5.20	5.15	16.90	17.25

### Output Shaft

Gear Frame	Version	EA	EH	U <sup>3 7</sup>	UF	UY	VG	VH	Key <sup>5</sup>	M
34	S2	4.49	8.97	2.000	2.56	2.210	7.44	.79	1/2 X 7/16 X 2 5/8	5/8-11 X 1.75
35	S2	4.83	9.66	2.375	3.54	2.656	8.15	.94	5/8 X 5/8 X 3 5/8	3/4-10 X 2.00

Motor Frame	Motor Type <sup>8</sup>	Gear Frame	P	P2	AA	AB	AC	AD	AF	XK
56	T	Any	7.31	3.31	.75	6.10	4.50	3.86	1.77	9.79
B56	T	Any	7.31	3.31	.75	6.10	4.50	3.86	1.77	11.04
143T, 145T	T	Any	7.31	3.31	.75	6.10	4.50	3.86	1.77	11.04
182T/184T	T	Any	9.56	4.34	.75	6.10	4.50	5.13	1.77	14.04
213T	T	Any	11.25	5.06	1.00	8.42	7.17	5.60	2.42	16.15
215T	T	Any	11.25	5.06	1.00	8.42	7.17	5.60	2.42	17.65
254T	T	34	13.38	6.00	1.25	9.79	7.68	8.29	1.81	20.58
		35	13.38	6.00	1.25	9.79	7.68	8.29	1.81	19.61
256T	T	34	13.38	6.00	1.25	9.79	7.68	8.29	1.81	22.33
		35	13.38	6.00	1.25	9.79	7.68	8.29	1.81	21.36
284T/286T	T	35	14.62	7.29	1.50	11.33	8.51	12.44	2.63	24.26

<sup>1</sup> Dimension "D" will never be exceeded, but may vary from values shown. When exact dimensions are required, shims up to .03" may be necessary.  
<sup>2</sup> All rough casting dimensions may vary by .25" due to casting variations.  
<sup>3</sup> Refer to page B-26 by gear frame for Tapered Bushed designs if driven shaft varies from "U" dimensions offered above.  
<sup>4</sup> Driven shaft entry can be from either side of the gear reducer housing

by reversing positioning of the snap rings and washer illustrated.  
<sup>5</sup> Output key supplied on frame 34 only.  
<sup>6</sup> For details of the torque arm kit, refer to page B-22.  
<sup>7</sup> Output bore tolerance: +.0020", -.0000" for all diameters.  
<sup>8</sup> Motor dimensions for other than "Type T" three phase TEFC motors, refer to pages B-114 to B-116.

## 3-Stage Finished Bore Hollow Shaft OtN36 - 38

Standard conduit box location will be F1 unless specified otherwise.

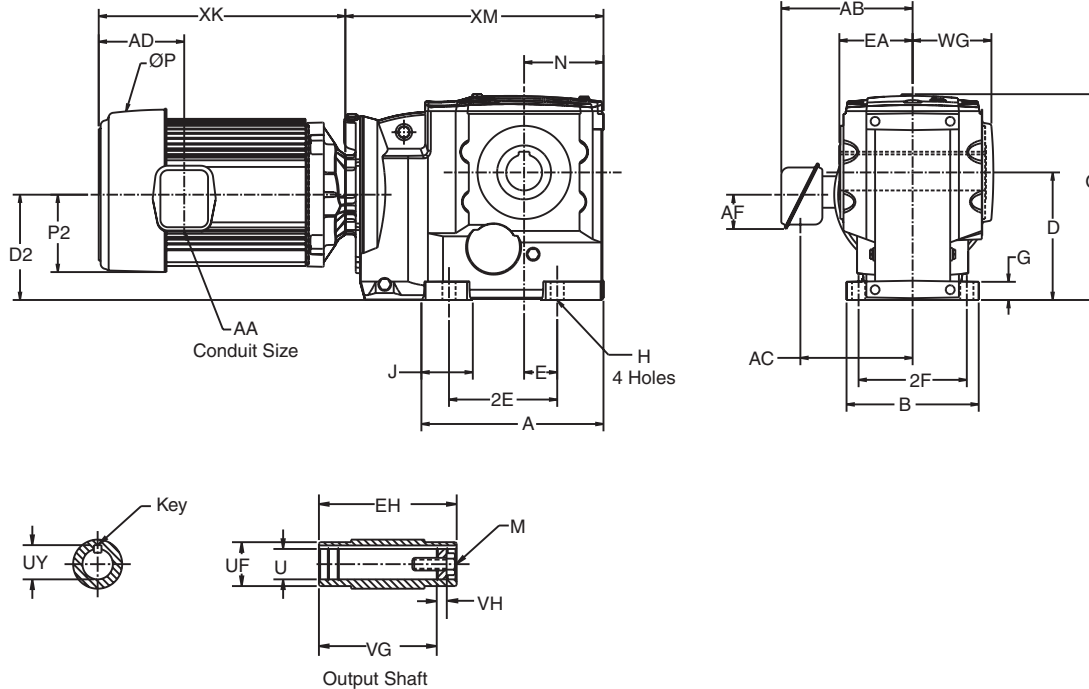

OtN Series

Gear Frame	Version	A	B	D <sup>1</sup>	D2	E	2E	2F	G	H	J	O	N	WG	XM		
															182T/184T	213T-215T	254T-UP
36	S2	17.06	11.41	8.86	8.86	6.99	13.98	9.45	1.57	.87	3.87	16.26	8.74	6.78	23.38	23.38	23.73
37	S2	20.58	12.99	9.84	10.98	8.27	16.54	10.63	1.93	.94	4.78	18.29	10.04	7.44	-	29.06	29.41
38	S2	17.85	13.39	14.76	11.87	4.53	13.78	10.63	1.98	1.26	4.06	24.11	8.86	7.40	-	24.29	24.64

### Output Shaft

Gear Frame	Version	EA	EH	U <sup>3,7</sup>	UF	UY	VG	VH	Key <sup>8</sup>	M
36	S2	6.22	12.44	2.750	3.93	3.037	10.89	1.23	5/8 X 5/8 X 5 1/2	3/4-10 X 2.00
37	S2	6.80	13.59	3.625	4.72	4.019	11.90	1.23	7/8 X 7/8 X 5 1/2	3/4-10 X 2.00
38	S2	6.81	13.74	4.000	5.50	4.316	11.86	.92	1 X 1 X 6 1/2	1-8 X 2.25

Motor Frame	Motor Type <sup>7</sup>	Gear Frame	P	P2	AA	AB	AC	AD	AF	XK
182T/184T	T	36	9.56	4.34	.75	6.10	4.50	5.13	1.77	14.04
213T	T	All	11.25	5.06	1.00	8.42	7.17	5.60	2.42	16.15
215T	T	All	11.25	5.06	1.00	8.42	7.17	5.60	2.42	17.65
254T	T	All	13.38	6.00	1.25	9.79	7.68	8.29	1.81	19.61
256T	T	All	13.38	6.00	1.25	9.79	7.68	8.29	1.81	21.36
284T/286T	T	All	14.62	7.29	1.50	11.33	8.51	12.44	2.63	24.26
324T/326T	T	All	17.2	7.78	2.00	14.99	11.34	14.16	3.63	27.36

<sup>1</sup> Dimension "D" will never be exceeded, but may vary from values shown. When exact dimensions are required, shims up to .03" may be necessary.

<sup>2</sup> All rough casting dimensions may vary by .25" due to casting variations.

<sup>3</sup> Driven shaft entry can be from either side of the gear reducer housing

by reversing positioning of the snap rings and washer illustrated.

<sup>5</sup> For details of the torque arm kit, refer to pages B-22 and B-23.

<sup>6</sup> Output bore tolerance: +.0020", -.0000" for all diameters.

<sup>7</sup> Motor dimensions for other than "Type T" three phase TEFC motors, refer to pages B-114 to B-116.

<sup>8</sup> Key not supplied with reducer.



## Combined Finished Bore Hollow Shaft OtN32 - 33

Standard conduit box location will be F1 unless specified otherwise.

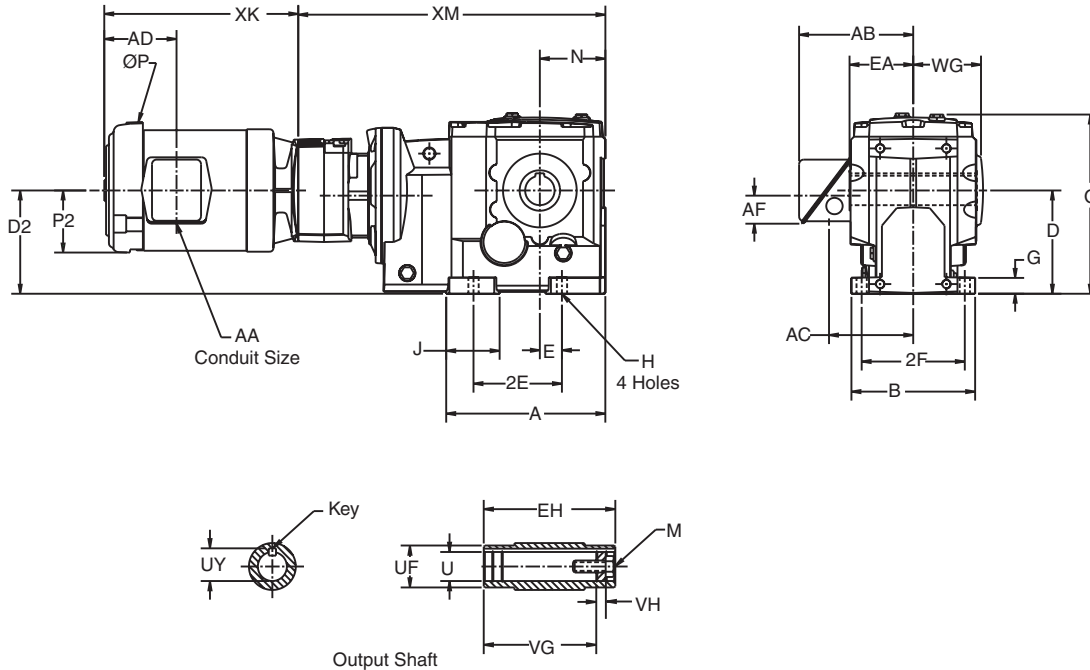

OtN Series

Gear Frame	Version	A	B	D <sup>1</sup>	D2	E	2E	2F	G	H	J	O	N	WG	XM
32	S2	7.81	5.71	4.41	4.06	1.38	5.12	4.71	.73	.43	2.34	8.09	3.03	3.22	14.49
33	S2	8.50	6.61	5.51	4.91	1.18	4.72	5.51	.85	.55	2.86	9.69	3.54	3.73	19.90

### Output Shaft

Gear Frame	Version	EA	EH	U <sup>3</sup> 6	UF	UY	VG	VH	Key <sup>8</sup>	M
32	S2	2.98	5.96	1.375	1.96	1.523	5.20	.55	5/16 X 5/16 X 1 13/16	1/2-13 X 1.00
33	S2	3.47	6.94	1.500	2.16	1.674	5.96	.55	3/8 X 3/8 X 2 1/4	5/8-11 X 1.75

Motor Frame	Motor Type <sup>7</sup>	Gear Frame	P	P2	AA	AB	AC	AD	AF	XK
56	T	32	7.31	3.31	.75	6.10	4.50	3.86	1.77	10.37
	T	33	7.31	3.31	.75	6.10	4.50	3.86	1.77	9.79
B56	T	32	7.31	3.31	.75	6.10	4.50	3.86	1.77	11.62
	T	33	7.31	3.31	.75	6.10	4.50	3.86	1.77	11.04
143T, 145T	T	32	7.31	3.31	.75	6.10	4.50	3.86	1.77	11.62
	T	33	7.31	3.31	.75	6.10	4.50	3.86	1.77	11.04

<sup>1</sup> Dimension "D" will never be exceeded, but may vary from values shown. When exact dimensions are required, shims up to .03" may be necessary.

<sup>2</sup> All rough casting dimensions may vary by .25" due to casting variations.

<sup>3</sup> Refer to page B-26 by gear frame for Tapered Bushed designs if driven shaft varies from "U" dimensions offered above.

<sup>4</sup> Driven shaft entry can be from either side of the gear reducer housing by reversing positioning of the snap rings and washer illustrated.

<sup>5</sup> For details of the torque arm kit, refer to page B-22.

<sup>6</sup> Output bore tolerance: +.0020", -.0000" for all diameters.

<sup>7</sup> Motor dimensions for other than "Type T" three phase TEFC motors, refer to pages B-114 to B-116.

<sup>8</sup> Output key not supplied.

## Combined Finished Bore Hollow Shaft OtN34 - 35

Standard conduit box location will be F1 unless specified otherwise.

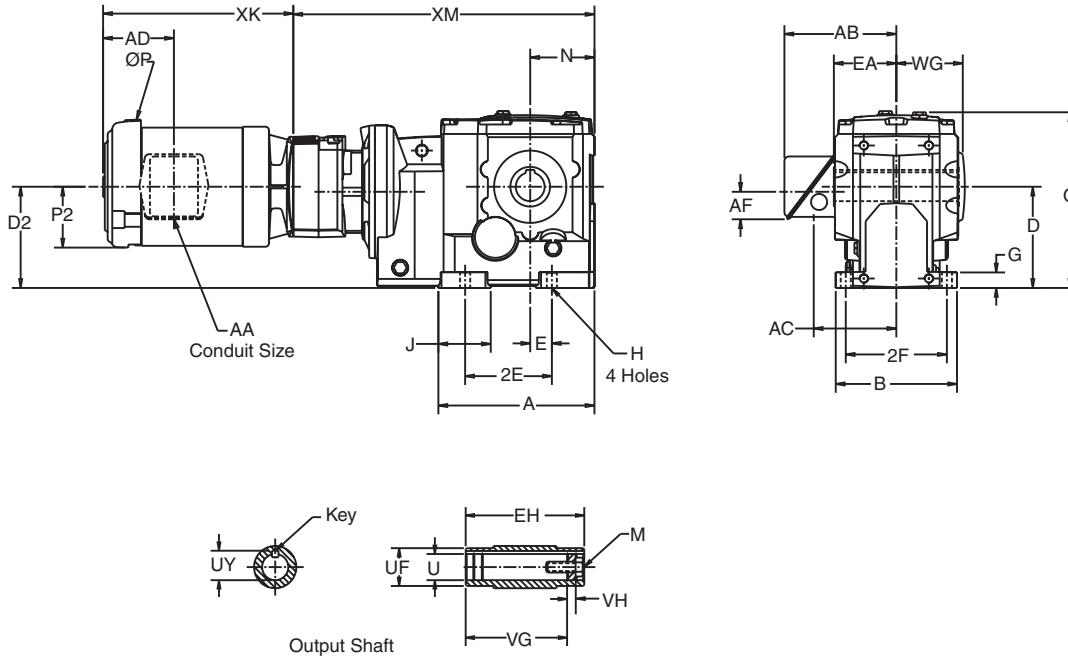

Gear Frame	Version	A	B	D <sup>1</sup>	D <sub>2</sub>	E	2E	2F	G	H	J	O	N	WG	XM
34	S2	10.13	7.87	7.09	5.57	1.57	5.91	6.50	1.07	.71	2.67	12.05	4.49	4.66	21.55
35	S2	11.92	8.66	8.35	6.56	2.17	7.09	7.09	1.18	.87	3.45	13.58	5.20	5.15	23.87

### Output Shaft

Gear Frame	Version	EA	EH	U <sup>3 7</sup>	UF	UY	VG	VH	Key <sup>5</sup>	M
34	S2	4.49	8.97	2.000	2.56	2.210	7.44	.79	1/2 X 7/16 X 2 5/8	5/8-11 X 1.75
35	S2	4.83	9.66	2.375	3.54	2.656	8.15	.94	5/8 X 5/8 X 3 5/8	3/4-10 X 2.00

Motor Frame	Motor Type <sup>8</sup>	Gear Frame	P	P <sub>2</sub>	AA	AB	AC	AD	AF	XK
56	T	Any	7.31	3.31	.75	6.10	4.50	3.86	1.77	9.79
B56	T	Any	7.31	3.31	.75	6.10	4.50	3.86	1.77	11.04
143T, 145T	T	Any	7.31	3.31	.75	6.10	4.50	3.86	1.77	11.04
182T/184T	T	35	9.56	4.34	.75	6.10	4.50	5.13	1.77	14.04

<sup>1</sup> Dimension "D" will never be exceeded, but may vary from values shown. When exact dimensions are required, shims up to .03" may be necessary.

<sup>2</sup> All rough casting dimensions may vary by .25" due to casting variations.

<sup>3</sup> Refer to page B-26 by gear frame for Tapered Bushed designs if driven shaft varies from "U" dimensions offered above.

<sup>4</sup> Driven shaft entry can be from either side of the gear reducer housing

by reversing positioning of the snap rings and washer illustrated.

<sup>5</sup> Output key supplied on frame 34 only.

<sup>6</sup> For details of the torque arm kit, refer to page B-22.

<sup>7</sup> Output bore tolerance: +.0020", - .0000" for all diameters.

<sup>8</sup> Motor dimensions for other than "Type T" three phase TEFC motors, refer to pages B-114 to B-116.

## Combined Finished Bore Hollow Shaft OtN36 - 38

Standard conduit box location will be F1 unless specified otherwise.

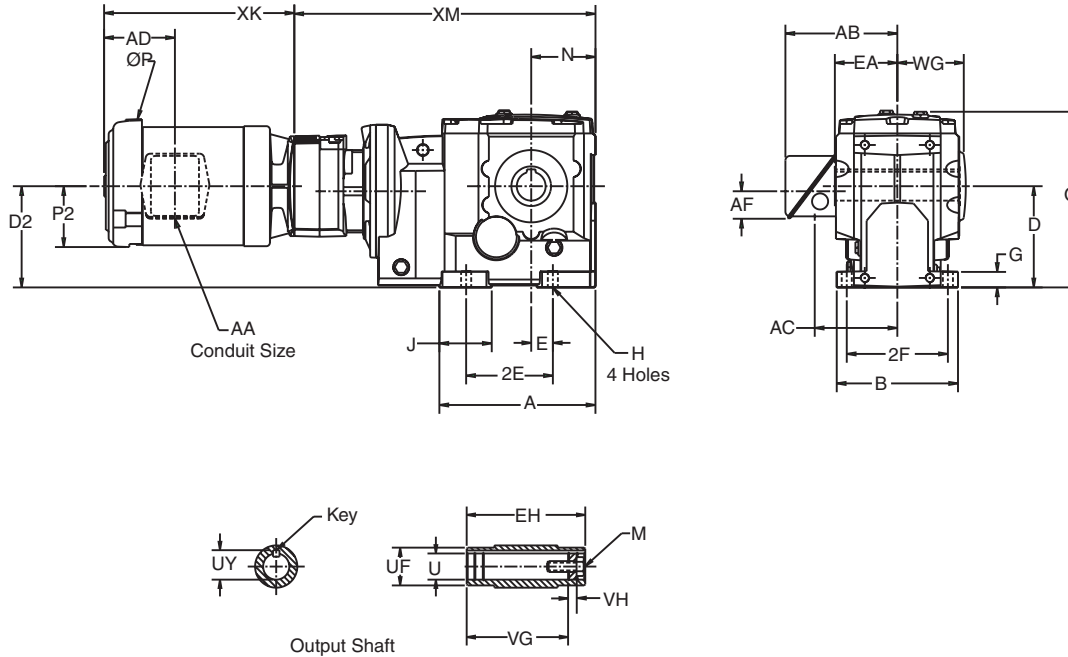

OtN Series

Gear Frame	Version	A	B	D <sup>1</sup>	D2	E	2E	2F	G	H	J	O	N	WG	XM
															56 -215T
36	S2	17.06	11.41	8.86	8.46	6.99	13.98	9.45	1.57	.87	3.87	16.26	8.74	6.78	31.04
37	S2	20.58	12.99	9.84	10.57	8.27	16.54	10.63	1.93	.94	4.78	18.29	10.04	7.44	36.37
38	S2	17.85	13.39	14.76	11.48	4.53	13.78	10.63	1.98	1.26	4.06	24.11	8.86	7.40	31.94

### Output Shaft

Gear Frame	Version	EA	EH	U <sup>3,7</sup>	UF	UY	VG	VH	Key <sup>5</sup>	M
36	S2	6.22	12.44	2.750	3.93	3.037	10.89	1.23	5/8 X 5/8 X 5 1/2	3/4-10 X 2.00
37	S2	6.80	13.59	3.625	4.72	4.019	11.90	1.23	7/8 X 7/8 X 5 1/2	3/4-10 X 2.00
38	S2	6.81	13.74	4.000	5.50	4.316	11.86	.92	1 x 1 x 6 1/2	1-8 x 2.25

Motor Frame	Motor Type <sup>4</sup>	Gear Frame	P	P2	AA	AB	AC	AD	AF	XK
56	T	All	7.31	3.31	.75	6.10	4.50	3.86	1.77	9.79
B56	T	All	7.31	3.31	.75	6.10	4.50	3.86	1.77	11.04
143T, 145T	T	All	7.31	3.31	.75	6.10	4.50	3.86	1.77	11.04
182T/184T	T	All	9.56	4.34	.75	6.10	4.50	5.13	1.77	14.04
213T	T	All	11.25	5.06	1.00	8.42	7.17	5.60	2.42	16.15
215T	T	All	11.25	5.06	1.00	8.42	7.17	5.60	2.42	17.65

<sup>1</sup> Dimension "D" will never be exceeded, but may vary from values shown. When exact dimensions are required, shims up to .03" may be necessary.

<sup>2</sup> All rough casting dimensions may vary by .25" due to casting variations.

<sup>3</sup> Driven shaft entry can be from either side of the gear reducer housing

by reversing positioning of the snap rings and washer illustrated.

<sup>4</sup> For details of the torque arm kit, refer to pages B-22 and B-23.

<sup>5</sup> Output bore tolerance: +.0020", -.0000" for all diameters.

<sup>6</sup> Motor dimensions for other than "Type T" three phase TEFC motors, refer to pages B-114 to B-116.

## 2-Stage Finished Bore Hollow Shaft Face Mount - OtN31 - 32

Standard conduit box location will be opposite face mounting unless specified otherwise.

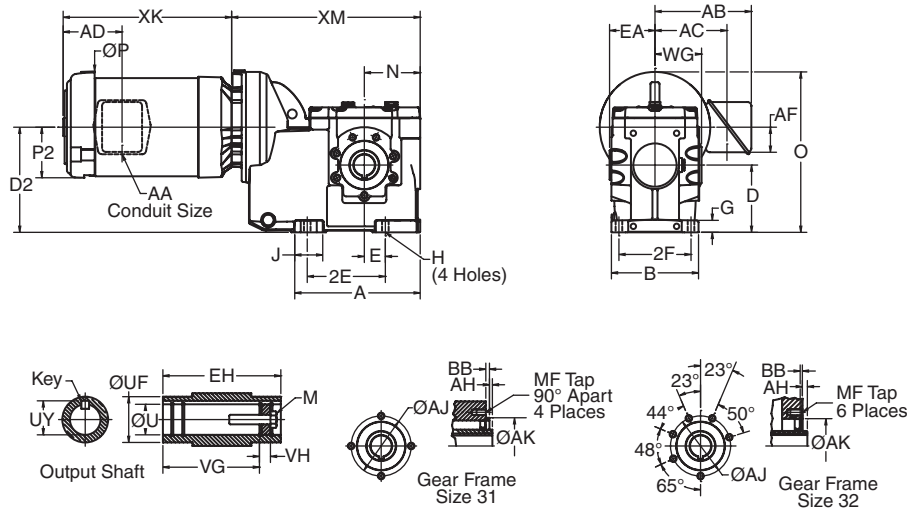

Gear Frame	Version	A	B	D <sup>1</sup>	D <sub>2</sub>	E	2E	2F	G	H	J	O	N	WG	XM
3132	S2	5.88	4.65	3.15	4.98	1.97	3.94	3.94	.56	.35	1.53	8.01	3.15	2.85	10.59
3242	S2	8.22	5.71	4.41	6.89	1.38	5.12	4.72	.79	.43	1.83	10.51	3.66	3.22	12.36

### Output Shaft

Gear Frame	Version	EA	EH	U <sup>5</sup>	UF	UY	VG	VH	Key <sup>6</sup>	M
3132	S2	2.56	5.12	1.250	1.77	1.372	4.31	.37	1/4 X 1/4 X 1 1/2	7/16-14 X 1.00
3242	S2	2.97	5.94	1.375	1.96	1.523	5.06	.37	5/16 X 5/16 1 13/16	1/2-13 X 1.00

Motor Frame	Motor Type <sup>4</sup>	Gear Frame	P	P <sub>2</sub>	AA	AB	AC	AD	AF	XK
56	T	Any	7.31	3.31	.75	6.10	4.50	3.86	1.77	9.79
B56	T	Any	7.31	3.31	.75	6.10	4.50	3.86	1.77	11.04
143T, 145T	T	Any	7.31	3.31	.75	6.10	4.50	3.86	1.77	11.04
182T/184T	T	Any	9.56	4.34	.75	6.10	4.50	5.13	1.77	14.04
213T	T	32	11.25	5.06	1.00	8.42	7.17	5.60	2.42	16.15
215T	T	32	11.25	5.06	1.00	8.42	7.17	5.60	2.42	17.65

<sup>1</sup> Dimension "D" will never be exceeded, but may vary from values shown. When exact dimensions are required, shims up to .03" may be necessary.

<sup>2</sup> All rough casting dimensions may vary by .25" due to casting variations.

<sup>3</sup> Driven shaft entry can be from either side of the gear reducer housing by reversing positioning of the snap rings and washer illustrated.

<sup>4</sup> Motor dimensions for other than "Type T" three phase TEFC motors, refer to pages B-114 to B-116.

<sup>5</sup> Output bore tolerance: +.0020", - .0000" for all diameters.

<sup>6</sup> Output key not supplied.

## 3-Stage Finished Bore Hollow Shaft Face Mount - OtN32 - 33

Standard conduit box location will be opposite face mounting unless specified otherwise.

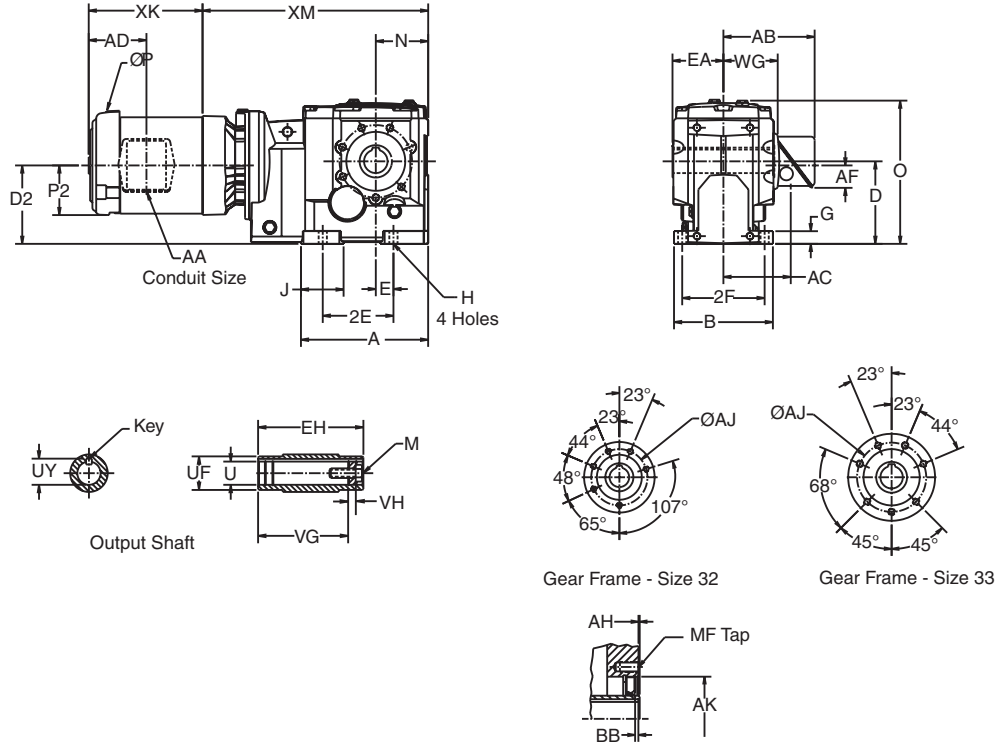

# OtN Series

Gear Frame	Version	A	B	D <sup>1</sup>	D2	E	2E	2F	G	H	J	O	N	WG	XM
32	S2	7.81	5.71	4.41	3.78	1.38	5.12	4.71	.73	.43	2.34	8.09	3.03	3.15	10.98
33	S2	8.50	6.61	5.51	5.24	1.18	4.72	5.51	.85	.55	2.86	9.69	3.54	3.63	12.90

### Output Shaft

Gear Frame	Version	EA	EH	U <sup>5</sup>	UF	UY	VG	VH	Key <sup>6</sup>	M
32	S2	2.98	5.95	1.375	1.96	1.523	5.20	.55	5/16 X 5/16 X 1 13/16	1/2-13 X 1.00
33	S2	3.47	6.94	1.500	2.16	1.674	5.96	.55	3/8 X 3/8 X 2 1/4	5/8-11 X 1.75

### Face Mount

Gear Frame	Flange Code	AH	AJ	AK	BB	MF
32	S2	.12	3.94	3.15	.16	M10-1.50 X 22
33	S2	.12	4.84	3.94	.16	M12-1.75 X 22

Motor Frame	Motor Type <sup>3</sup>	Gear Frame	P	P2	AA	AB	AC	AD	AF	XK
56	T	Any	7.31	3.31	.75	6.10	4.50	3.86	1.77	9.79
B56	T	Any	7.31	3.31	.75	6.10	4.50	3.86	1.77	11.04
143T, 145T	T	Any	7.31	3.31	.75	6.10	4.50	3.86	1.77	11.04
182T/184T	T	Any	9.56	4.34	.75	6.10	4.50	5.13	1.77	14.04
213T	T	33	11.25	5.06	1.00	8.42	7.17	5.60	2.42	16.15
215T	T	33	11.25	5.06	1.00	8.42	7.17	5.60	2.42	17.65

<sup>1</sup> Dimension "D" will never be exceeded, but may vary from values shown. When exact dimensions are required, shims up to .03" may be necessary.

<sup>2</sup> All rough casting dimensions may vary by .25" due to casting variations.

<sup>3</sup> Motor dimensions for other than "Type T" three phase TEFC motors,

refer to pages B-114 to B-116.

<sup>4</sup> Driven shaft entry can be from either side of the gear reducer housing by reversing positioning of the snap rings and washer illustrated.

<sup>5</sup> Output bore tolerance: +.0020", - .0000" for all diameters.

<sup>6</sup> Output key not supplied.

**3-Stage Finished Bore Hollow Shaft  
Face Mount - OtN34 - 35**

Standard conduit box location will be opposite face mounting unless specified otherwise.

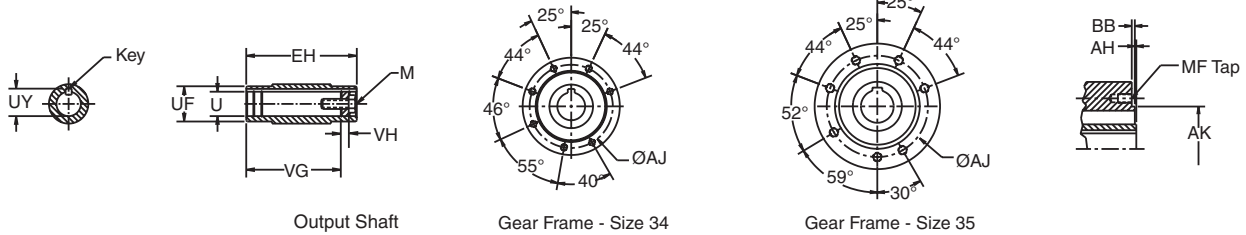
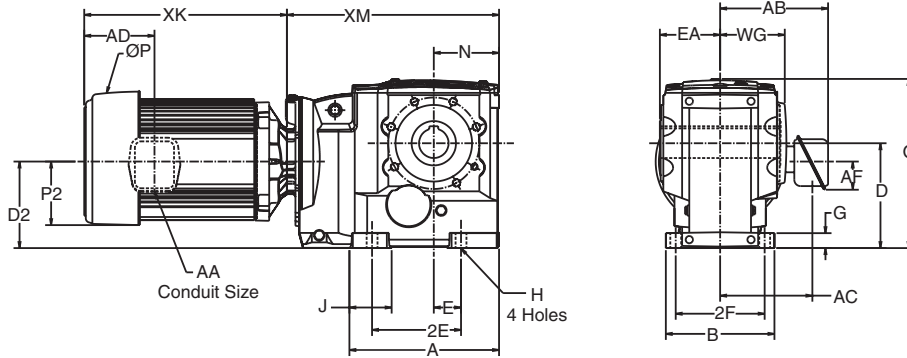

OtN Series

Gear Frame	Version	A	B	D <sup>1</sup>	D2	E	2E	2F	G	H	J	O	N	WG	XM	
															56T-215T	254T-286T
34	S2	10.13	7.87	7.09	5.90	1.57	5.91	6.50	1.07	.71	2.67	12.05	4.49	4.66	14.56	-
35	S2	11.92	8.66	8.35	6.89	2.17	7.09	7.09	1.18	.87	3.45	13.58	5.20	5.15	16.90	17.25

**Output Shaft**

Gear Frame	Version	EA	EH	U <sup>6</sup>	UF	UY	VG	VH	Key <sup>5</sup>	M
34	S2	4.49	8.97	2.000	2.56	2.210	7.44	.79	1/2 X 7/16 X 2 5/8	5/8-11 X 1.75
35	S2	4.83	9.66	2.375	3.54	2.656	8.15	.94	5/8 X 5/8 X 3 5/8	3/4-10 X 2.00

**Face Mount**

Gear Frame	Version	AH	AJ	AK	BB	MF
34	S2	.14	5.98	5.12	.28	M12-1.75 X 22
35	S2	.13	7.48	6.10	.28	M16-2.00 X 27

Motor Frame	Motor Type <sup>3</sup>	Gear Frame	P	P2	AA	AB	AC	AD	AF	XK
56	T	Any	7.31	3.31	.75	6.10	4.50	3.86	1.77	9.79
B56	T	Any	7.31	3.31	.75	6.10	4.50	3.86	1.77	11.04
143T, 145T	T	Any	7.31	3.31	.75	6.10	4.50	3.86	1.77	11.04
182T/184T	T	Any	9.56	4.34	.75	6.10	4.50	5.13	1.77	14.04
213T	T	Any	11.25	5.06	1.00	8.42	7.17	5.60	2.42	16.15
215T	T	Any	11.25	5.06	1.00	8.42	7.17	5.60	2.42	17.65
254T	T	34	13.38	6.00	1.25	9.79	7.68	8.29	1.81	20.58
	T	35	13.38	6.00	1.25	9.79	7.68	8.29	1.81	19.61
256T	T	34	13.38	6.00	1.25	9.79	7.68	8.29	1.81	22.33
	T	35	13.38	6.00	1.25	9.79	7.68	8.29	1.81	21.36
284T/286T	T	35	14.62	7.29	1.50	11.33	8.51	12.44	2.63	24.26

<sup>1</sup> Dimension "D" will never be exceeded, but may vary from values shown. When exact dimensions are required, shims up to .03" may be necessary.

<sup>2</sup> All rough casting dimensions may vary by .25" due to casting variations.

<sup>3</sup> Motor dimensions for other than "Type T" three phase TEFC motors, **B-86**

refer to pages B-114 to B-116.

<sup>4</sup> Driven shaft entry can be from either side of the gear reducer housing by reversing positioning of the snap rings and washer illustrated.

<sup>5</sup> Output key supplied on frame 34 only.

<sup>6</sup> Output bore tolerance: +.0020", - .0000" for all diameters.

## 3-Stage Finished Bore Hollow Shaft Face Mount - OtN36 - 38

Standard conduit box location will be opposite face mounting unless specified otherwise.

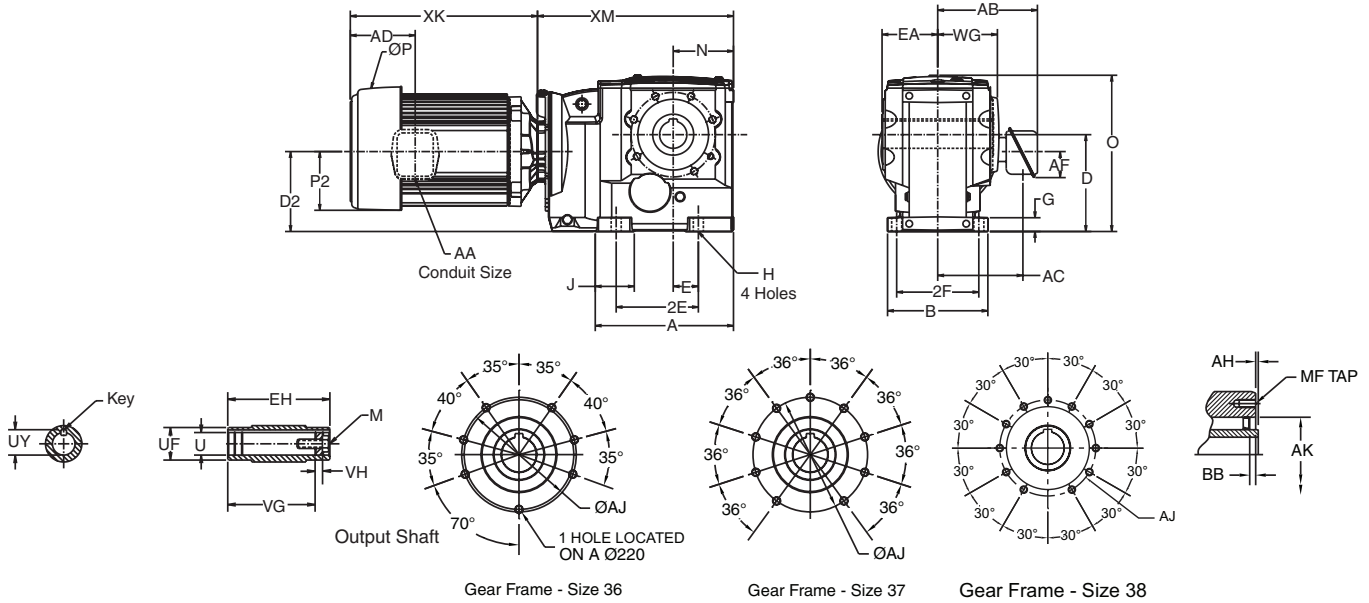

# OtN Series

Gear Frame	Version	A	B	D <sup>1</sup>	D2	E	2E	2F	G	H	J	O	N	WG	XM		
															182T/184T	213T-215T	254T-UP
36	S2	17.06	11.41	8.86	8.86	6.99	13.98	9.45	1.57	.87	3.87	16.26	8.74	6.78	23.38	23.38	23.73
37	S2	20.58	12.99	9.84	10.98	8.27	16.54	10.63	1.93	.94	4.78	18.29	10.04	7.44	-	29.06	29.41
38	S2	17.85	13.39	14.76	11.87	4.53	13.78	10.63	1.98	1.26	4.06	24.11	8.86	7.40	-	24.29	24.64

### Output Shaft

Gear Frame	Version	EA	EH	U <sup>3,5</sup>	UF	UY	VG	VH	Key <sup>6</sup>	M
36	S2	6.22	12.44	2.750	3.93	3.037	10.89	1.23	5/8 X 5/8 X 5 1/2	3/4-10 X 2.00
37	S2	6.80	13.59	3.625	4.72	4.019	11.90	1.23	7/8 X 7/8 X 5 1/2	3/4-10 X 2.00
38	S2	6.81	13.74	4.000	5.50	4.316	11.86	.92	1 x 1 X 6 1/2	1-8 X 2.25

### Face Mount

Gear Frame	Version	AH	AJ	AK	BB	MF
36	S2	.20	9.06	5.91	.28	M16-2.0 X 27
37	S2	.20	9.06	7.09	.28	M20-2.5 X 35
38	S2	.10	11.81	9.84	.20	M20-2.00 X 35

Motor Frame	Motor Type <sup>4</sup>	Gear Frame	P	P2	AA	AB	AC	AD	AF	XK
182T/184T	T	36	9.56	4.34	.75	6.10	4.50	5.13	1.77	14.04
213T	T	All	11.25	5.06	1.00	8.42	7.17	5.60	2.42	16.15
215T	T	All	11.25	5.06	1.00	8.42	7.17	5.60	2.42	17.65
254T	T	All	13.38	6.00	1.25	9.79	7.68	8.29	1.81	19.61
256T	T	All	13.38	6.00	1.25	9.79	7.68	8.29	1.81	21.36
284T/286T	T	All	14.62	7.29	1.50	11.33	8.51	12.44	2.63	24.26
324T/326T	T	All	17.2	7.78	2.00	14.99	11.34	14.16	3.63	27.36

<sup>1</sup> Dimension "D" will never be exceeded, but may vary from values shown. When exact dimensions are required, shims up to .03" may be necessary.

<sup>2</sup> All rough casting dimensions may vary by .25" due to casting variations.

<sup>3</sup> Motor dimensions for other than "Type T" three phase TEFC motors,

refer to pages B-114 to B-116.

<sup>4</sup> Driven shaft entry can be from either side of the gear reducer housing by reversing positioning of the snap rings and washer illustrated.

<sup>5</sup> Output bore tolerance: +.0020", -.0000" for all diameters.

<sup>6</sup> Output key not supplied with reducer



## Combined Finished Bore Hollow Shaft Face Mount - OtN32 - 33

Standard conduit box location will be opposite face mounting unless specified otherwise.

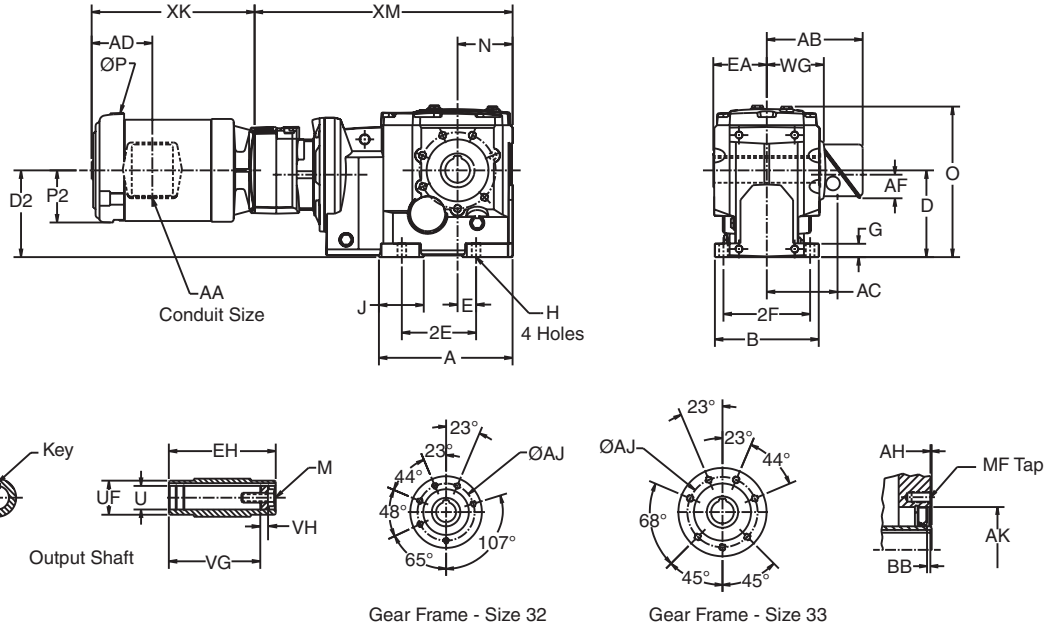

OtN Series

Gear Frame	Version	A	B	D <sup>1</sup>	D2	E	2E	2F	G	H	J	O	N	WG	XM
32	S2	7.81	5.71	4.41	4.06	1.38	5.12	4.71	.73	.43	2.34	8.09	3.03	3.15	14.49
33	S2	8.50	6.61	5.51	4.91	1.18	4.72	5.51	.85	.55	2.86	9.69	3.54	3.63	19.90

### Output Shaft

Gear Frame	Version	EA	EH	U <sup>5</sup>	UF	UY	VG	VH	Key <sup>6</sup>	M
32	S2	2.98	5.96	1.375	1.96	1.523	5.20	.55	5/16 X 5/16 X 1 13/16	1/2-13 X 1.00
33	S2	3.47	6.94	1.500	2.16	1.674	5.96	.55	3/8 X 3/8 X 2 1/4	5/8-11 X 1.75

### Face Mount

Gear Frame	Version	AH	AJ	AK	BB	MF
32	S2	.12	3.94	3.15	.16	M10-1.50 X 22
33	S2	.12	4.84	3.94	.16	M12-1.75 X 22

Motor Frame	Motor Type <sup>3</sup>	Gear Frame	P	P2	AA	AB	AC	AD	AF	XK
56	T	32	7.31	3.31	.75	6.10	4.50	3.86	1.77	10.37
	T	33	7.31	3.31	.75	6.10	4.50	3.86	1.77	9.79
B56	T	32	7.31	3.31	.75	6.10	4.50	3.86	1.77	11.62
	T	33	7.31	3.31	.75	6.10	4.50	3.86	1.77	11.04
143T, 145T	T	33	7.31	3.31	.75	6.10	4.50	3.86	1.77	11.04

<sup>1</sup> Dimension "D" will never be exceeded, but may vary from values shown. When exact dimensions are required, shims up to .03" may be necessary.

<sup>2</sup> All rough casting dimensions may vary by .25" due to casting variations.

<sup>3</sup> Motor dimensions for other than "Type T" three phase TEFC motors,

refer to pages B-114 to B-116.

<sup>4</sup> Driven shaft entry can be from either side of the gear reducer housing by reversing positioning of the snap rings and washer illustrated.

<sup>5</sup> Output bore tolerance: +.0020", - .0000" for all diameters.

<sup>6</sup> Output key not supplied.

## Combined Finished Bore Hollow Shaft Face Mount - OtN34 - 35

Standard conduit box location will be opposite face mounting unless specified otherwise.

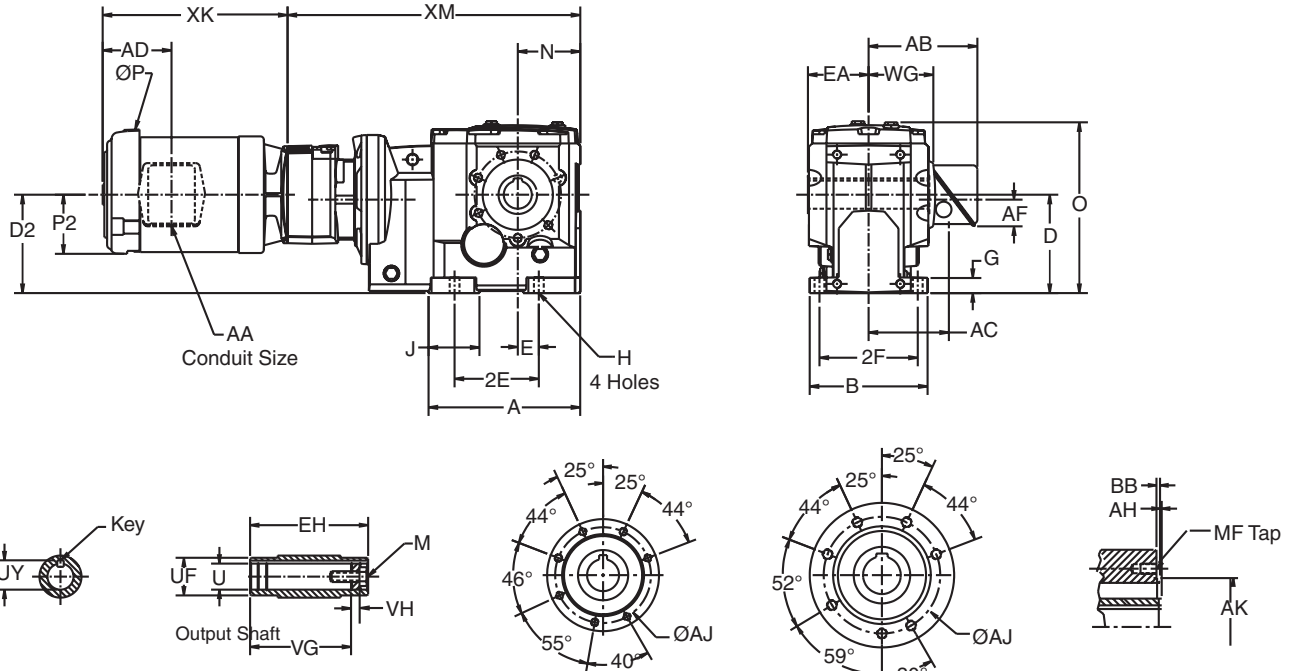

OtN Series

Gear Frame	Version	A	B	D <sup>1</sup>	D2	E	2E	2F	G	H	J	O	N	WG	XM
34	S2	10.13	7.87	7.09	5.57	1.57	5.91	6.50	1.07	.71	2.67	12.05	4.49	4.66	21.55
35	S2	11.92	8.66	8.35	6.56	2.17	7.09	7.09	1.18	.87	3.45	13.58	5.20	5.15	23.87

### Output Shaft

Gear Frame	Version	EA	EH	U <sup>6</sup>	UF	UY	VG	VH	Key <sup>5</sup>	M
34	S2	4.49	8.97	2.000	2.56	2.210	7.44	.79	1/2 X 7/16 X 2 5/8	5/8-11 X 1.75
35	S2	4.83	9.66	2.375	3.54	2.656	8.15	.94	5/8 X 5/8 X 3 5/8	3/4-10 X 2.00

### Face Mount

Gear Frame	Version	AH	AJ	AK	BB	MF
34	S2	.14	5.98	5.12	.28	M12-1.75 X 22
35	S2	.13	7.48	6.10	.28	M16-2.00 X 27

Motor Frame	Motor Type <sup>3</sup>	Gear Frame	P	P2	AA	AB	AC	AD	AF	XK
56	T	Any	7.31	3.31	.75	6.10	4.50	3.86	1.77	9.79
B56	T	Any	7.31	3.31	.75	6.10	4.50	3.86	1.77	11.04
143T, 145T	T	Any	7.31	3.31	.75	6.10	4.50	3.86	1.77	11.04
182T/184T	T	35	9.56	4.34	.75	6.10	4.50	5.13	1.77	14.04

<sup>1</sup> Dimension "D" will never be exceeded, but may vary from values shown. When exact dimensions are required, shims up to .03" may be necessary.

<sup>2</sup> All rough casting dimensions may vary by .25" due to casting variations.

<sup>3</sup> Motor dimensions for other than "Type T" three phase TEFC motors,

refer to pages B-114 to B-116.

<sup>4</sup> Driven shaft entry can be from either side of the gear reducer housing by reversing positioning of the snap rings and washer illustrated.

<sup>5</sup> Output key supplied only on frame 34 "S2" version.

<sup>6</sup> Output bore tolerance: +.0020", -.0000" for all diameters.

## Combined Finished Bore Hollow Shaft Face Mount - OtN36 - 38

Standard conduit box location will be opposite face mounting unless specified otherwise.

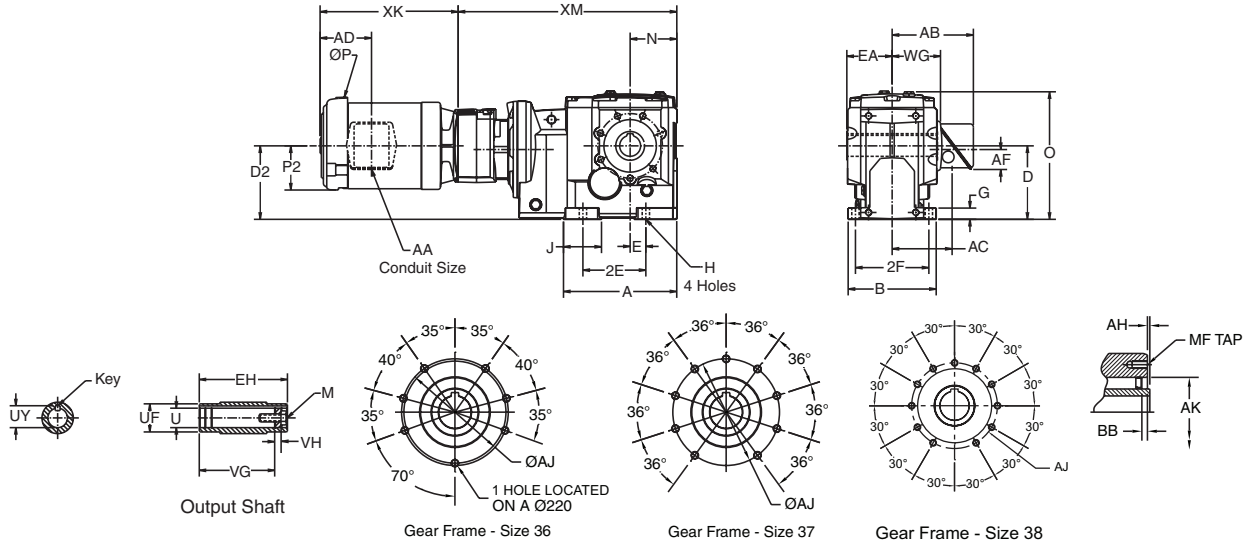

OtN Series

Gear Frame	Version	A	B	D <sup>1</sup>	D <sub>2</sub>	E	2E	2F	G	H	J	O	N	WG	XM
															56 -215T
36	S2	17.06	11.41	8.86	8.46	6.99	13.98	9.45	1.57	.87	3.87	16.26	8.74	6.78	31.04
37	S2	20.58	12.99	9.84	10.57	8.27	16.54	10.63	1.93	.94	4.78	18.29	10.04	7.44	36.37
38	S2	17.85	13.39	14.76	11.48	4.53	13.78	10.63	1.98	1.26	4.06	24.11	8.86	7.40	31.94

### Output Shaft

Gear Frame	Version	EA	EH	U <sup>3,5</sup>	UF	UY	VG	VH	Key <sup>6</sup>	M
36	S2	6.22	12.44	2.750	3.93	3.037	10.89	1.23	5/8 X 5/8 X 5 1/2	3/4-10 X 2.00
37	S2	6.80	13.59	3.625	4.72	4.019	11.90	1.23	7/8 X 7/8 X 5 1/2	3/4-10 X 2.00
38	S2	6.81	13.74	4.000	5.50	4.316	11.86	.92	1 X 1 X 6 1/2	1-8 X 2.25

### Face Mount

Gear Frame	Version	AH	AJ	AK	BB	MF
36	S2	.20	9.06	5.91	.28	M16-2.0 X 27
37	S2	.20	9.06	7.09	.28	M20-2.5 X 35
38	S2	.10	11.81	9.84	.20	M20-2.00 X 35

Motor Frame	Motor Type <sup>4</sup>	Gear Frame	P	P <sub>2</sub>	AA	AB	AC	AD	AF	XK
56	T	All	7.31	3.31	.75	6.10	4.50	3.86	1.77	9.79
B56	T	All	7.31	3.31	.75	6.10	4.50	3.86	1.77	11.04
143T, 145T	T	All	7.31	3.31	.75	6.10	4.50	3.86	1.77	11.04
182T/184T	T	All	9.56	4.34	.75	6.10	4.50	5.13	1.77	14.04
213T	T	All	11.25	5.06	1.00	8.42	7.17	5.60	2.42	16.15
215T	T	All	11.25	5.06	1.00	8.42	7.17	5.60	2.42	17.65

<sup>1</sup> Dimension "D" will never be exceeded, but may vary from values shown. When exact dimensions are required, shims up to .03" may be necessary.

<sup>2</sup> All rough casting dimensions may vary by .25" due to casting variations.

<sup>3</sup> Motor dimensions for other than "Type T" three phase TEFC motors,

refer to pages B-114 to B-116.

<sup>4</sup> Driven shaft entry can be from either side of the gear reducer housing by reversing positioning of the snap rings and washer illustrated.

<sup>5</sup> Output bore tolerance: +.0020", - .0000" for all diameters.

<sup>6</sup> Output key not supplied with reducer

## 2-Stage Finished Bore Hollow Shaft Flange Mount - OtN31 - 32

Standard conduit box location will be opposite flange unless specified otherwise.

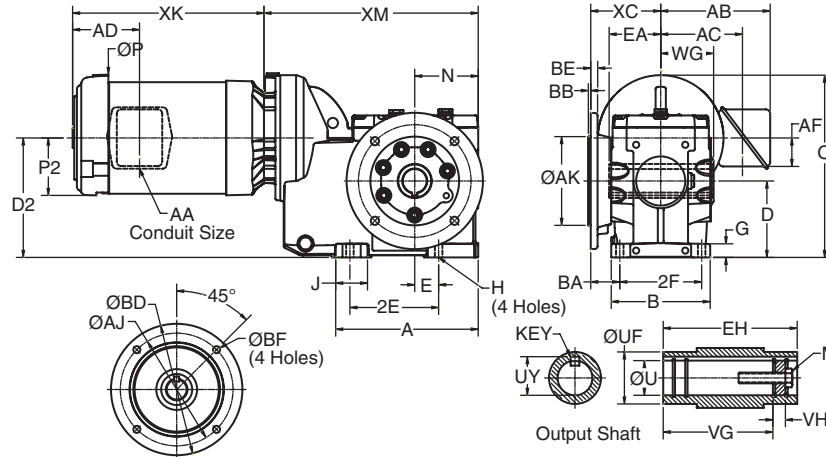

OtN Series

Gear Frame	Version	A	B	D'	D2	E	2E	2F	G	H	J	O	N	BA	WG	XC	XM
3132	S2	5.88	4.65	3.15	4.98	1.97	3.94	3.94	.56	.35	1.53	8.01	3.15	1.54	2.85	3.50	10.59
3242	S2	8.22	5.71	4.41	6.89	1.38	5.12	4.72	.79	.43	1.83	10.51	3.66	1.67	3.22	4.04	12.36

### Output Shaft

Gear Frame	Version	EA	EH	U <sup>5</sup>	UF	UY	VG	VH	Key <sup>6</sup>	M
3132	S2	2.56	5.12	1.250	1.77	1.372	4.31	.37	1/4 X 1/4 X 1 1/2	7/16-14 X 1.00
3242	S2	2.97	5.94	1.375	1.96	1.523	5.06	.37	5/16 X 5/16 1 13/16	1/2-13 X 1.00

### Output Flange

Gear Frame	Flange Code	AK	AJ	BB	BD	BE	BF
3132	5	4.331	5.12	.14	6.50	.39	.35
	6	3.740	4.53	.14	5.51	.44	.35
3242	5	5.118	6.50	.14	7.87	.39	.47
	6	7.087	8.46	.16	9.84	.47	.55

Motor Frame	Motor Type <sup>3</sup>	Gear Frame	P	P2	AA	AB	AC	AD	AF	XK
56	T	Any	7.31	3.31	.75	6.10	4.50	3.86	1.77	9.79
B56	T	Any	7.31	3.31	.75	6.10	4.50	3.86	1.77	11.04
143T, 145T	T	Any	7.31	3.31	.75	6.10	4.50	3.86	1.77	11.04
182T/184T	T	Any	9.56	4.34	.75	6.10	4.50	5.13	1.77	14.04
213T	T	32	11.25	5.06	1.00	8.42	7.17	5.60	2.42	16.15
215T	T	32	11.25	5.06	1.00	8.42	7.17	5.60	2.42	17.65

<sup>1</sup> Dimension "D" will never be exceeded, but may vary from values shown. When exact dimensions are required, shims up to .03" may be necessary.

<sup>2</sup> All rough casting dimensions may vary by .25" due to casting variations.

<sup>3</sup> Motor dimensions for other than "Type T" three phase TEFC motors, refer to pages B-114 to B-116.

<sup>4</sup> Driven shaft entry can be from either side of the gear reducer housing by reversing positioning of the snap rings and washer illustrated.

<sup>5</sup> Output bore tolerance: +.0020", -.0000" for all diameters.

<sup>6</sup> Output key not supplied.

## 3-Stage Finished Bore Hollow Shaft Flange Mount - OtN32 - 33

Standard conduit box location will be opposite flange unless specified otherwise.

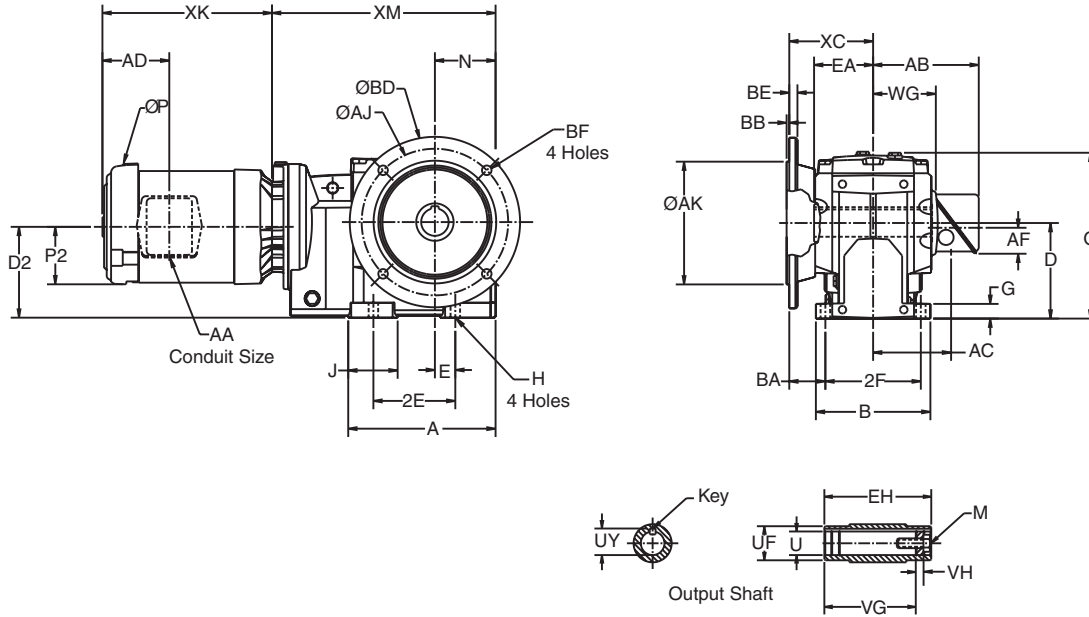

OtN Series

Gear Frame	Version	A	B	D <sup>1</sup>	D2	E	2E	2F	G	H	J	O	N	BA	WG	XC	XM
32	S2	7.81	5.71	4.41	3.78	1.38	5.12	4.71	.73	.43	2.34	8.09	3.03	1.81	3.22	4.04	10.98
33	S2	8.50	6.61	5.51	5.24	1.18	4.72	5.51	.85	.55	2.86	9.69	3.54	2.08	3.73	4.84	12.90

### Output Shaft

Gear Frame	Version	EA	EH	U <sup>5</sup>	UF	UY	VG	VH	Key	M
32	S2	2.98	5.96	1.375	1.96	1.523	5.20	.55	5/16 X 5/16 X 1 13/16	1/2-13 X 1.00
33	S2	3.47	6.94	1.500	2.16	1.674	5.96	.55	3/8 X 3/8 X 2 1/4	5/8-11 X 1.75

### Output Flange

Gear Frame	Flange Code	AK	AJ	BB	BD	BE	BF
32	5	5.118	6.50	.14	7.87	.39	.47
	6	7.087	8.46	.16	9.84	.47	.55
33	5	7.087	8.46	.16	9.84	.47	.55
	6	9.055	10.43	.16	11.81	.47	.55

Motor Frame	Motor Type <sup>3</sup>	Gear Frame	P	P2	AA	AB	AC	AD	AF	XK
56	T	Any	7.31	3.31	.75	6.10	4.50	3.86	1.77	9.79
B56	T	Any	7.31	3.31	.75	6.10	4.50	3.86	1.77	11.04
143T, 145T	T	Any	7.31	3.31	.75	6.10	4.50	3.86	1.77	11.04
182T/184T	T	Any	9.56	4.34	.75	6.10	4.50	5.13	1.77	14.04
213T	T	33	11.25	5.06	1.00	8.42	7.17	5.60	2.42	16.15
215T	T	33	11.25	5.06	1.00	8.42	7.17	5.60	2.42	17.65

<sup>1</sup> Dimension "D" will never be exceeded, but may vary from values shown. When exact dimensions are required, shims up to .03" may be necessary.

<sup>2</sup> All rough casting dimensions may vary by .25" due to casting variations.

<sup>3</sup> Motor dimensions for other than "Type T" three phase TEFC motors, refer to pages B-114 to B-116.

<sup>4</sup> Driven shaft entry can be from either side of the gear reducer housing by reversing positioning of the snap rings and washer illustrated.

<sup>5</sup> Output bore tolerance: +.0020", -.0000" for all diameters.

## 3-Stage Finished Bore Hollow Shaft Flange Mount - OtN34 - 35

Standard conduit box location will be opposite flange unless specified otherwise.

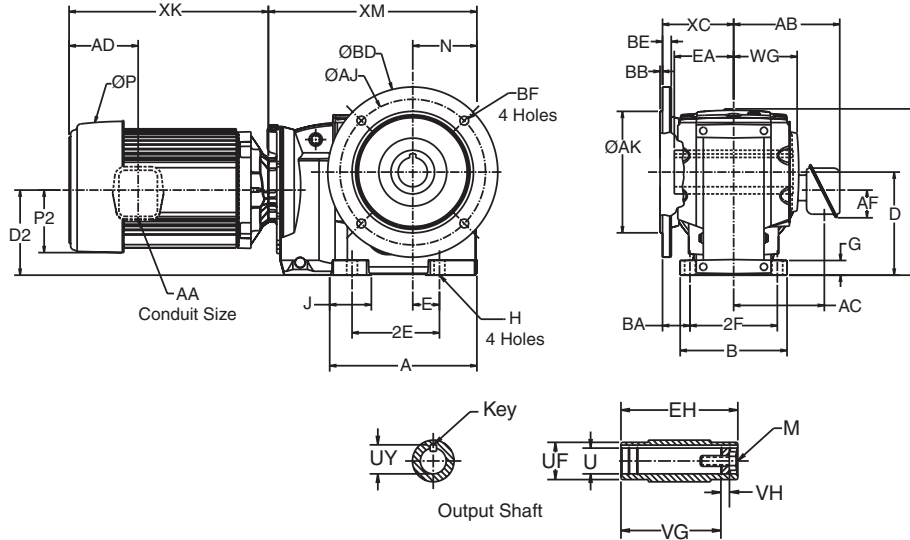

OtN Series

Gear Frame	Version	A	B	D <sup>1</sup>	D2	E	2E	2F	G	H	J	O	N	BA	WG	XC	XM	
																	56T-215T	254T-286T
34	S2	10.13	7.87	7.09	5.90	1.57	5.91	6.50	1.07	.71	2.67	12.05	4.49	1.93	4.66	5.18	14.56	-
35	S2	11.92	8.66	8.35	6.89	2.17	7.09	7.09	1.18	.87	3.45	13.58	5.20	2.22	5.15	5.76	16.90	17.25

### Output Shaft

Gear Frame	Version	EA	EH	U <sup>6</sup>	UF	UY	VG	VH	Key <sup>5</sup>	M
34	S2	4.49	8.97	2.000	2.56	2.210	7.44	.79	1/2 X 7/16 X 2 5/8	5/8-11 X 1.75
35	S2	4.83	9.66	2.375	3.54	2.656	8.15	.94	5/8 X 5/8 X 3 5/8	3/4-10 X 2.00

### Output Flange

Gear Frame	Flange Code	AK	AJ	BB	BD	BE	BF
34	5	9.055	10.43	.16	11.80	.59	.55
	6	9.842	11.80	.16	13.77	.59	.71
35	5	9.842	11.80	.20	13.77	.71	.71
	6	11.810	13.77	.20	15.75	.71	.71

Motor Frame	Motor Type <sup>3</sup>	Gear Frame	P	P2	AA	AB	AC	AD	AF	XK
56	T	Any	7.31	3.31	.75	6.10	4.50	3.86	1.77	9.79
B56	T	Any	7.31	3.31	.75	6.10	4.50	3.86	1.77	11.04
143T, 145T	T	Any	7.31	3.31	.75	6.10	4.50	3.86	1.77	11.04
182T/184T	T	Any	9.56	4.34	.75	6.10	4.50	5.13	1.77	14.04
213T	T	Any	11.25	5.06	1.00	8.42	7.17	5.60	2.42	16.15
215T	T	Any	11.25	5.06	1.00	8.42	7.17	5.60	2.42	17.65
254T	T	34	13.38	6.00	1.25	9.79	7.68	8.29	1.81	20.58
	T	35	13.38	6.00	1.25	9.79	7.68	8.29	1.81	19.61
256T	T	34	13.38	6.00	1.25	9.79	7.68	8.29	1.81	22.33
	T	35	13.38	6.00	1.25	9.79	7.68	8.29	1.81	21.36
284T	T	35	13.38	6.00	1.50	10.58	8.18	8.29	2.13	21.86
286T	T	35	13.38	6.00	1.50	10.33	7.93	8.29	2.13	23.36

<sup>1</sup> Dimension "D" will never be exceeded, but may vary from values shown. When exact dimensions are required, shims up to .03" may be necessary.

<sup>2</sup> All rough casting dimensions may vary by .25" due to casting variations.

<sup>3</sup> Motor dimensions for other than "Type T" three phase TEFC motors,

refer to pages B-114 to B-116.

<sup>4</sup> Driven shaft entry can be from either side of the gear reducer housing by reversing positioning of the snap rings and washer illustrated.

<sup>5</sup> Output key supplied on frame 34 only.

<sup>6</sup> Output bore tolerance: +.0020", - .0000" for all diameters.

## 3-Stage Finished Bore Hollow Shaft Flange Mount - OtN36 - 38

Standard conduit box location will be opposite flange unless specified otherwise.

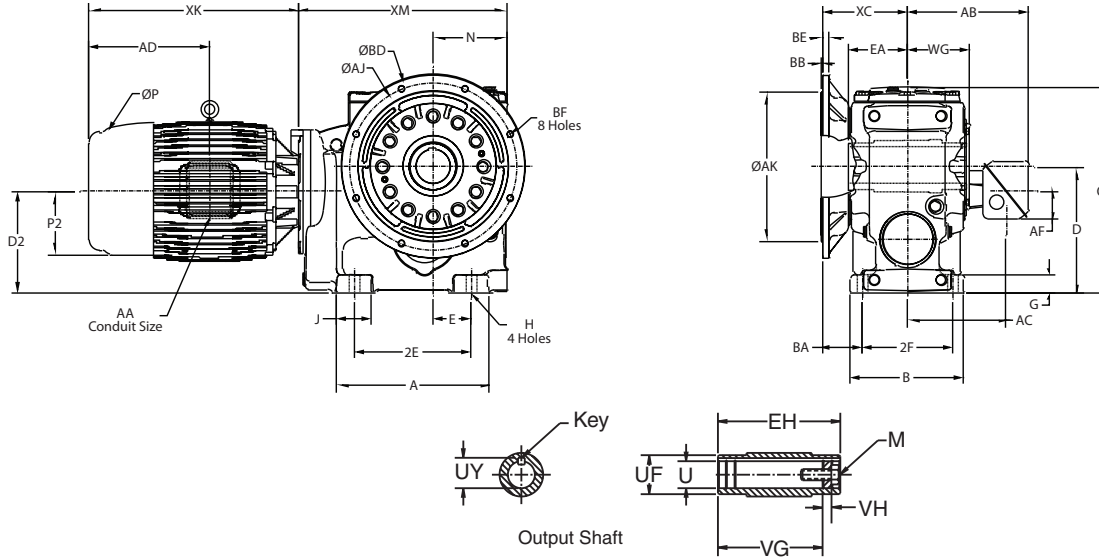

Gear Frame	Version	A	B	D <sup>1</sup>	D2	E	2E	2F	G	H	J	O	N	BA	WG	XC	XM		
																	182T/184T	213T-215T	254T-UP
36	S2	17.06	11.41	8.86	8.86	6.99	13.98	9.45	1.57	.87	3.87	16.26	8.74	4.45	6.78	9.17	23.38	23.38	23.73
37	S2	20.58	12.99	9.84	10.98	8.27	16.54	10.63	1.93	.94	4.78	18.29	10.04	4.45	7.44	9.76	-	29.06	29.41
38	S2	17.85	13.39	14.76	11.87	4.53	13.78	10.63	1.98	1.26	4.06	24.11	8.86	4.65	7.40	9.96	-	24.29	24.64

### Output Shaft

Gear Frame	Version	EA	EH	U <sup>4,5</sup>	UF	UY	VG	VH	Key <sup>6</sup>	M
36	S2	6.22	12.44	2.750	3.93	3.037	10.89	1.23	5/8 X 5/8 X 5 1/2	3/4-10 X 2.00
37	S2	6.80	13.59	3.625	4.72	4.019	11.90	1.23	7/8 X 7/8 X 5 1/2	3/4-10 X 2.00
38	S2	6.81	13.74	4.000	5.50	4.316	11.86	.92	1 X 1 X 6 1/2	1-8 X 2.25

### Output Flange

Gear Frame	Flange Code	AJ	AK	BB	BD	BE	BF
36 & 37	5	13.78	15.75	.236	17.70	.79	.71
	6	17.72	19.68	.236	21.65	.63	.87
38	5	17.72	19.69	.200	21.65	.79	.69
	6	21.65	23.62	.236	25.98	.63	.87

Motor Frame	Motor Type <sup>3</sup>	Gear Frame	P	P2	AA	AB	AC	AD	AF	XK
182T/184T	T	36	9.56	4.34	.75	6.10	4.50	5.13	1.77	14.04
213T	T	All	11.25	5.06	1.00	8.42	7.17	5.60	2.42	16.15
215T	T	All	11.25	5.06	1.00	8.42	7.17	5.60	2.42	17.65
254T	T	All	13.38	6.00	1.25	9.79	7.68	8.29	1.81	19.61
256T	T	All	13.38	6.00	1.25	9.79	7.68	8.29	1.81	21.36
284T/286T	T	All	14.62	7.29	1.50	11.33	8.51	12.44	2.63	24.26
324T/326T	T	All	17.2	7.78	2.00	14.99	11.34	14.16	3.63	24.96

<sup>1</sup> Dimension "D" will never be exceeded, but may vary from values shown. When exact dimensions are required, shims up to .03" may be necessary.

<sup>2</sup> All rough casting dimensions may vary by .25" due to casting variations.

<sup>3</sup> Motor dimensions for other than "Type T" three phase TEFC motors,

refer to pages B-114 to B-116.

<sup>4</sup> Driven shaft entry can be from either side of the gear reducer housing by reversing positioning of the snap rings and washer illustrated.

<sup>5</sup> Output bore tolerance: +.0020", -.0000" for all diameters.

<sup>6</sup> Output shaft key not supplied.



## Combined Finished Bore Hollow Shaft Flange Mount - OtN32 - 33

Standard conduit box location will be opposite flange unless specified otherwise.

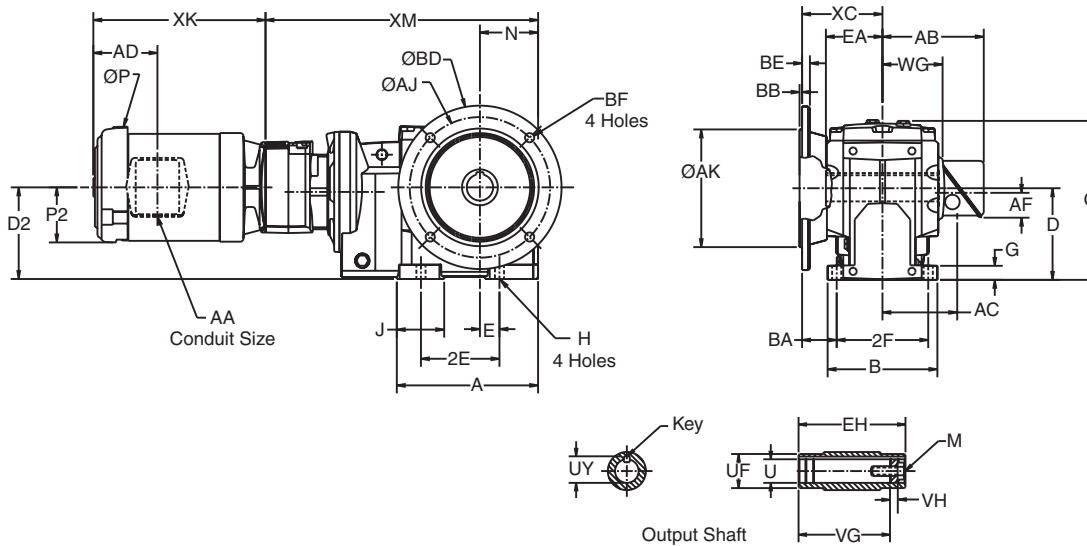

OtN Series

Gear Frame	Version	A	B	D'	D2	E	2E	2F	G	H	J	O	N	BA	WG	XC	XM
32	S2	7.81	5.71	4.41	4.06	1.38	5.12	4.71	.73	.43	2.34	8.09	3.03	1.81	3.22	4.04	14.49
33	S2	8.50	6.61	5.51	4.91	1.18	4.72	5.51	.85	.55	2.86	9.69	3.54	2.08	3.73	4.84	19.90

### Output Shaft

Gear Frame	Version	EA	EH	U <sup>5</sup>	UF	UY	VG	VH	Key <sup>6</sup>	M
32	S2	2.98	5.96	1.375	1.96	1.523	5.20	.55	5/16 X 5/16 X 1 13/16	1/2-13 X 1.00
33	S2	3.47	6.94	1.500	2.16	1.674	5.96	.55	3/8 X 3/8 X 2 1/4	5/8-11 X 1.75

### Output Flange

Gear Frame	Flange Code	AK	AJ	BB	BD	BE	BF
32	5	5.118	6.50	.14	7.87	.39	.47
	6	7.087	8.46	.16	9.84	.47	.55
33	5	7.087	8.46	.16	9.84	.47	.55
	6	9.055	10.43	.16	11.81	.47	.55

Motor Frame	Motor Type <sup>3</sup>	Gear Frame	P	P2	AA	AB	AC	AD	AF	XK
56	T	32	7.31	3.31	.75	6.10	4.50	3.86	1.77	10.37
	T	33	7.31	3.31	.75	6.10	4.50	3.86	1.77	9.79
B56	T	32	7.31	3.31	.75	6.10	4.50	3.86	1.77	11.62
	T	33	7.31	3.31	.75	6.10	4.50	3.86	1.77	11.04
143T, 145T	T	33	7.31	3.31	.75	6.10	4.50	3.86	1.77	11.04

<sup>1</sup> Dimension "D" will never be exceeded, but may vary from values shown. When exact dimensions are required, shims up to .03" may be necessary.

<sup>2</sup> All rough casting dimensions may vary by .25" due to casting variations.

<sup>3</sup> Motor dimensions for other than "Type T" three phase TEFC motors,

refer to pages B-114 to B-116.

<sup>4</sup> Driven shaft entry can be from either side of the gear reducer housing by reversing positioning of the snap rings and washer illustrated.

<sup>5</sup> Output bore tolerance: +.0020", - .0000" for all diameters.

<sup>6</sup> Output key not supplied.

## Combined Finished Bore Hollow Shaft Flange Mount - OtN34 - 35

Standard conduit box location will be opposite flange unless specified otherwise.

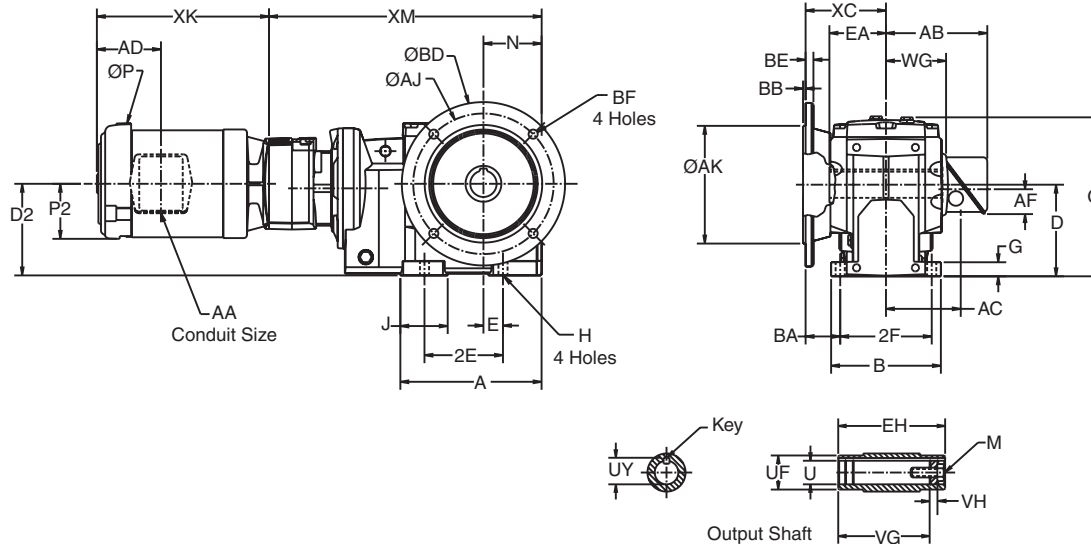

Gear Frame	Version	A	B	D <sup>1</sup>	D2	E	2E	2F	G	H	J	O	N	BA	WG	XC	XM
34	S2	10.13	7.87	7.09	5.57	1.57	5.91	6.50	1.07	.71	2.67	12.05	4.49	1.93	4.66	5.18	21.55
35	S2	11.92	8.66	8.35	6.56	2.17	7.09	7.09	1.18	.87	3.45	13.58	5.20	2.22	5.15	5.76	23.87

### Output Shaft

Gear Frame	Version	EA	EH	U <sup>6</sup>	UF	UY	VG	VH	Key <sup>5</sup>	M
34	S2	4.49	8.97	2.000	2.56	2.210	7.44	.79	1/2 X 7/16 X 2 5/8	5/8-11 X 1.75
35	S2	4.83	9.66	2.375	3.54	2.656	8.15	.94	5/8 X 5/8 X 3 5/8	3/4-10 X 2.00

### Output Flange

Gear Frame	Flange Code	AK	AJ	BB	BD	BE	BF
34	5	9.055	10.43	.16	11.80	.59	.55
	6	9.842	11.80	.16	13.77	.59	.71
35	5	9.842	11.80	.20	13.77	.71	.71
	6	11.810	13.77	.20	15.75	.71	.71

Motor Frame	Motor Type <sup>3</sup>	Gear Frame	P	P2	AA	AB	AC	AD	AF	XK
56	T	Any	7.31	3.31	.75	6.10	4.50	3.86	1.77	9.79
B56	T	Any	7.31	3.31	.75	6.10	4.50	3.86	1.77	11.04
143T, 145T	T	Any	7.31	3.31	.75	6.10	4.50	3.86	1.77	11.04
182T/184T	T	35	9.56	4.34	.75	6.10	4.50	5.13	1.77	14.04

<sup>1</sup> Dimension "D" will never be exceeded, but may vary from values shown. When exact dimensions are required, shims up to .03" may be necessary.

<sup>2</sup> All rough casting dimensions may vary by .25" due to casting variations.

<sup>3</sup> Motor dimensions for other than "Type T" three phase TEFC motors,

refer to pages B-114 to B-116.

<sup>4</sup> Driven shaft entry can be from either side of the gear reducer housing by reversing positioning of the snap rings and washer illustrated.

<sup>5</sup> Output key supplied only on frame 34 "S2" version.

<sup>6</sup> Output bore tolerance: +.0020", - .0000" for all diameters.

## Combined Finished Bore Hollow Shaft Flange Mount - OtN36 - 38

Standard conduit box location will be opposite flange unless specified otherwise.

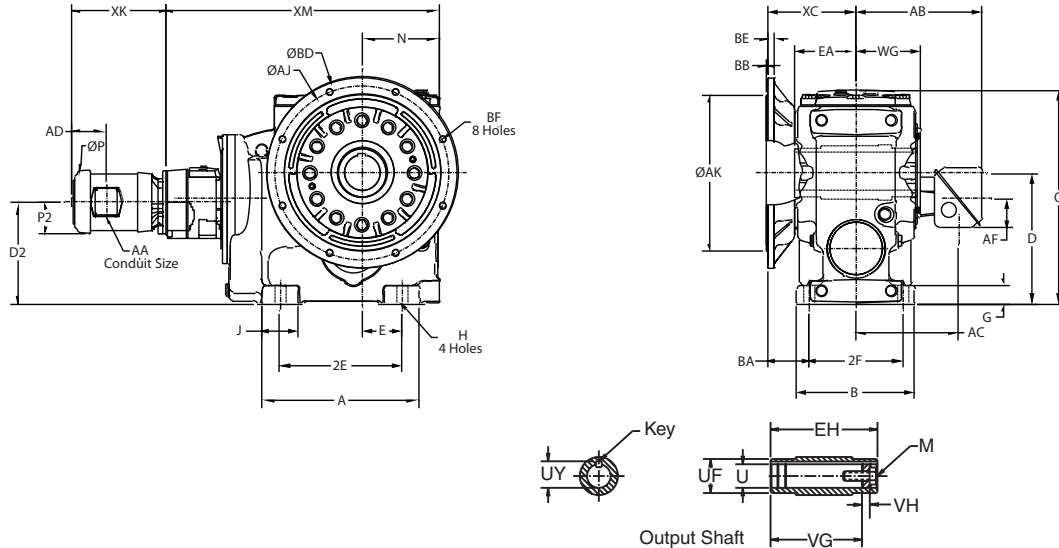

# OtN Series

Gear Frame	Version	A	B	D <sup>1</sup>	D2	E	2E	2F	G	H	J	O	N	BA	WG	XC	XM
																	56 -215T
36	S2	17.06	11.41	8.86	8.46	6.99	13.98	9.45	1.57	.87	3.87	16.26	8.74	4.45	6.78	9.17	31.04
37	S2	20.58	12.99	9.84	10.57	8.27	16.54	10.63	1.93	.94	4.78	18.29	10.04	4.45	7.44	9.76	36.37
38	S2	17.85	13.39	14.76	11.48	4.53	13.78	10.63	1.98	1.26	4.06	24.11	8.86	4.65	7.40	9.96	31.94

### Output Shaft

Gear Frame	Version	EA	EH	U <sup>4,5</sup>	UF	UY	VG	VH	Key <sup>6</sup>	M
36	S2	6.22	12.44	2.750	3.93	3.037	10.89	1.23	5/8 X 5/8 X 5 1/2	3/4-10 X 2.00
37	S2	6.80	13.59	3.625	4.72	4.019	11.90	1.23	7/8 X 7/8 X 5 1/2	3/4-10 X 2.00
38	S2	6.81	13.74	4.000	5.50	4.316	11.86	.92	1 X 1 X 6 1/2	1-8 X 2.25

### Output Flange

Gear Frame	Flange Code	AJ	AK	BB	BD	BE	BF
36 & 37	5	13.78	15.75	.236	17.70	.79	.71
	6	17.72	19.68	.236	21.65	.63	.87
38	5	17.72	19.69	.200	21.65	.79	.69
	6	21.65	23.62	.236	25.98	.63	.87

Motor Frame	Motor Type <sup>4</sup>	Gear Frame	P	P2	AA	AB	AC	AD	AF	XK
56	T	All	7.31	3.31	.75	6.10	4.50	3.86	1.77	9.79
B56	T	All	7.31	3.31	.75	6.10	4.50	3.86	1.77	11.04
143T, 145T	T	All	7.31	3.31	.75	6.10	4.50	3.86	1.77	11.04
182T/184T	T	All	9.56	4.34	.75	6.10	4.50	5.13	1.77	14.04
213T	T	All	11.25	5.06	1.00	8.42	7.17	5.60	2.42	16.15
215T	T	All	11.25	5.06	1.00	8.42	7.17	5.60	2.42	17.65

<sup>1</sup> Dimension "D" will never be exceeded, but may vary from values shown. When exact dimensions are required, shims up to .03" may be necessary.

<sup>2</sup> All rough casting dimensions may vary by .25" due to casting variations.

<sup>3</sup> Motor dimensions for other than "Type T" three phase TEFC motors,

refer to pages B-114 to B-116.

<sup>4</sup> Driven shaft entry can be from either side of the gear reducer housing by reversing positioning of the snap rings and washer illustrated.

<sup>5</sup> Output bore tolerance: +.0020", -.0000" for all diameters.

<sup>6</sup> Output key not supplied with unit

## 2-Stage Bushed Shaft Mount OtN31 - 32

Standard conduit box location will be F1 unless specified otherwise.

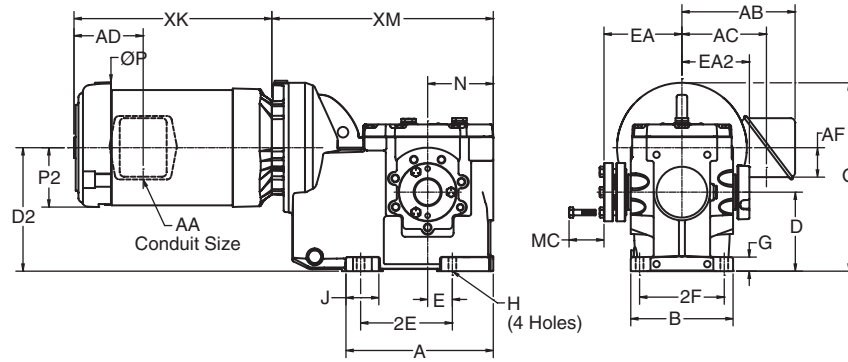

OtN Series

Gear Frame	Version	A	B	D <sup>1</sup>	D2	E	2E	2F	G	H	J	O	N	XM
3132	S2	5.88	4.65	3.15	4.98	1.97	3.94	3.94	.56	.35	1.53	8.01	3.15	10.59
3242	S2	8.22	5.71	4.41	6.89	1.38	5.12	4.72	.79	.43	1.83	10.51	3.66	12.36

### Output Shaft

Gear Frame	Version	EA	EA2	MC <sup>5</sup>	Bushing Bores <sup>4</sup>	
					Min.	Max.
3132	S2	4.25	3.80	1.50	1	1 5/16
3242	S2	4.85	4.27	1.75	1 5/16	1 7/16

Motor Frame	Motor Type <sup>3</sup>	Gear Frame	P	P2	AA	AB	AC	AD	AF	XK
56	T	Any	7.31	3.31	.75	6.10	4.50	3.86	1.77	9.79
B56	T	Any	7.31	3.31	.75	6.10	4.50	3.86	1.77	11.04
143T, 145T	T	Any	7.31	3.31	.75	6.10	4.50	3.86	1.77	11.04
182T/184T	T	Any	9.56	4.34	.75	6.10	4.50	5.13	1.77	14.04
213T	T	32	11.25	5.06	1.00	8.42	7.17	5.60	2.42	16.15
215T	T	32	11.25	5.06	1.00	8.42	7.17	5.60	2.42	17.65

<sup>1</sup> Dimension "D" will never be exceeded, but may vary from values shown. When exact dimensions are required, shims up to .03" may be necessary.

<sup>2</sup> All rough casting dimensions may vary by .25" due to casting variations.

<sup>3</sup> Motor dimensions for other than "Type T" three phase TEFC motors, refer to pages B-114 to B-116.

<sup>4</sup> Refer to page B-26 by gear frame for listing of all inch and metric bushing bore sizes available.

<sup>5</sup> The "MC" dimension shows spacing required to install or remove the bushing from the reducer.

<sup>6</sup> Bushing and dust cap can be installed opposite of how they are shown above.

<sup>7</sup> Driven shaft entry can be from either side of the gear reducer housing. Refer to Installation Manual for requirements.

<sup>8</sup> For details of the torque arm kit, refer to page B-22.

## 3-Stage Taper Bushed Shaft Mount OtN32 - 33

Standard conduit box location will be F1 unless specified otherwise.

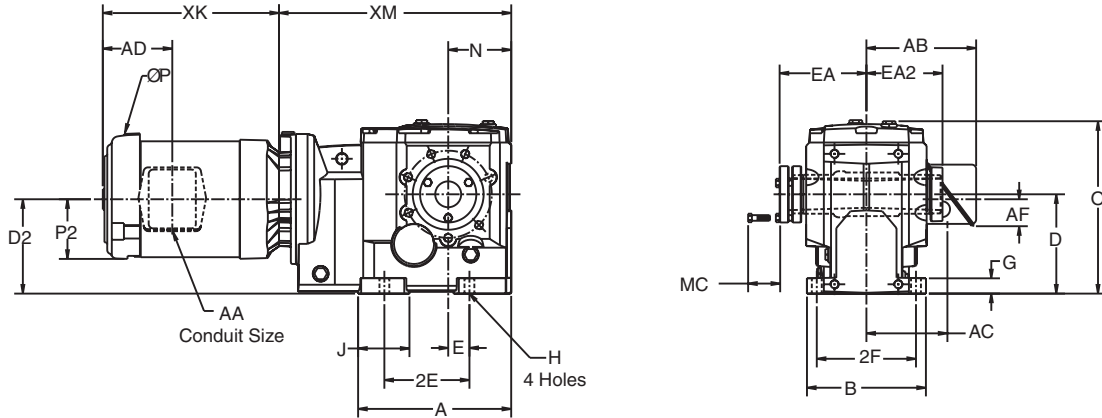

# OtN Series

Gear Frame	Version	A	B	D <sup>1</sup>	D <sub>2</sub>	E	2E	2F	G	H	J	O	N	XM
32	S2	7.81	5.71	4.41	37.78	1.38	5.12	4.71	.73	.43	2.34	8.09	3.03	10.98
33 (A)	S2	8.50	6.61	5.51	5.24	1.18	4.72	5.51	.85	.55	2.86	9.69	3.54	12.90

### Output Shaft

Gear Frame	Version	EA	EA <sub>2</sub>	MC <sup>5</sup>	Bushing Bores <sup>4</sup>	
					Min.	Max.
32	S2	4.85	4.27	1.75	1 5/16	1 7/16
33	S2	4.82	4.23	1.75	1 5/16	1 7/16
33A	S2	5.76	5.18	1.88	1 7/16	1 15/16

Motor Frame	Motor Type <sup>3</sup>	Gear Frame	P	P <sub>2</sub>	AA	AB	AC	AD	AF	XK
56	T	Any	7.31	3.31	.75	6.10	4.50	3.86	1.77	9.79
B56	T	Any	7.31	3.31	0.75	6.10	4.50	3.86	1.77	11.04
143T, 145T	T	Any	7.31	3.31	0.75	6.10	4.50	3.86	1.77	11.04
182T/184T	T	Any	9.56	4.34	.75	6.10	4.50	5.13	1.77	14.04
213T	T	33 (A)	11.25	5.06	1.00	8.42	7.17	5.60	2.42	16.15
215T	T	33 (A)	11.25	5.06	1.00	8.42	7.17	5.60	2.42	17.65

<sup>1</sup> Dimension "D" will never be exceeded, but may vary from values shown. When exact dimensions are required, shims up to .03" may be necessary.

<sup>2</sup> All rough casting dimensions may vary by .25" due to casting variations.

<sup>3</sup> Motor dimensions for other than "Type T" three phase TEFC motors, refer to pages B-114 to B-116.

<sup>4</sup> Refer to page B-26 by gear frame for listing of all inch and metric bushing bore sizes available.

<sup>5</sup> The "MC" dimension shows spacing required to install or remove the bushing from the reducer.

<sup>6</sup> Bushing and dust cap can be installed opposite of how they are shown above.

<sup>7</sup> Driven shaft entry can be from either side of the gear reducer housing. Refer to Installation Manual for requirements.

<sup>8</sup> For details of the torque arm kit, refer to page B-22.

## 3-Stage Taper Bushed Shaft Mount OtN34 - 35

Standard conduit box location will be F1 unless specified otherwise.

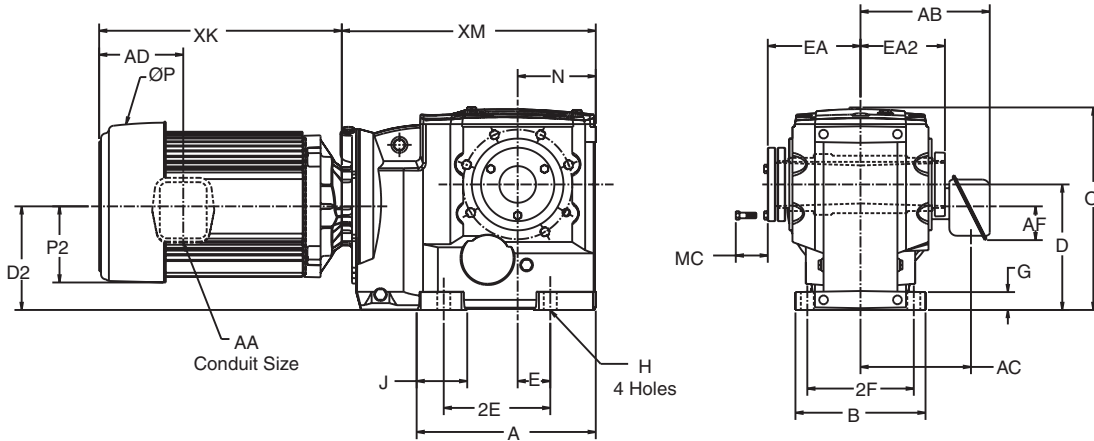

Gear Frame	Version	A	B	D <sup>1</sup>	D2	E	2E	2F	G	H	J	O	N	XM	
														56-215T	254T-286T
34	S2	10.13	7.87	7.09	5.90	1.57	5.91	6.50	1.07	.71	2.67	12.05	4.49	14.56	-
35	S2	11.92	8.66	8.35	6.89	2.17	7.09	7.09	1.18	.87	3.45	13.58	5.20	16.90	17.25

### Output Shaft

Gear Frame	Version	EA	EA2	MC <sup>5</sup>	Bushing Bores <sup>4</sup>	
					Min.	Max
34	S2	5.84	5.27	1.88	1 11/16	1 15/16
35	S2	6.17	5.62	1.88	2	2 7/16

Motor Frame	Motor Type <sup>3</sup>	Gear Frame	P	P2	AA	AB	AC	AD	AF	XK
56	T	Any	7.31	3.31	.75	6.10	4.50	3.86	1.77	9.79
B56	T	Any	7.31	3.31	.75	6.10	4.50	3.86	1.77	11.04
143T, 145T	T	Any	7.31	3.31	.75	6.10	4.50	3.86	1.77	11.04
182T/184T	T	Any	9.56	4.34	.75	6.10	4.50	5.13	1.77	14.04
213T	T	Any	11.25	5.06	1.00	8.42	7.17	5.60	2.42	16.15
215T	T	Any	11.25	5.06	1.00	8.42	7.17	5.60	2.42	17.65
254T	T	34	13.38	6.00	1.25	9.79	7.68	8.29	1.81	20.58
	T	35	13.38	6.00	1.25	9.79	7.68	8.29	1.81	19.61
256T	T	34	13.38	6.00	1.25	9.79	7.68	8.29	1.81	22.33
	T	35	13.38	6.00	1.25	9.79	7.68	8.29	1.81	21.36
284T/286T	T	35	14.62	7.29	1.50	11.33	8.51	12.44	2.63	24.26

<sup>1</sup> Dimension "D" will never be exceeded, but may vary from values shown. When exact dimensions are required, shims up to .03" may be necessary.

<sup>2</sup> All rough casting dimensions may vary by .25" due to casting variations.

<sup>3</sup> Motor dimensions for other than "Type T" three phase TEFC motors, refer to pages B-114 to B-116.

<sup>4</sup> Refer to page B-26 by gear frame for listing of all inch and metric bushing bore sizes available.

<sup>5</sup> The "MC" dimension shows spacing required to install or remove the bushing from the reducer.

<sup>6</sup> Bushing and dust cap can be installed opposite of how they are shown above.

<sup>7</sup> Driven shaft entry can be from either side of the gear reducer housing. Refer to Installation Manual for requirements.

<sup>8</sup> For details of the torque arm kit, refer to page B-22.

## 3-Stage Taper Bushed Shaft Mount OtN36 - 38

Standard conduit box location will be F1 unless specified otherwise.

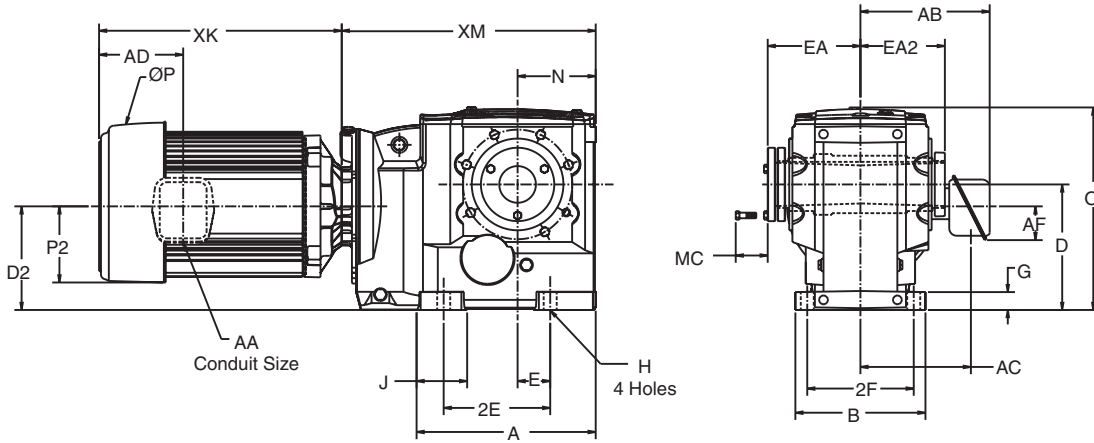

OtN Series

Gear Frame	Version	A	B	D <sup>1</sup>	D2	E	2E	2F	G	H	J	O	N	XM		
														182T/184T	213T-215T	254T-UP
36	S2	17.06	11.41	8.86	8.86	6.99	13.98	9.45	1.57	.87	3.87	16.26	8.74	23.38	23.38	23.73
37	S2	20.58	12.99	9.84	10.98	8.27	16.54	10.63	1.93	.94	4.78	18.29	10.04	-	29.06	29.41
38	S2	17.85	13.39	14.76	11.87	4.53	13.78	10.63	1.98	1.26	4.06	24.11	8.86	-	24.29	24.64

### Output Shaft

Gear Frame	Version	EA	EA2	MC <sup>5</sup>	Bushing Bores <sup>4</sup>	
					Min.	Max.
36	S2	6.81	7.83	1.88	2 7/16	2 15/16
37	S2	9.50	8.86	2.25	2 7/8	3 7/16
38	S2	8.66	8.08	2.75	2 15/16	3 15/16

Motor Frame	Motor Type <sup>3</sup>	Gear Frame	P	P2	AA	AB	AC	AD	AF	XK
182T/184T	T	36	9.56	4.34	.75	6.10	4.50	5.13	1.77	14.04
213T	T	All	11.25	5.06	1.00	8.42	7.17	5.60	2.42	16.15
215T	T	All	11.25	5.06	1.00	8.42	7.17	5.60	2.42	17.65
254T	T	All	13.38	6.00	1.25	9.79	7.68	8.29	1.81	19.61
256T	T	All	13.38	6.00	1.25	9.79	7.68	8.29	1.81	21.36
284T/286T	T	All	14.62	7.29	1.50	11.33	8.51	12.44	2.63	24.26
324T/326T	T	All	17.2	7.78	2.00	14.99	11.34	14.16	3.63	27.36

<sup>1</sup> Dimension "D" will never be exceeded, but may vary from values shown. When exact dimensions are required, shims up to .03" may be necessary.  
<sup>2</sup> All rough casting dimensions may vary by .25" due to casting variations.  
<sup>3</sup> Motor dimensions for other than "Type T" three phase TEFC motors, refer to pages B-114 to B-116.  
<sup>4</sup> Refer to page B-26 by gear frame for listing of all inch and metric bushing bore sizes available.

<sup>5</sup> The "MC" dimension shows spacing required to install or remove the bushing from the reducer.  
<sup>6</sup> Bushing and dust cap can be installed opposite of how they are shown above.  
<sup>7</sup> Driven shaft entry can be from either side of the gear reducer housing. Refer to Installation Manual for requirements.  
<sup>8</sup> For details of the torque arm kit, refer to pages B-22 and B-23.



## Combined Taper Bushed Shaft Mount OtN32 - 33

Standard conduit box location will be F1 unless specified otherwise.

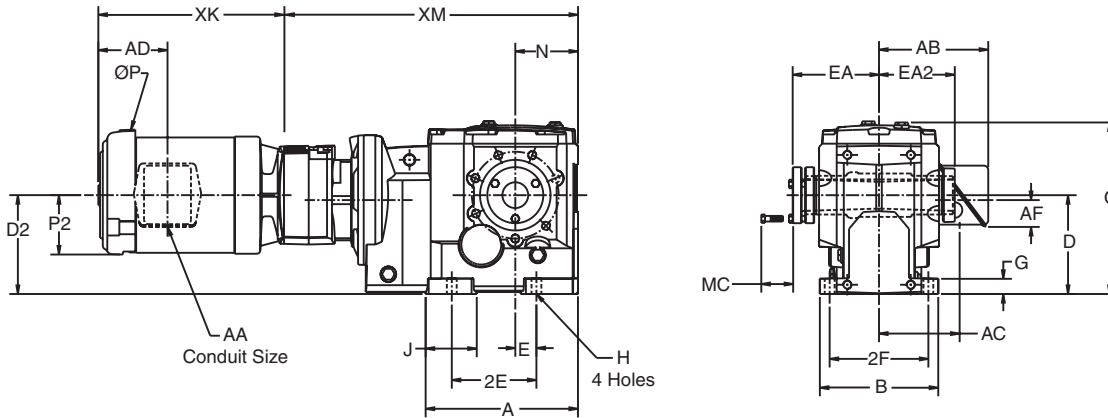

Gear Frame	Version	A	B	D <sup>1</sup>	D2	E	2E	2F	G	H	J	O	N	XM
32	S2	7.81	5.71	4.41	4.06	1.38	5.12	4.71	.73	.43	2.34	8.09	3.03	14.49
33 (A)	S2	8.50	6.61	5.51	4.91	1.18	4.72	5.51	.85	.55	2.86	9.69	3.54	19.90

### Output Shaft

Gear Frame	Version	EA	EA2	MC <sup>5</sup>	Bushing Bores <sup>4</sup>	
					Min.	Max.
32	S2	4.85	4.27	1.75	1 5/16	1 7/16
33	S2	4.82	4.23	1.75	1 5/16	1 7/16
33A	S2	5.76	5.18	1.88	1 7/16	1 15/16

Motor Frame	Motor Type <sup>3</sup>	Gear Frame	P	P2	AA	AB	AC	AD	AF	XK
56	T	32	7.31	3.31	.75	6.10	4.50	3.86	1.77	10.37
	T	33 (A)	7.31	3.31	.75	6.10	4.50	3.86	1.77	9.79
B56	T	32	7.31	3.31	.75	6.10	4.50	3.86	1.77	11.62
	T	33 (A)	7.31	3.31	.75	6.10	4.50	3.86	1.77	11.04
143T, 145T	T	33 (A)	7.31	3.31	.75	6.10	4.50	3.86	1.77	11.04

<sup>1</sup> Dimension "D" will never be exceeded, but may vary from values shown. When exact dimensions are required, shims up to .03" may be necessary.

<sup>2</sup> All rough casting dimensions may vary by .25" due to casting variations.

<sup>3</sup> Motor dimensions for other than "Type T" three phase TEFC motors, refer to pages B-114 to B-116.

<sup>4</sup> Refer to page B-26 by gear frame for listing of all inch and metric bushing bore sizes available.

<sup>5</sup> The "MC" dimension shows spacing required to install or remove the bushing from the reducer.

<sup>6</sup> Bushing and dust cap can be installed opposite of how they are shown above.

<sup>7</sup> Driven shaft entry can be from either side of the gear reducer housing. Refer to Installation Manual for requirements.

<sup>8</sup> For details of the torque arm kit, refer to page B-22.

## Combined Taper Bushed Shaft Mount OtN34 - 35

Standard conduit box location will be F1 unless specified otherwise.

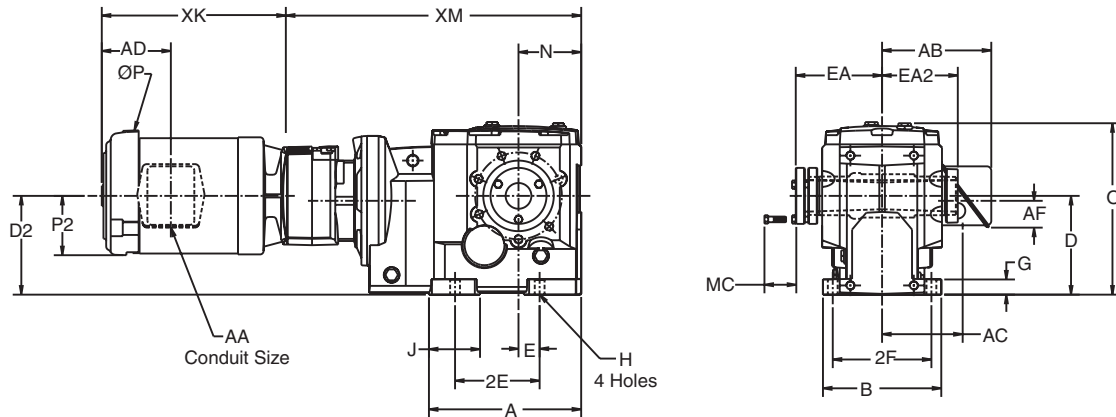

Gear Frame	Version	A	B	D <sup>1</sup>	D2	E	2E	2F	G	H	J	O	N	XM
34	S2	10.13	7.87	7.09	5.57	1.57	5.91	6.50	1.07	.71	2.67	12.05	4.49	21.55
35	S2	11.92	8.66	8.35	6.56	2.17	7.09	7.09	1.18	.87	3.45	13.58	5.20	23.87

### Output Shaft

Gear Frame	Version	EA	EA2	MC <sup>5</sup>	Bushing Bores <sup>4</sup>	
					Min.	Max
34	S2	5.84	5.27	1.88	1 11/16	1 15/16
35	S2	6.17	5.62	1.88	2	2 7/16

Motor Frame	Motor Type <sup>3</sup>	Gear Frame	P	P2	AA	AB	AC	AD	AF	XK
56	T	All	7.31	3.31	.75	6.10	4.50	3.86	1.77	9.79
B56	T	All	7.31	3.31	.75	6.10	4.50	3.86	1.77	11.04
143T, 145T	T	All	7.31	3.31	.75	6.10	4.50	3.86	1.77	11.04
182T/184T	T	35	9.56	4.34	.75	6.10	4.50	5.13	1.77	14.04

<sup>1</sup> Dimension "D" will never be exceeded, but may vary from values shown. When exact dimensions are required, shims up to .03" may be necessary.

<sup>2</sup> All rough casting dimensions may vary by .25" due to casting variations.

<sup>3</sup> Motor dimensions for other than "Type T" three phase TEFC motors, refer to pages B-114 to B-116.

<sup>4</sup> Refer to page B-26 by gear frame for listing of all inch and metric bushing bore sizes available.

<sup>5</sup> The "MC" dimension shows spacing required to install or remove the bushing from the reducer.

<sup>6</sup> Bushing and dust cap can be installed opposite of how they are shown above.

<sup>7</sup> Driven shaft entry can be from either side of the gear reducer housing. Refer to Installation Manual for requirements.

<sup>8</sup> For details of the torque arm kit, refer to page B-22.

## Combined Taper Bushed Shaft Mount OtN36 - 38

Standard conduit box location will be F1 unless specified otherwise.

OtN Series

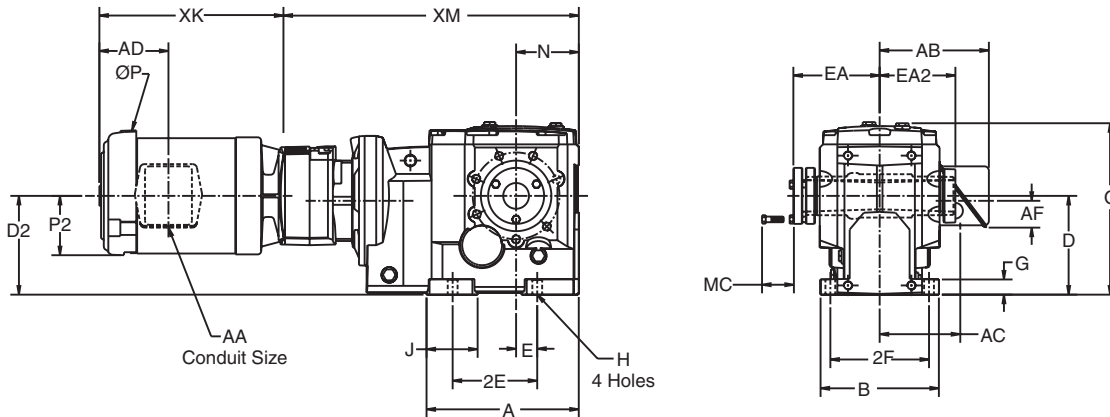

Gear Frame	Version	A	B	D <sup>1</sup>	D <sub>2</sub>	E	2E	2F	G	H	J	O	N	XM
36	S2	17.06	11.41	8.86	8.46	6.99	13.98	9.45	1.57	.87	3.87	16.26	8.74	31.04
37	S2	20.58	12.99	9.84	10.57	8.27	16.54	10.63	1.93	.94	4.78	18.29	10.04	36.37
38	S2	17.85	13.39	14.76	11.48	4.53	13.78	10.63	1.98	1.26	4.06	24.11	8.86	31.94

### Output Shaft

Gear Frame	Version	EA	EA2	MC <sup>5</sup>	Bushing Bores <sup>4</sup>	
					Min.	Max.
36	S2	6.81	7.83	1.88	2 7/16	2 15/16
37	S2	9.50	8.86	2.25	2 7/8	3 7/16
38	S2	8.66	8.08	2.75	2 15/16	3 15/16

Motor Frame	Motor Type <sup>3</sup>	Gear Frame	P	P <sub>2</sub>	AA	AB	AC	AD	AF	XK
56	T	All	7.31	3.31	.75	6.10	4.50	3.86	1.77	9.79
B56	T	All	7.31	3.31	.75	6.10	4.50	3.86	1.77	11.04
143T, 145T	T	All	7.31	3.31	.75	6.10	4.50	3.86	1.77	11.04
182T/184T	T	All	9.56	4.34	.75	6.10	4.50	5.13	1.77	14.04
213T	T	All	11.25	5.06	1.00	8.42	7.17	5.60	2.42	16.15
215T	T	All	11.25	5.06	1.00	8.42	7.17	5.60	2.42	17.65

<sup>1</sup> Dimension "D" will never be exceeded, but may vary from values shown. When exact dimensions are required, shims up to .03" may be necessary.

<sup>2</sup> All rough casting dimensions may vary by .25" due to casting variations.

<sup>3</sup> Motor dimensions for other than "Type T" three phase TEFC motors, refer to pages B-114 to B-116.

<sup>4</sup> Refer to page B-26 by gear frame for listing of all inch and metric bushing bore sizes available.

<sup>5</sup> The "MC" dimension shows spacing required to install or remove the bushing from the reducer.

<sup>6</sup> Bushing and dust cap can be installed opposite of how they are shown above.

<sup>7</sup> Driven shaft entry can be from either side of the gear reducer housing. Refer to Installation Manual for requirements.

<sup>8</sup> For details of the torque arm kit, refer to pages B-22 and B-23.

## 2-Stage CEMA Screw Conveyor Drive OtN32

Standard conduit box location will be F1 unless specified otherwise.

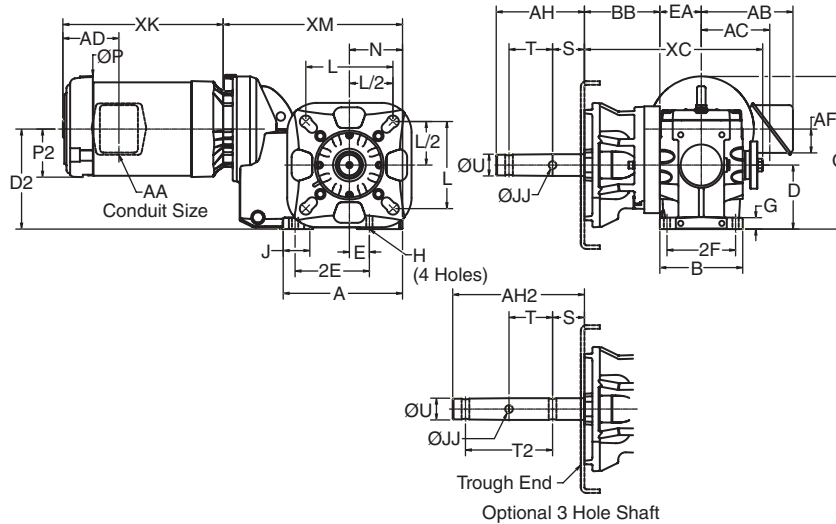

OtN Series

Gear Frame	Version	A	B	D <sup>1</sup>	D2	E	2E	2F	G	H	J	O	N	EA	XC	XM
3242	S2	8.22	5.71	4.41	6.89	1.38	5.12	4.72	.79	.43	1.83	10.51	3.66	2.85	7.35	12.36

### Screw Conveyor

Gear Frame	Screw Dia.	JJ	L	U	S	T	T2	AH	AH2	BB
3242	6-10	.53	4.00	1.50	2.13	3.00	6.00	6.00	9.00	5.13
	9-12	.66	5.13	2.00	2.13	3.00	6.00	6.00	9.00	5.13
	12-14	.66	5.63	2.44	2.75	3.00	6.00	6.00	9.69	5.13
	12-20	.78	6.00	3.00	2.88	3.00	6.00	6.88	9.88	5.13

Motor Frame	Motor Type <sup>4</sup>	Gear Frame	P	P2	AA	AB	AC	AD	AF	XK
56	T	Any	7.31	3.31	.75	6.10	4.50	3.86	1.77	9.79
B56	T	Any	7.31	3.31	.75	6.10	4.50	3.86	1.77	11.04
143T, 145T	T	Any	7.31	3.31	.75	6.10	4.50	3.86	1.77	11.04
182T/184T	T	Any	9.56	4.34	.75	6.10	4.50	5.13	1.77	14.04
213T	T	32	11.25	5.06	1.00	8.42	7.17	5.60	2.42	16.15
215T	T	32	11.25	5.06	1.00	8.42	7.17	5.60	2.42	17.65

<sup>1</sup> Dimension "D" will never be exceeded, but may vary from values shown. When exact dimensions are required, shims up to .03" may be necessary.

<sup>2</sup> All rough casting dimensions may vary by .25" due to casting variations.

<sup>3</sup> Refer to pages B-24 and B-25 for the screw conveyor drive shafts, trough ends and other accessories available for each gear frame size.

<sup>4</sup> Motor dimensions for other than "Type T" three phase TEFC motors, refer to pages B-114 to B-116.

<sup>5</sup> Thrust ratings for each gear frame size are listed on page B-24.

## 3-Stage CEMA Screw Conveyor Drive OtN32 - 33

Standard conduit box location will be F1 unless specified otherwise.

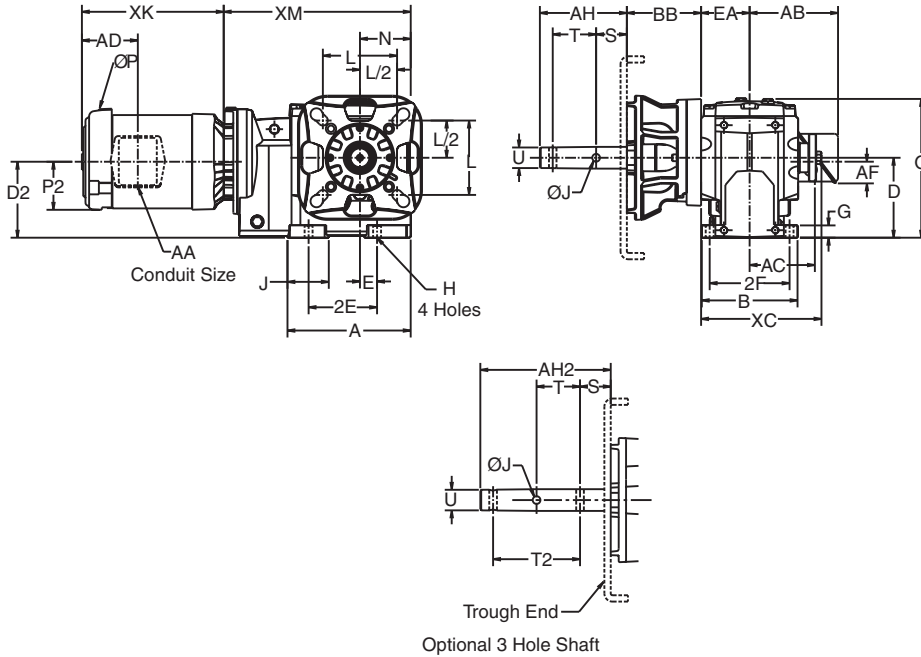

Gear Frame	Version	A	B	D <sup>1</sup>	D2	E	2E	2F	G	H	J	O	N	EA	XC	XM
32	S2	7.81	5.71	4.41	3.78	1.38	5.12	4.71	.73	.43	2.34	8.09	3.03	2.85	7.35	10.98
33	S2	8.50	6.61	5.51	5.24	1.18	4.72	5.51	.85	.55	2.86	9.69	3.54	3.35	8.30	12.90

### Screw Conveyor

Gear Frame	Screw Dia.	J	L	U	S	T	T2	AH	AH2	BB
32, 33	6 - 10	.53	4.00	1.50	2.13	3.00	6.00	6.00	9.00	5.13
	9 - 12	.66	5.13	2.00	2.13	3.00	6.00	6.00	9.00	5.13
	12 - 14	.66	5.63	2.44	2.75	3.00	6.00	6.00	9.69	5.13
	12 - 20	.78	6.00	3.00	2.88	3.00	6.00	6.88	9.88	5.13

Motor Frame	Motor Type <sup>4</sup>	Gear Frame	P	P2	AA	AB	AC	AD	AF	XK
56	T	Any	7.31	3.31	.75	6.10	4.50	3.86	1.77	9.79
B56	T	Any	7.31	3.31	.75	6.10	4.50	3.86	1.77	11.04
143T, 145T	T	Any	7.31	3.31	.75	6.10	4.50	3.86	1.77	11.04
182T/184T	T	Any	9.56	4.34	.75	6.10	4.50	5.13	1.77	14.04
213T	T	33	11.25	5.06	1.00	8.42	7.17	5.60	2.42	16.15
215T	T	33	11.25	5.06	1.00	8.42	7.17	5.60	2.42	17.65

<sup>1</sup> Dimension "D" will never be exceeded, but may vary from values shown. When exact dimensions are required, shims up to .03" may be necessary.

<sup>2</sup> All rough casting dimensions may vary by .25" due to casting variations.

<sup>3</sup> Refer to pages B-24 and B-25 for the screw conveyor drive shafts, trough ends and other accessories available for each gear frame size.

<sup>4</sup> Motor dimensions for other than "Type T" three phase TEFC motors, refer to pages B-114 to B-116.

<sup>5</sup> Thrust ratings for each gear frame size are listed on page B-24.

## 3-Stage CEMA Screw Conveyor Drive OtN34 - 35

Standard conduit box location will be F1 unless specified otherwise.

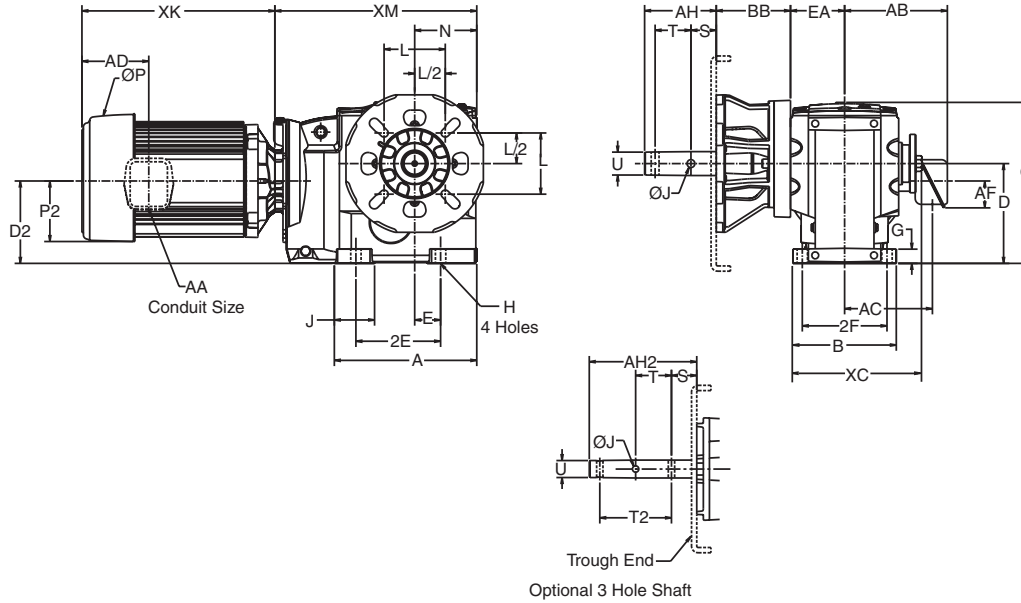

OtN Series

Gear Frame	Version	A	B	D <sup>1</sup>	D2	E	2E	2F	G	H	J	O	N	EA	XC	XM	
																56-215T	254T-286T
34	S2	10.13	7.87	7.09	5.90	1.57	5.91	6.50	1.07	.71	2.67	12.05	4.49	4.07	9.84	14.56	-
35	S2	11.92	8.66	8.35	6.89	2.17	7.09	7.09	1.18	.87	3.45	13.58	5.20	4.43	11.00	16.90	17.25

### Screw Conveyor

Gear Frame	Screw Dia.	J	L	U	S	T	T2	AH	AH2	BB
34	6 - 10	.53	4.00	1.50	2.13	3.00	6.00	6.00	9.00	5.13
	9 - 12	.66	5.13	2.00	2.13	3.00	6.00	6.00	9.00	5.13
	12 - 14	.66	5.63	2.44	2.75	3.00	6.00	6.00	9.69	5.13
	12 - 20	.78	6.00	3.00	2.88	3.00	6.00	6.88	9.88	5.13
35	9 - 12	.66	5.13	2.00	2.13	3.00	6.00	6.00	9.00	6.21
	12 - 14	.66	5.63	2.44	2.75	3.00	6.00	6.69	9.69	6.21
	12 - 20	.78	6.00	3.00	2.88	3.00	6.00	6.88	9.88	6.21
	18 - 24	.91	6.75	3.44	3.88	4.00	-	9.13	-	6.21

Motor Frame	Motor Type <sup>4</sup>	Gear Frame	P	P2	AA	AB	AC	AD	AF	XK
56	T	Any	7.31	3.31	.75	6.10	4.50	3.86	1.77	9.79
B56	T	Any	7.31	3.31	.75	6.10	4.50	3.86	1.77	11.04
143T, 145T	T	Any	7.31	3.31	.75	6.10	4.50	3.86	1.77	11.04
182T/184T	T	Any	9.56	4.34	.75	6.10	4.50	5.13	1.77	14.04
213T	T	Any	11.25	5.06	1.00	8.42	7.17	5.60	2.42	16.15
215T	T	Any	11.25	5.06	1.00	8.42	7.17	5.60	2.42	17.65
254T	T	34	13.38	6.00	1.25	9.79	7.68	8.29	1.81	20.58
	T	35	13.38	6.00	1.25	9.79	7.68	8.29	1.81	19.61
256T	T	34	13.38	6.00	1.25	9.79	7.68	8.29	1.81	22.33
	T	35	13.38	6.00	1.25	9.79	7.68	8.29	1.81	21.36
284T/286T	T	35	14.62	7.29	1.50	11.33	8.51	12.44	2.63	24.26

<sup>1</sup> Dimension "D" will never be exceeded, but may vary from values shown. When exact dimensions are required, shims up to .03" may be necessary.  
<sup>2</sup> All rough casting dimensions may vary by .25" due to casting variations.

<sup>3</sup> Refer to pages B-24 and B-25 for the screw conveyor drive shafts, trough ends and other accessories available for each gear frame size.  
<sup>4</sup> Motor dimensions for other than "Type T" three phase TEFC motors, refer to pages B-114 to B-116.  
<sup>5</sup> Thrust ratings for each gear frame size are listed on page B-24.

## 3-Stage CEMA Screw Conveyor Drive OtN36 - 37

Standard conduit box location will be F1 unless specified otherwise.

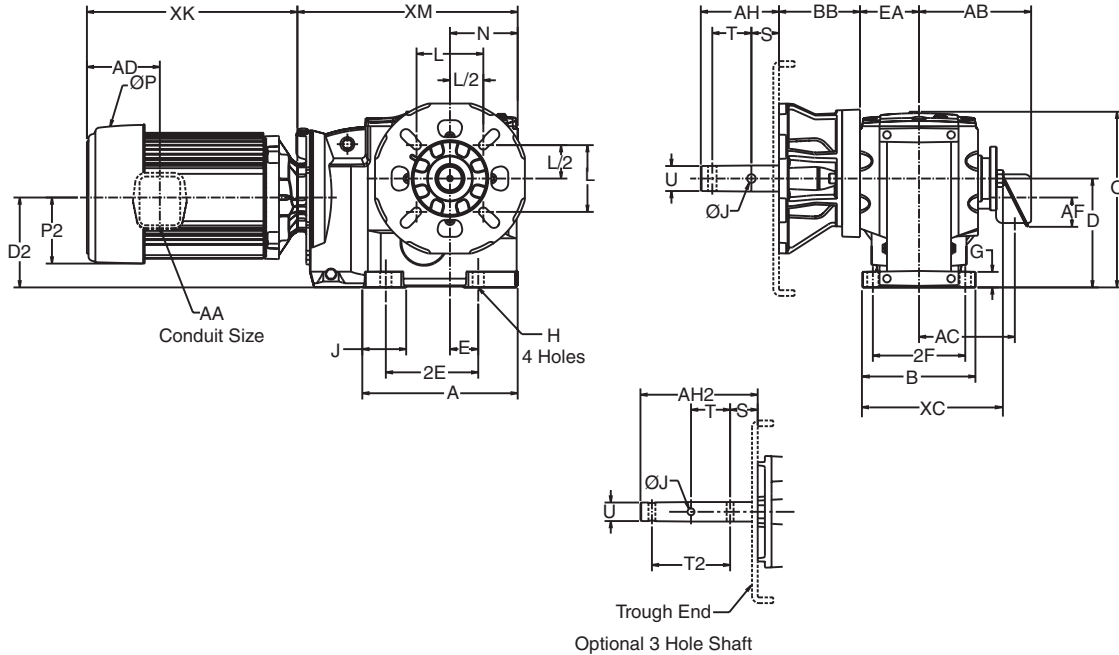

Gear Frame	Version	A	B	D <sup>1</sup>	D2	E	2E	2F	G	H	J	O	N	EA	XC	XM	
																182T/184T	213T-326T
36	S2	17.06	11.41	8.86	8.86	6.99	13.98	9.45	1.57	.87	3.87	16.26	8.74	6.02	13.14	23.38	23.73
37	S2	20.58	12.99	9.84	10.98	8.27	16.54	10.63	1.93	.94	4.78	18.29	10.04	6.61	14.76	-	29.06

### Screw Conveyor

Gear Frame	Screw Dia.	JJ	L	U	S	T	T2	AH	AH2	BB
36	9-12	.66	5.13	2.00	2.13	3.00	6.00	6.00	9.00	6.67
	12, 14	.66	5.63	2.44	2.75	3.00	6.00	6.69	9.69	6.67
	12-20	.78	6.00	3.00	2.88	3.00	6.00	6.88	9.88	6.67
	18-24	.91	6.75	3.44	3.88	4.00	8.00	9.13	13.13	6.67
37	12-20	.78	6.00	3.00	2.88	3.00	6.00	6.88	9.88	7.94
	18-24	.91	6.75	3.44	3.88	4.00	8.00	9.13	13.13	7.94

Motor Frame	Motor Type <sup>4</sup>	Gear Frame	P	P2	AA	AB	AC	AD	AF	XK
182T/184T	T	36	9.56	4.34	.75	6.10	4.50	5.13	1.77	14.04
213T	T	All	11.25	5.06	1.00	8.42	7.17	5.60	2.42	16.15
215T	T	All	11.25	5.06	1.00	8.42	7.17	5.60	2.42	17.65
254T	T	All	13.38	6.00	1.25	9.79	7.68	8.29	1.81	19.61
256T	T	All	13.38	6.00	1.25	9.79	7.68	8.29	1.81	21.36
284T/286T	T	35 - 37	14.62	7.29	1.50	11.33	8.51	12.44	2.63	24.26
324T/326T	T	All	17.2	7.78	2.00	14.99	11.34	14.16	3.63	27.36

<sup>1</sup> Dimension "D" will never be exceeded, but may vary from values shown. When exact dimensions are required, shims up to .03" may be necessary.

<sup>2</sup> All rough casting dimensions may vary by .25" due to casting variations.

<sup>3</sup> Refer to pages B-24 and B-25 for the screw conveyor drive shafts, trough ends and other accessories available for each gear frame size.

<sup>4</sup> Motor dimensions for other than "Type T" three phase TEFC motors, refer to pages B-114 to B-116.

<sup>5</sup> Thrust ratings for each gear frame size are listed on page B-24.



## Combined CEMA Screw Conveyor Drive OtN32 - 33

Standard conduit box location will be F1 unless specified otherwise.

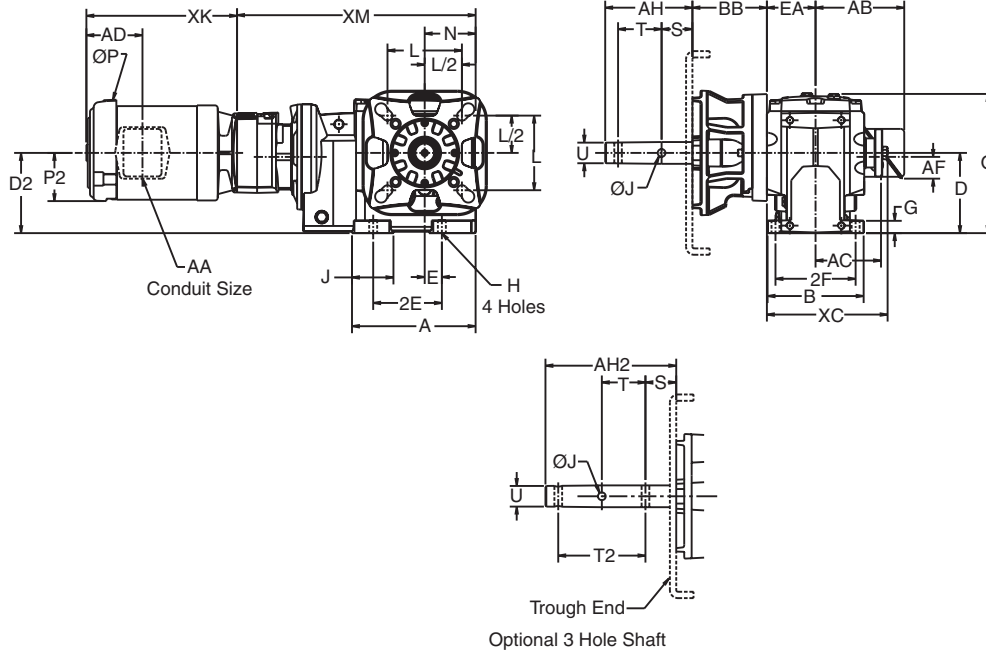

OtN Series

Gear Frame	Version	A	B	D <sup>1</sup>	D <sub>2</sub>	E	2E	2F	G	H	J	O	N	EA	XC	XM
32	S2	7.81	5.71	4.41	4.06	1.38	5.12	4.71	.73	.43	2.34	8.09	3.03	2.85	7.35	14.49
33	S2	8.50	6.61	5.51	4.91	1.18	4.72	5.51	.85	.55	2.86	9.69	3.54	3.35	8.30	19.90

### Screw Conveyor

Gear Frame	Screw Dia.	J	L	U	S	T	T <sub>2</sub>	AH	AH <sub>2</sub>	BB
32, 33	6 - 10	.53	4.00	1.50	2.13	3.00	6.00	6.00	9.00	5.13
	9 - 12	.66	5.13	2.00	2.13	3.00	6.00	6.00	9.00	5.13
	12 - 14	.66	5.63	2.44	2.75	3.00	6.00	6.00	9.69	5.13
	12 - 20	.78	6.00	3.00	2.88	3.00	6.00	6.88	9.88	5.13

Motor Frame	Motor Type <sup>4</sup>	Gear Frame	P	P <sub>2</sub>	AA	AB	AC	AD	AF	XK
56	T	32	7.31	3.31	.75	6.10	4.50	3.86	1.77	10.37
	T	33	7.31	3.31	.75	6.10	4.50	3.86	1.77	9.79
B56	T	32	7.31	3.31	.75	6.10	4.50	3.86	1.77	11.62
	T	33	7.31	3.31	.75	6.10	4.50	3.86	1.77	11.04
143T, 145T	T	33	7.31	3.31	.75	6.10	4.50	3.86	1.77	11.04

<sup>1</sup> Dimension "D" will never be exceeded, but may vary from values shown. When exact dimensions are required, shims up to .03" may be necessary.  
<sup>2</sup> All rough casting dimensions may vary by .25" due to casting variations.  
<sup>3</sup> Refer to pages B-24 and B-25 for the screw conveyor drive shafts, trough ends and other accessories available for each gear frame size.

<sup>4</sup> Motor dimensions for other than "Type T" three phase TEFC motors, refer to pages B-114 to B-116.  
<sup>5</sup> Thrust ratings for each gear frame size are listed on page B-24.

## Combined CEMA Screw Conveyor Drive OtN34 - 35

Standard conduit box location will be F1 unless specified otherwise.

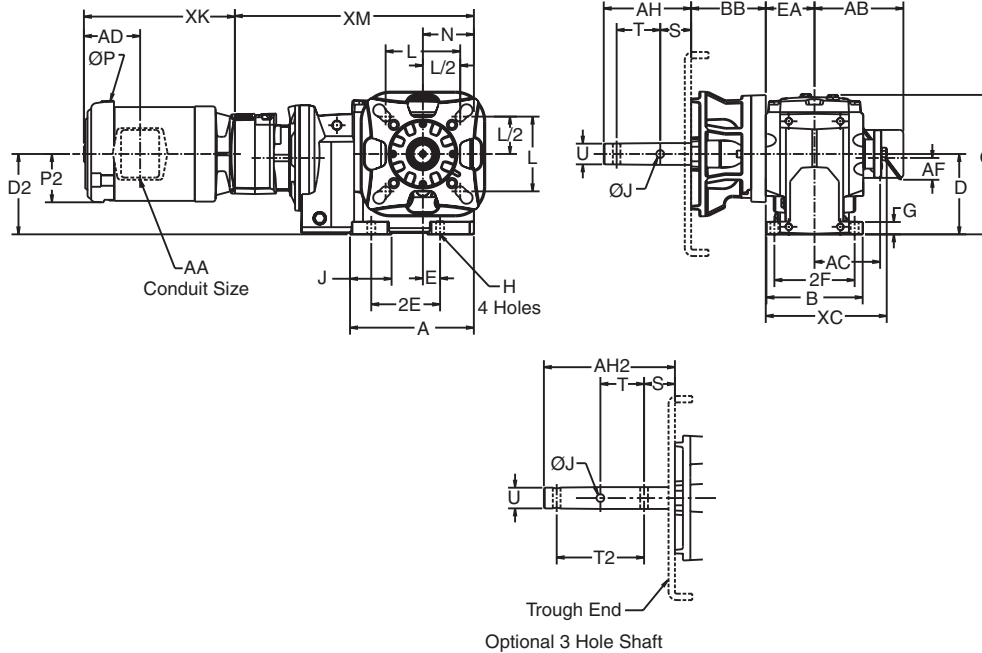

Gear Frame	Version	A	B	D <sup>1</sup>	D <sub>2</sub>	E	2E	2F	G	H	J	O	N	EA	XC	XM
34	S2	10.13	7.87	7.09	5.57	1.57	5.91	6.50	1.07	.71	2.67	12.05	4.49	4.07	9.84	21.55
35	S2	11.92	8.66	8.35	6.56	2.17	7.09	7.09	1.18	.87	3.45	13.58	5.20	4.43	11.00	23.87

### Screw Conveyor

Gear Frame	Screw Dia.	J	L	U	S	T	T <sub>2</sub>	AH	AH <sub>2</sub>	BB
34	6 - 10	.53	4.00	1.50	2.13	3.00	6.00	6.00	9.00	5.13
	9 - 12	.66	5.13	2.00	2.13	3.00	6.00	6.00	9.00	5.13
	12 - 14	.66	5.63	2.44	2.75	3.00	6.00	6.00	9.69	5.13
	12 - 20	.78	6.00	3.00	2.88	3.00	6.00	6.88	9.88	5.13
35	9 - 12	.66	5.13	2.00	2.13	3.00	6.00	6.00	9.00	6.21
	12 - 14	.66	5.63	2.44	2.75	3.00	6.00	6.69	9.69	6.21
	12 - 20	.78	6.00	3.00	2.88	3.00	6.00	6.88	9.88	6.21
	18 - 24	.91	6.75	3.44	3.88	4.00	-	9.13	-	6.21

Motor Frame	Motor Type <sup>4</sup>	Gear Frame	P	P <sub>2</sub>	AA	AB	AC	AD	AF	XK
56	T	Any	7.31	3.31	.75	6.10	4.50	3.86	1.77	9.79
B56	T	Any	7.31	3.31	.75	6.10	4.50	3.86	1.77	11.04
143T, 145T	T	Any	7.31	3.31	.75	6.10	4.50	3.86	1.77	11.04
182T/184T	T	35	9.56	4.34	.75	6.10	4.50	5.13	1.77	14.04

<sup>1</sup> Dimension "D" will never be exceeded, but may vary from values shown. When exact dimensions are required, shims up to .03" may be necessary.

<sup>2</sup> All rough casting dimensions may vary by .25" due to casting variations.

<sup>3</sup> Refer to pages B-24 and B-25 for the screw conveyor drive shafts, trough ends and other accessories available for each gear frame size.

<sup>4</sup> Motor dimensions for other than "Type T" three phase TEFC motors, refer to pages B-114 to B-116.

<sup>5</sup> Thrust ratings for each gear frame size are listed on page B-24.

## Combined CEMA Screw Conveyor Drive OtN36 - 37

Standard conduit box location will be F1 unless specified otherwise.

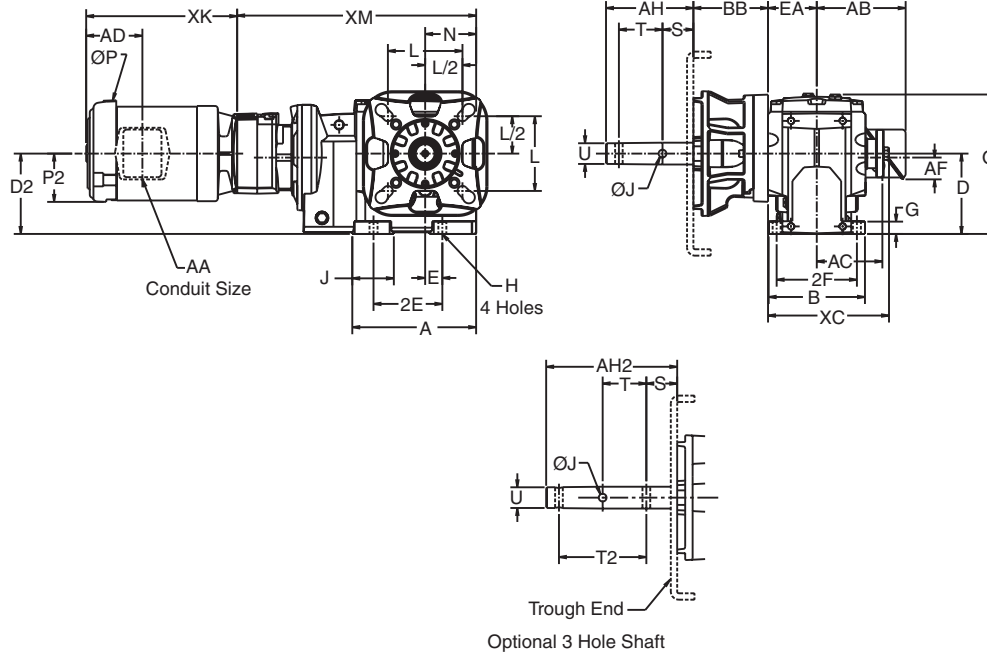

OtN Series

Gear Frame	Version	A	B	D <sup>1</sup>	D2	E	2E	2F	G	H	J	O	N	EA	XC	XM		
																182T/184T	213T-215T	254T-UP
36	S2	17.06	11.41	8.86	8.46	6.99	13.98	9.45	1.57	.87	3.87	16.26	8.74	6.02	13.14	23.38	23.38	23.73
37	S2	20.58	12.99	9.84	10.57	8.27	16.54	10.63	1.93	.94	4.78	18.29	10.04	6.61	14.76	-	29.06	29.41

### Screw Conveyor

Gear Frame	Screw Dia.	JJ	L	U	S	T	T2	AH	AH2	BB
36	9-12	.66	5.13	2.00	2.13	3.00	6.00	6.00	9.00	6.67
	12, 14	.66	5.63	2.44	2.75	3.00	6.00	6.69	9.69	6.67
	12-20	.78	6.00	3.00	2.88	3.00	6.00	6.88	9.88	6.67
	18-24	.91	6.75	3.44	3.88	4.00	8.00	9.13	13.13	6.67
37	12-20	.78	6.00	3.00	2.88	3.00	6.00	6.88	9.88	7.94
	18-24	.91	6.75	3.44	3.88	4.00	8.00	9.13	13.13	7.94

Motor Frame	Motor Type <sup>4</sup>	Gear Frame	P	P2	AA	AB	AC	AD	AF	XK
56	T	All	7.31	3.31	.75	6.10	4.50	3.86	1.77	9.79
B56	T	All	7.31	3.31	.75	6.10	4.50	3.86	1.77	11.04
143T, 145T	T	All	7.31	3.31	.75	6.10	4.50	3.86	1.77	11.04
182T/184T	T	All	9.56	4.34	.75	6.10	4.50	5.13	1.77	14.04
213T	T	All	11.25	5.06	1.00	8.42	7.17	5.60	2.42	16.15
215T	T	All	11.25	5.06	1.00	8.42	7.17	5.60	2.42	17.65

<sup>1</sup> Dimension "D" will never be exceeded, but may vary from values shown. When exact dimensions are required, shims up to .03" may be necessary.

<sup>2</sup> All rough casting dimensions may vary by .25" due to casting variations.

<sup>3</sup> Refer to pages B-24 and B-25 for the screw conveyor drive shafts, trough ends and other accessories available for each gear frame size.

<sup>4</sup> Motor dimensions for other than "Type T" three phase TEFC motors, refer to pages B-114 to B-116.

<sup>5</sup> Thrust ratings for each gear frame size are listed on page B-24.

## 3-Stage Extended Flange Mount OtN34 - 35 (38D)

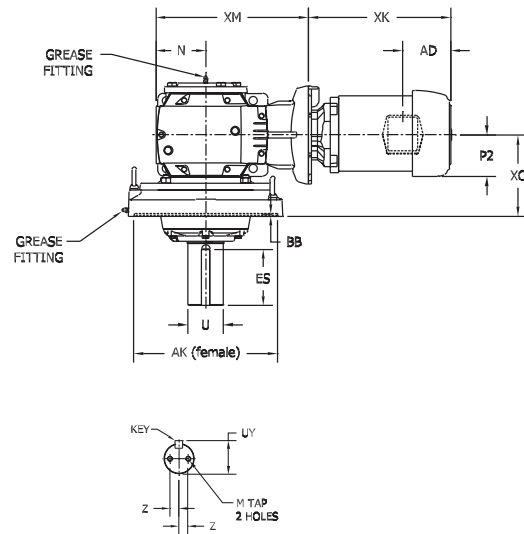
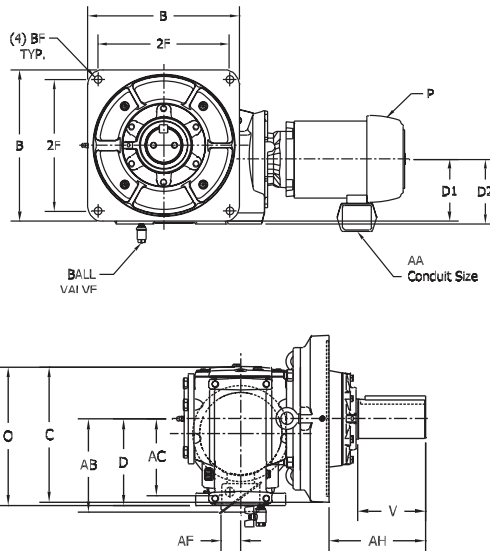

OtN Series

Gear Frame	Version	C	D	D1	O	N	XC	XM	
								56 - 215T	254T-286T
34	S2	12.70	7.09	6.86	11.74	4.49	7.92	14.56	-
35	S2	13.06	8.35	6.59	13.36	5.20	8.51	16.90	17.25

### Output Shaft

Gear Frame	Version	U <sup>1</sup>	UY	V	AH	Key	ES	M	Z
34	S2	3.250	3.574	5.75	8.60	3/4 Sq.	5.00	1/2-13	1.00
35	S2	3.750	4.129	6.50	9.34	7/8 Sq.	5.88	5/8-11	1.13

### Output Flange

Gear Frame	Flange Code	AK	2F	BB	B <sup>2</sup>	BF
34	8	15.000	14.00	0.25	16.09	0.81
35	8	15.000	14.00	0.25	16.09	0.81

Motor Frame	Motor Type <sup>3</sup>	Gear Frame	P	P2	AA	AB	AC	AD	AF	XK
56	T	Any	7.31	3.31	0.75	6.10	4.50	3.86	1.77	9.79
B56	T	Any	7.31	3.31	0.75	6.10	4.50	3.86	1.77	11.04
143T/145T	T	Any	7.31	3.31	0.75	6.10	4.50	3.86	1.77	11.04
182T/184T	T	Any	9.56	4.34	0.75	6.10	4.50	5.13	1.77	14.04
213T	T	Any	11.25	5.06	1.00	8.42	7.17	5.60	2.42	16.15
215T	T	Any	11.25	5.06	1.00	8.42	7.17	5.60	2.42	17.65
254T	T	Any	13.38	6.00	1.25	9.79	7.68	8.29	1.81	19.61 <sup>4</sup>
256T	T	Any	13.38	6.00	1.25	9.79	7.68	8.29	1.81	21.36 <sup>4</sup>
284T/286T	T	35	14.62	7.29	1.50	11.33	8.51	12.44	2.63	24.26

<sup>1</sup> Output shaft extension tolerances +.000", -.001".

<sup>2</sup> Rough casting dimensions may vary up to .25" due to casting variations.

<sup>3</sup> Motor dimensions for other than type "T" three phase TEFC motors, refer to pages B-114 to B-116.

<sup>4</sup> On frame 34, increase the XK by .97"

## 3-Stage Extended Flange Mount OtN36 - 37 (83G)

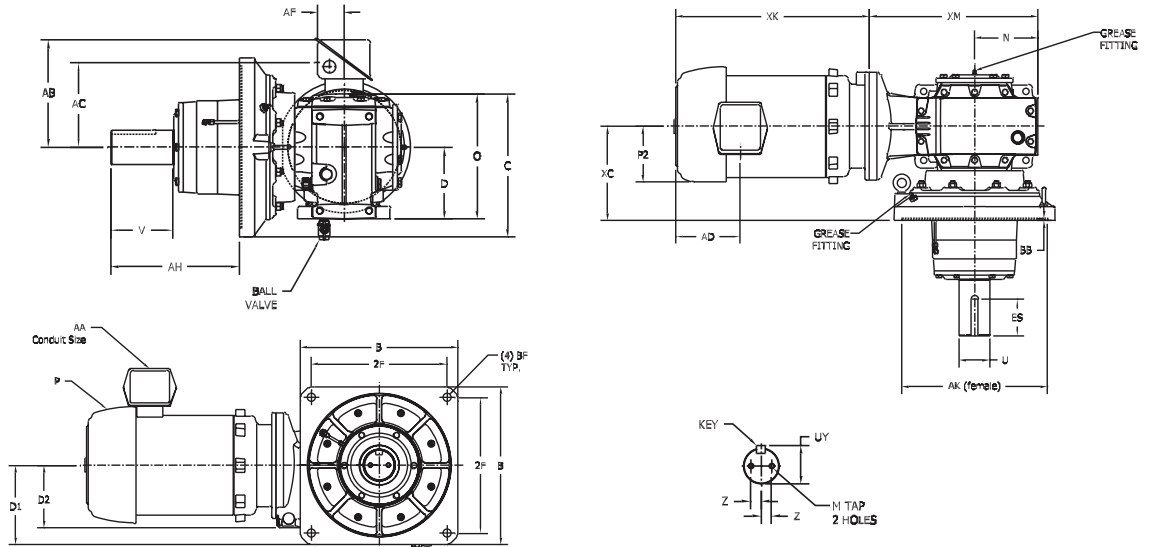

OtN Series

Gear Frame	Version	C	D	D1	O	N	XC	XM	
								56 - 215T	254T-326T
36	S2	17.60	8.86	11.07	15.39	8.74	12.92	23.38	23.73
37	S2	18.49	9.84	12.21	17.27	10.04	13.51	28.71	29.06

### Output Shaft

Gear Frame	Version	U <sup>1</sup>	UY	V	AH	Key	ES	M	Z
36	S2	4.250	4.683	7.50	15.34	1 Sq.	6.50	5/8-11	1.25
37	S2	5.750	6.394	10.00	18.21	1 1/2 Sq.	7.00	3/4-10	1.50

### Output Flange

Gear Frame	Flange Code	AK	2F	BB	B <sup>2</sup>	BF
36	8	20.000	19.00	0.28	22.13	1.13
37	8	20.000	19.00	0.28	22.13	1.13

Motor Frame	Motor Type <sup>3</sup>	Gear Frame	P	P2	AA	AB	AC	AD	AF	XK
143T/145T	T	36	7.31	3.31	0.75	6.10	4.50	3.86	1.77	11.04
182T/184T	T	36	9.56	4.34	0.75	6.10	4.50	5.13	1.77	14.04
213T	T	Any	11.25	5.06	1.00	8.42	7.17	5.60	2.42	16.15
215T	T	Any	11.25	5.06	1.00	8.42	7.17	5.60	2.42	17.65
254T	T	Any	13.38	6.00	1.25	9.79	7.68	8.29	1.81	19.61 <sup>4</sup>
256T	T	Any	13.38	6.00	1.25	9.79	7.68	8.29	1.81	21.36 <sup>4</sup>
284T/286T	T	Any	14.62	7.29	1.50	11.33	8.51	12.44	2.63	24.26
324T/326T	T	Any	17.20	7.78	2.00	14.99	11.34	14.16	3.63	27.36

<sup>1</sup> Output shaft extension tolerances +.000", -.001".

<sup>2</sup> Rough casting dimensions may vary up to .25" due to casting variations.

<sup>3</sup> Motor dimensions for other than type "T" three phase TEFC motors, refer to pages B-114 to B-116.

## Alternate Motor Dimensions

### Single Phase

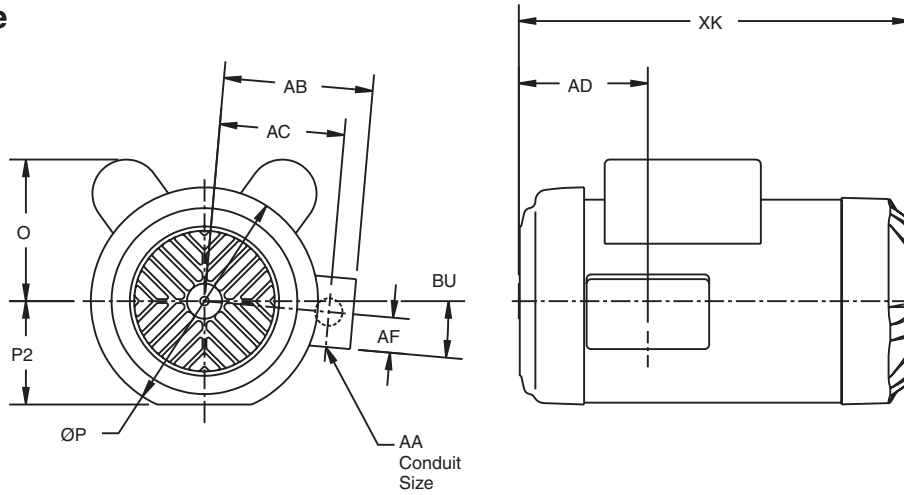

Motor Frame	HP	O	P	P2	AA	AB	AC	AD	AF	BU	XK
56	1/3, 1/2	4.78	7.28	3.31	3/4	4.78	4.00	4.14	1.13	N/A	9.52 <sup>2</sup>
	3/4	4.78	7.28	3.31	3/4	4.78	4.00	4.14	1.13	N/A	11.02 <sup>2</sup>
143T	1	5.09	7.28	3.31	3/4	4.78	4.00	4.14	1.13	N/A	11.02 <sup>2</sup>
145TY	1 1/2, 2	4.53	7.28	3.31	3/4	4.78	3.83	4.14	1.13	5°	12.52
184T	3, 5	5.11	9.56	4.39	3/4	8.58	6.45	7.14	3.09	N/A	16.54

### Corro-Duty®

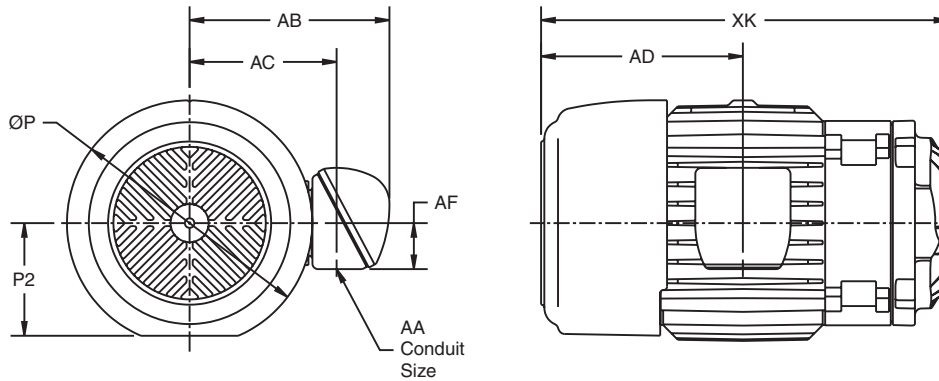

Motor Frame	P	P2	AA	AB	AC	AD	AF	XK
56	7.41	3.44	3/4	6.50	4.59	3.72	1.25	10.21 <sup>2</sup>
143T, 145T	7.41	3.44	3/4	6.50	4.59	3.72	1.25	11.21 <sup>2</sup>
182T, 184T	9.57	4.33	3/4 <sup>3</sup>	7.80	6.00	7.79	2.32	14.23
213T, 215T	11	5.44	1	9.47	7.15	9.63	2.00	19.67
254T, 256T	13.31	6.58	1 1/2	11.33	8.51	12.44	2.63	24.26 <sup>1</sup>
284T, 286T	14.62	7.29	1 1/2	11.33	9.16	13.19	2.63	24.71

<sup>1</sup> XK = 23.29 on OtN 34 three stage and 27A combined.

<sup>2</sup> XK will increase by .58" if used on 32 combined units.

<sup>3</sup> There are 2 conduit openings on this frame size.

**Alternate Motor Dimensions**

**Explosion Proof**

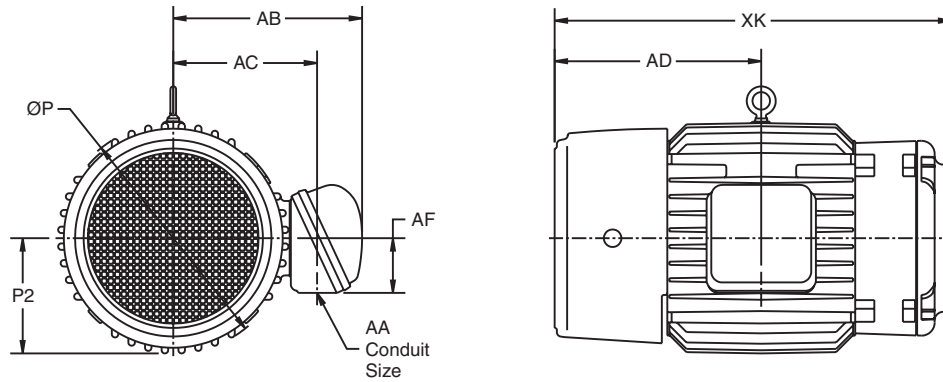

Motor Frame	P	P2	AA	AB	AC	AD	AF	XK
56	7.88	3.38	3/4	6.79	5.31	4.37	1.78	13.15 <sup>2</sup>
143T, 145T	7.88	3.38	3/4	6.79	5.31	4.37	1.78	13.90 <sup>2</sup>
182T, 184T	9.50	4.56	3/4	7.70	5.79	7.75	2.25	15.70
213T, 215T	11.12	5.44	1	9.06	6.81	8.68	2.63	18.72

**IntelliGear®**

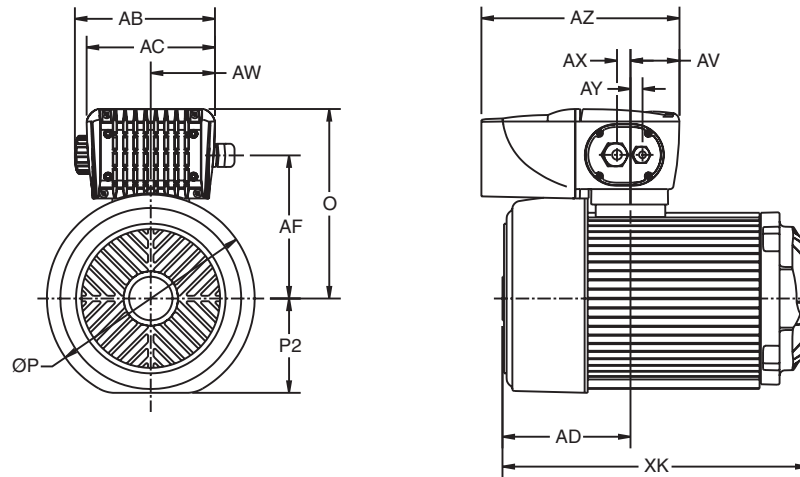

Motor Frame	Controller	O	P	P2	AB	AC	AD	AF	AV	AW	AX	AY	AZ	XK
56	1, 1M	7.74	7.33	3.67	6.45	5.91	4.35	5.61	2.25	2.95	.62	.55	8.53	9.79 <sup>2</sup>
143T, 145T	1	7.74	7.33	3.67	6.45	5.91	4.35	5.61	2.25	2.95	.62	.55	8.53	11.04 <sup>2</sup>
56	2M	7.74	7.33	3.67	6.45	5.91	4.35	5.61	2.25	2.95	.62	.55	9.12	9.79
143T, 145T	2, 2M	7.74	7.33	3.67	6.45	5.91	4.35	5.61	2.25	2.95	.62	.55	9.12	11.04
182T, 184T	2	8.72	9.56	4.78	6.45	5.91	5.89	6.58	2.25	2.95	.62	.55	9.12	14.05
	3	11.16	9.56	4.78	8.97	8.44	10.01	7.37	2.83	4.22	.62	.55	13.10	14.05
213T	3	11.99	11.25	4.98	8.97	8.44	11.73	8.11	2.83	4.22	.62	.55	13.10	16.15
215T	3	11.99	11.25	4.98	8.97	8.44	13.23	8.11	2.83	4.22	.62	.55	13.10	17.65

Input Power Phase/Voltage	Motor HP @ Max. Hz					
	0.33 to 0.50	0.75	1	1.5 to 2	3 to 5	7.5 to 10
1/115	1M	2M	-	-	-	-
1/230	1M	1M	1M	2M	-	-
3/230	1	1	1	2	3	-
3/460	1	1	1	1	2	3

<sup>1</sup> XK = 22.58 on OtN 34 three stage and 27A combined.

<sup>2</sup> XK will increase by .58" if used on 32 combined.

**OtN Series**



Dimensional Supplement

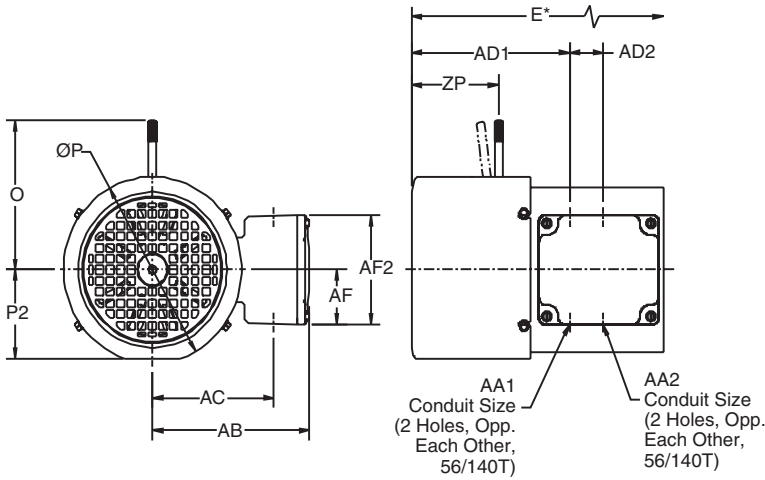

DC FCR Brake with Type "T" Motor

Motor Frame	E*	O	P	AA1	
				Size	Qty
56-143/145T	2.63	5.80	7.24	3/4 NPT	2
182/184T	1.95	7.3	9.23	3/4 NPT	1

Motor Frame	AA2		AB	AC	AD1
	Size	Qty			
56-143/145T	1/2 NPT	2	6.38	4.94	6.43
182/184T	3/4 NPT	1	7.8	6.14	8.84

Motor Frame	AD2	AF	AF2	P2	ZP
56-143/145T	1.38	2.13	4.25	3.46	3.54
182/184T	1.81	2.32	4.65	N/A	4.41

\*Add "E" to XK or C of equivalent three phase frame motor.

Manual Release Lever Position

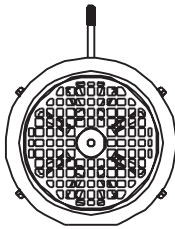

12 o'clock

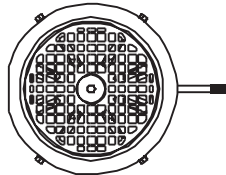

3 o'clock

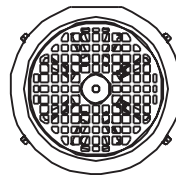

6 o'clock

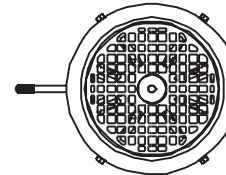

9 o'clock

See page B-18 for specifying the o'clock position on orders.

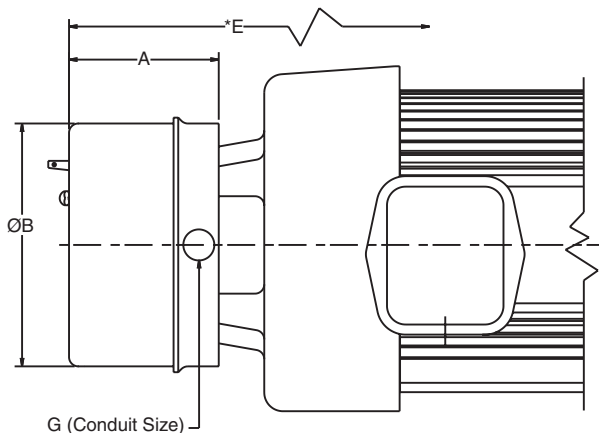

AC Brake with Type "T" and "S" Motor

Motor Frame	Motor Type	Brake Torque (ft. lbs.)	A	B	E*	G
56	S	3	4.01	6.54	4.56	1/2
		6	4.01	6.54	4.56	1/2
143T/145T 145TY		3	4.01	6.54	4.56	1/2
		6	4.01	6.54	4.56	1/2
184T		10	4.01	6.54	4.56	1/2
		15	4.01	6.54	4.56	1/2
213T	T	25	7.38	9.38	8.75	1/2
		35	7.38	9.38	8.75	1/2

\* Dimension "E" represents the additional length of motor with brake mounted. Add this amount to the gearmotor length "C". Add "E" to XK or C of equivalent three phase frame motor.

### TEFC Three Phase Gearmotors

Gear Frame	Reduction Stages	Motor Frame												
		56	143T	145T	182T	184T	213T	215T	254T	256T	284T	286T	324T	326T
31	2	65	74	76	98	101	-	-	-	-	-	-	-	-
32	2	70	79	81	103	106	136	149	-	-	-	-	-	-
	3	77	86	88	110	116	-	-	-	-	-	-	-	-
	5	85	-	-	-	-	-	-	-	-	-	-	-	-
33	3	99	108	110	133	139	167	180	-	-	-	-	-	-
	5.6	129	138	140	-	-	-	-	-	-	-	-	-	-
34	3	147	156	158	181	187	215	228	273	323	-	-	-	-
	5.6	176	185	188	-	-	-	-	-	-	-	-	-	-
35	3	-	231	233	252	258	286	299	344	394	584	604	-	-
	5.6	240	250	253	275	281	-	-	-	-	-	-	-	-
36	3	-	-	-	490	500	539	552	604	654	753	773	845	910
	5.6	509	511	518	533	543	575	583	-	-	-	-	-	-
37	3	-	-	-	726	736	775	788	840	890	949	969	1081	1146
	5.6	745	747	754	769	779	811	819	-	-	-	-	-	-
38	3	-	-	-	-	-	862	875	920	970	1160	1180	1380	1440
	5.6	930	940	943	985	991	993	1000	-	-	-	-	-	-

### Motor Options

Motor Type	Motor Frame														
	56	143T	145T	145TY	182T	184T	213T	215T	254T	256T	284T	286T	324T	326T	
C Corro-Duty	8	9	11	-	52	50	73	70	190	165	0	0	0	0	
X Explosionproof	19	21	25	-	33	30	50	50	-	-	-	-	-	-	
S Single Phase	6	11	-	10	-	17	-	-	-	-	-	-	-	-	
IG Intelligear	7	15	18	-	31	30	51	53	-	-	-	-	-	-	

### Gear Options

Gear Frame	Std Flange Mount	Footed S1	37S or 73S SCD
31	3	-	-
32	4	-	35
33	5	2	35
34	7	3	42
35	8	5	75
36	10	-	109
37	12	-	130
38	15	-	-

\*\* Frames 36 and 37 are only available in S1 design with feet. Refer to upper table for weights on these frames

**Browning**<sup>®</sup>

# OtN Helical-Bevel Right Angle Speed Reducers

OtN Series

**C-Face**

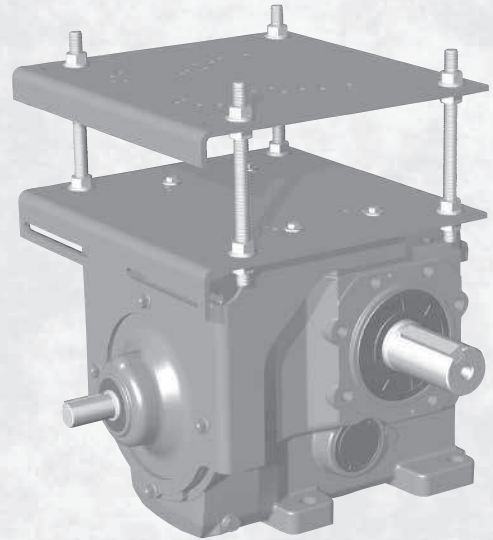
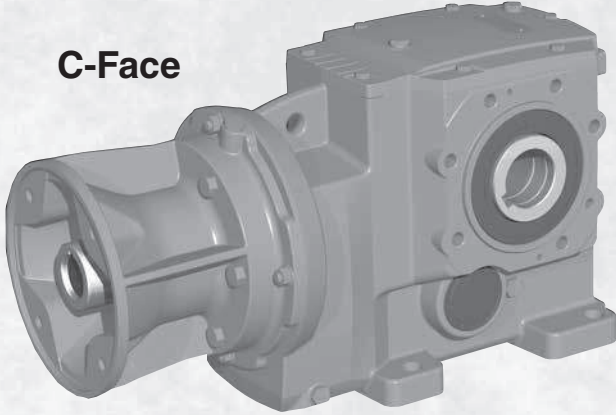

**Top Mount**

**Input Shaft**

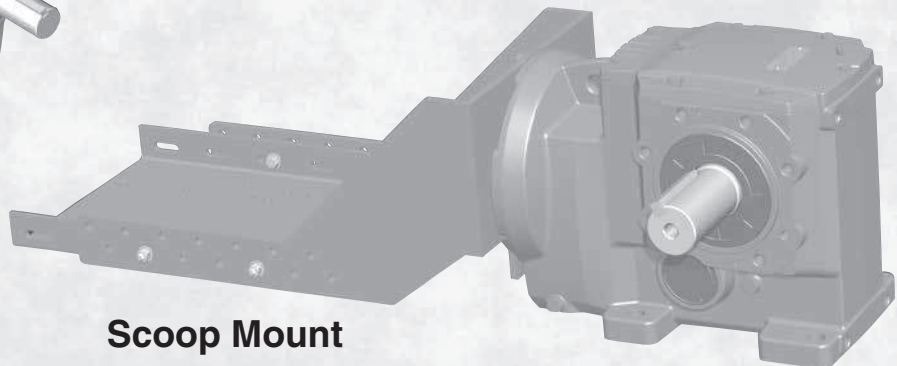
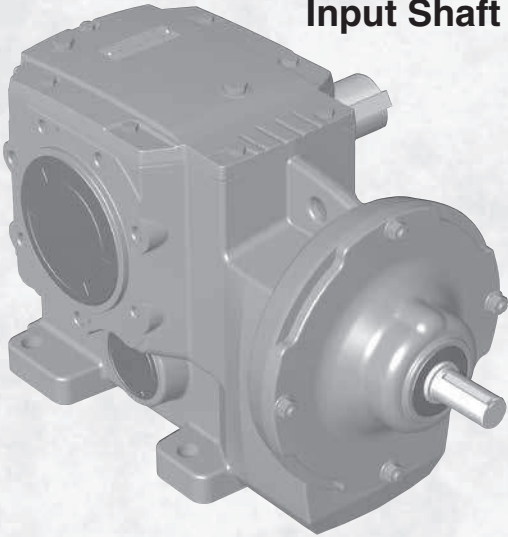

**Scoop Mount**

# Table of Contents

Section	Page
Design Features .....	B-120
Mounting Versatility and Size Range .....	B-121
Speed Reducer Selection.....	B-122 - B-123
Catalog Nomenclature.....	B-124 - B-125
Reducer Mounting Positions.....	B-126
Reducer Input Options.....	B-127
Modifications, Options and Accessories.....	B-128
Torque Reaction Arms.....	B-129 - B-130
Screw Conveyor Accessories.....	B-131 - B-132
Tapered Bushing Selections.....	B-133
AGMA Application Classifications .....	B-134 - B-136
Speed Reducer Selection Tables.....	B-137 - B-142
Thermal Power Ratings .....	B-143 - B-144
Dimension Prints	
C-Face Reducers Output Shafted Foot Mount.....	B-145 - B-149
C-Face Reducers Output Shafted Flange Mount.....	B-150 - B-154
C-Face Reducers Finished Bore Hollow Shaft.....	B-155 - B-159
C-Face Reducers Finished Bore Hollow Shaft Face Mount.....	B-160 - B-164
C-Face Reducers Finished Bore Hollow Shaft Flange Mount.....	B-165 - B-169
C-Face Reducers Taper Bushed Shaft Mount.....	B-170 - B-174
C-Face Screw Conveyor Drive Reducers.....	B-175 - B-179
Input Shaft Reducers Output Shafted Foot Mount.....	B-180 - B-182
Input Shaft Reducers Output Shafted Flange Mount.....	B-183 - B-187
Input Shaft Reducers Finished Bore Hollow Shaft.....	B-188 - B-190
Input Shaft Reducers Finished Bore Hollow Shaft Face Mount.....	B-191 - B-195
Input Shaft Reducers Finished Bore Hollow Shaft Flange Mount.....	B-196 - B-200
Input Shaft Reducers Taper Bushed Shaft Mount.....	B-201 - B-203
Input Shaft Screw Conveyor Drive Reducers.....	B-204 - B-208
Scoop Mount Reducers Output Shafted Foot Mount.....	B-209 - B-211
Scoop Mount Reducers Output Shafted Flange Mount.....	B-212 - B-214
Scoop Mount Reducers Finished Bore Hollow Shaft.....	B-215 - B-217
Scoop Mount Reducers Finished Bore Hollow Shaft Face Mount.....	B-218 - B-220
Scoop Mount Reducers Finished Bore Hollow Shaft Flange Mount.....	B-221 - B-223
Scoop Mount Reducers Taper Bushed Shaft Mount.....	B-224 - B-225
Scoop Mount Screw Conveyor Drive Reducers.....	B-226 - B-227
Top Mount Reducers Output Shafted Foot Mount.....	B-228 - B-230
Top Mount Reducers Finished Bore Hollow Shaft.....	B-231 - B-232
Top Mount Reducers Finished Bore Hollow Shaft Face Mount.....	B-233 - B-234
Top Mount Reducers Taper Bushed Shaft Mount.....	B-236 - B-238
Top Mount Screw Conveyor Drive Reducers.....	B-239 - B-241
Reducer Weights .....	B-242
Lubrication.....	B-243
NEMA Standard Dimensions.....	F-13
General Information.....	F-14
Standard Terms and Conditions of Sale .....	F-15

## Type OtN Helical-Bevel Speed Reducer Features...

OtN Series

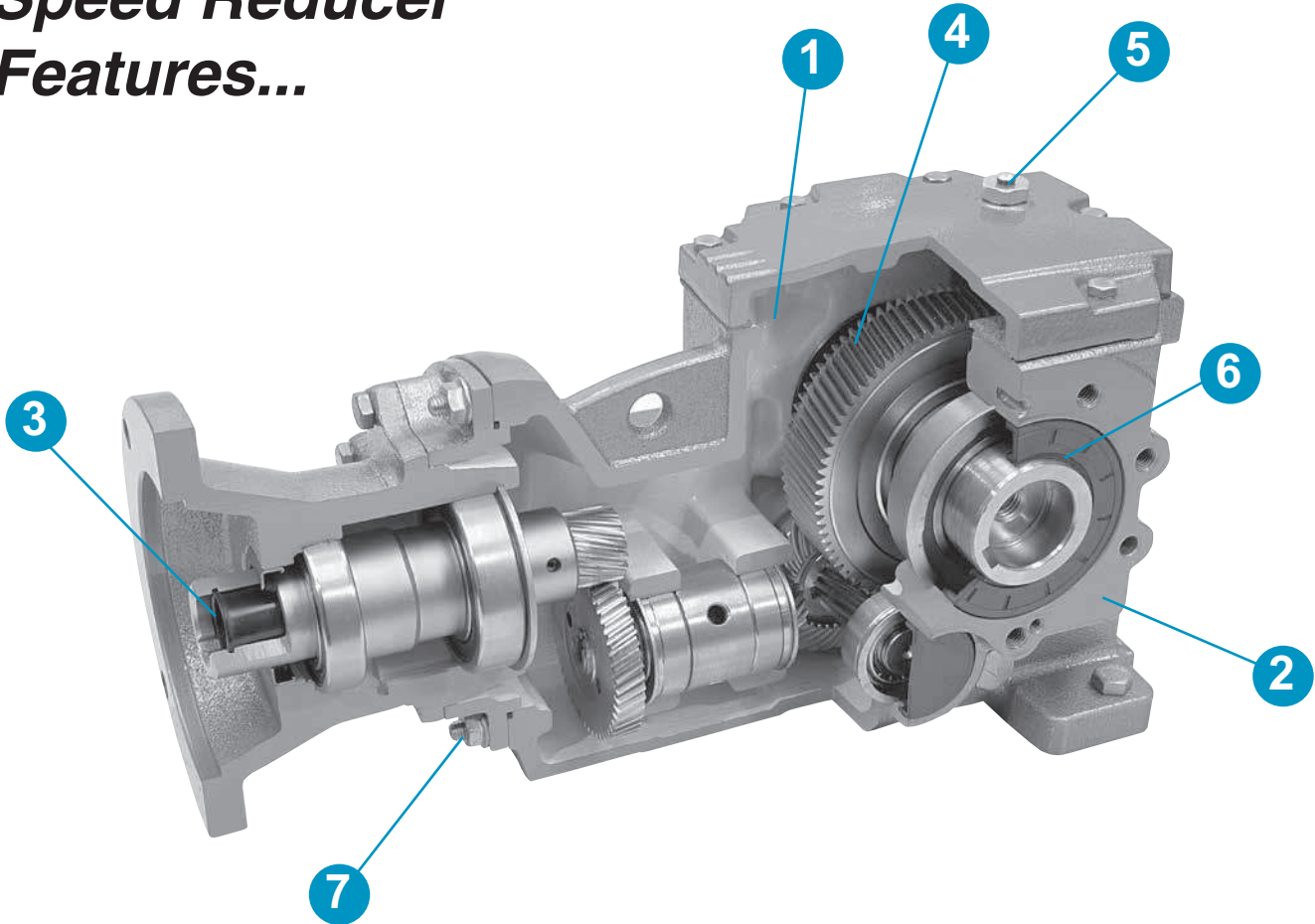

### Design Features

- 1. Gearcase Supplied Factory Filled with Synthetic Oil**
  - Wide temperature range and longer life.
- 2. Corrosion and Shock Resistant Cast Iron Housing**
  - One-piece, reinforced and ribbed for extra strength.
- 3. Series 3000 C-Face Reducers with Compact Quill Design**
  - Non-metallic liner to eliminate fretting.
  - Shorter design.
  - Two bearings for support.
- 4. High Efficiency Helical-Bevel Gears. 98% per Stage**
  - Helical gearing is case hardened and then skived, superfinished or ground.
  - All gears heat shrunk on shafts or mounted on self-locking tapered shafts and keyed for high shock load capability.
- 5. Normally Closed Breather with Multiple Locations (Optional OtN2000)**
- 6. Double Lip Seals on Heat Treated, Plunge Ground Shafts**
- 7. Magnetic Drain Plug Standard**

**Mounting Versatility and Size Range**

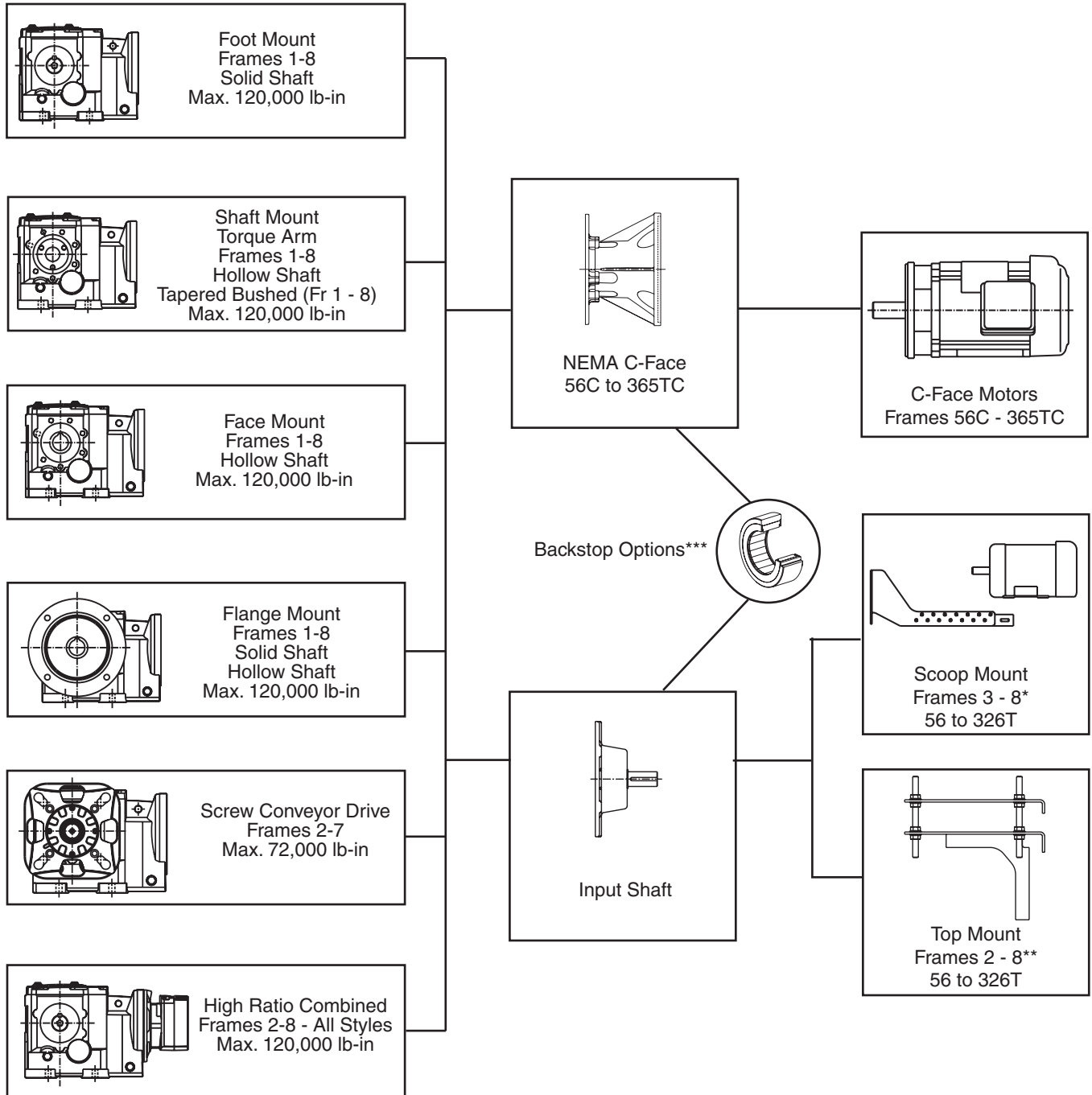

\* Not available for frames 2 - 5, 5-stage or frames 4 - 6, 6-stage.

\*\* Only available for frames 3 - 8, 3-stage, and frame 2 in 2 stage. On frame 8 the Top Mount construction requires production lead-time.

\*\*\*Not available for frames 3245 and 3365A. Available input shaft or scoop mount only for frames 6 - 8.



### Selection Information

1. **Input HP**
  - Based on application data.
2. **Speed/Ratio**
  - Obtain either desired output speed (rpm) or gearbox ratio based on application.
3. **Service Factor**
  - Determine the required service factor using either the AGMA application classification chart (pages B-134 - B-136), or the duration of operation, load type, and drive type with the table below:

Prime Mover	Hours of Operation	Uniform Load U	Moderate Shock Load M	Heavy Shock Load V*
Electric Motor	0 - 3	0.80	1.00	1.50
	3 - 10	1.00	1.25	1.75
	10 - 24	1.25	1.50	2.00
Internal Combustion Engine	0 - 3	1.00	1.25	1.75
	3 - 10	1.25	1.50	2.00
	10 - 24	1.50	1.75	2.25

### Size Selection

#### Step 1

- Locate speed reducer selection tables (pages B-137 - B-142) based on input speed to gearbox.

#### Step 2

- Choose the nominal ratio appropriate for the speeds required.

#### Step 3

- Select the gear unit size for the chosen ratio and the known input speed so that the mechanical power rating P (hp) satisfies the following:

$$P \geq P_m \cdot SF$$

P = mechanical power rating (hp) of gearbox

$P_m$  = motor power (hp)

SF = required service factor

**Note:** Size selection based on absorbed power (Pa) or absorbed torque (Ta) at the low speed shaft instead of motor power (Pm) is allowed when the former is known with sufficient accuracy and if the number of start operations is limited. When Ta is applied in size selection, verify if:

$$T \geq T_a \cdot SF$$

T = torque rating (in. lbs.) at low speed shaft

Ta = absorbed torque (in. lbs.) at low speed shaft

SF = required service factor

\* Applications with reversing or frequent starts and stops should not utilize a C-Face reducer design.

### Size Selection (cont.)

#### Step 4

- Verify overhung load ratings where required (see page B-123).

### Example

#### 1. Application Data

Bottling conveyor, 24-hrs/day operation. Requires right angle hollow shaft mounted speed reducer to be mounted directly to the conveyor drive shaft with a torque arm. The customer prefers a c-face mounted motor.

**Motor rating:** 5 HP, 1750 rpm, 184TC Footless Frame, 230/460 VAC, 3-Phase, 60 Hz, TEFC

**Output speed:** 44 rpm

#### 2. Size Selection

**Nominal Ratio:** Locate nominal rpm closest to 44 rpm. 40:1 nominal ratio is the proper selection.

**Service Factor:** Using AGMA application classification chart (page B-134) under the "Brewing and Distilling" heading, bottling machinery that operates over 10 hours/day should have a 1.25 service factor.

**Rating Req'd:** Minimum reducer rating required is  
 $P = P_m \times SF$   
 $P = 5 \text{ HP} \times 1.25 = 6.25 \text{ HP}$

**Catalog Rating:**

Exact ratio	Gear Frame	39.9	3473
Input H.P.	Output Torque	9.96	13453

**Selection:** OtN3473 is rated 9.96 HP input /13453 lb-in output with 39.9:1 ratio. 1750 rpm / 39.9 = 43.9 rpm output speed. 9.96 / 5 = 1.99 SF.

#### 3. Catalog Designation

**Reducer:** OtN-3473-S2-B33C-40-U-184TC (See page B-123)

**Torque Arm:** ROC400KT001 (See page B-129)



When a sprocket, sheave, pulley, or pinion is mounted on the take-off shaft of a reducer, it is necessary to calculate the overhung load. This calculated load must be compared with the gearbox capacity listed to make sure the gearbox will not be overloaded. To calculate the overhung load you need to know the torque or horsepower at the take-off shaft and the location along the shaft at which the load is applied.

Where:

- OHL = Overhung load (pounds)
- T = Torque (in. lbs.)
- r = Radius of driving member (in.)
- HP = Horsepower
- K = Drive type factor
- LLF = Load location factor

A. If torque is known:

$$OHL = \frac{T \times K \times LLF}{r}$$

B. If horsepower is known:

$$OHL = \frac{63025 \times HP \times K \times LLF}{rpm \times r}$$

Driving Member	Value of K
Chain Drive	1.00
Pinion	1.25
Timing Belt	1.25
V-Belt	1.50
Flat Belt	2.50

Load Location	Value of LLF
End of shaft extension	1.20
Center of shaft extension	1.00
Shaft extension shoulder	0.80

Overhung Load (lbs.)									
Output RPM	Frame								
	Two Stages		Three of More Stages						
	31	32	32	33	34	35	36	37	38
301 - 550	1366	1358	-	-	-	-	-	-	-
175 - 300	1366	1579	-	-	-	-	4497	7097	-
151 - 175	1366	825	825	1392	1653	2565	5126	7834	-
101-150	1366	834	834	1549	1707	2815	5253	8124	9039
51 - 100	1366	902	902	1737	1892	3339	5689	9273	10077
31-50	1366	1148	1148	2090	2435	4100	6595	11017	11537
16-30	1366	1490	1490	2090	2875	4100	8584	12910	12184
5-15	-	-	1490	2090	2875	4100	12209	16982	15622
< 5	-	-	1490	2090	2875	4100	13249	18242	19780

OHL capacities above are calculated at gear capacity rounded to the closest motor HP at mid shaft. For capacity when HP is known, refer to gearmotor selection tables.

## Ordering

OtN • 34 7 3 • S2 • B 33 G • 22.4 • U • 145TC • G11

See pages B-125 and B-126

OtN Series

Browning Right-Angle Helical-Bevel	Series	Reducer Size	Stages	Shaft & Foot Dimensions <sup>1</sup>	Mounting Position	Output Face/Flange Right-Left Viewed From Input End	Output Shaft Configuration Viewed from Input End	Nominal Gear Ratio	Input Type	Motor Frame	Modification(s)	
SERIES 3000		31	3	2= 2 stages	S2 = Industry interchange dimensions	B = Floor mount	3 = Standard round	G = Shaft right	22.4 = 22.4:1	AP = Input Shaft	C-Face 56C-365TC	Select from modifications listed on page B-128
		32	4	3(A) = 3 stages		P = Ceiling mount	4 = Face mount	D = Shaft left	Use nominal ratio selected from reducer selection tables	AD = Input Shaft w/backstop	Scoop Mount 143T-326T	
		33	6	5 = 5 stages	S1 = OtN2000 replacement dimensions	H = Wall mount, input left	5 = Standard dimension flange mount	C = Finish bore		SP = Scoop Mount	Top Mount 56-286T	
		34	7	6 = 6 stages		T = Wall mount, input right	6 = Alternate dimension flange mount	B = Tapered bushed	SD = Scoop Mount w/backstop	See Page B-127		
		35	8			V = Input vertical up	7 = Screw conveyor adapter	S = Screw conveyor shaft	U = C-Face			
		36	9			W = Input vertical down			UD = C-Face w/backstop			
		37	0						TM = Top mount			
		38	2						TMD = Top Mount w/backstop			

<sup>1</sup> Shaft and critical mounting dimensions match either OtN2000 or SEW "K" Series units. These dimensions include the mounting base, output flanges, output shaft diameter, distance from housing center line to shaft tip, and output quill diameter. B14 mounting faces and overall product envelope (height, width, depth) do NOT match.

SEW is believed to be a trade name of SEW-Eurodrive GMBH & Co. and is NOT owned or controlled by Emerson. Emerson cannot and does not represent or warrant the accuracy of this information.

### Output Flange Sizes

Flange Dimensions (mm)											
<b>BD</b>	140	165	200	250	300	350	400	450	550	660	
<b>AK</b>	95	110	130	180	230	250	300	350	450	550	
<b>AJ</b>	115	130	165	215	265	300	350	400	500	600	
<b>Gear Frame</b>	<b>Output Flange Type Designation Code</b>										
<b>31</b>	6	5									
<b>32</b>			5	6							
<b>33</b>				5	6						
<b>34</b>					5	6					
<b>35</b>						5	6				
<b>36</b>								5	6		
<b>37</b>								5	6		
<b>38</b>									5	6	

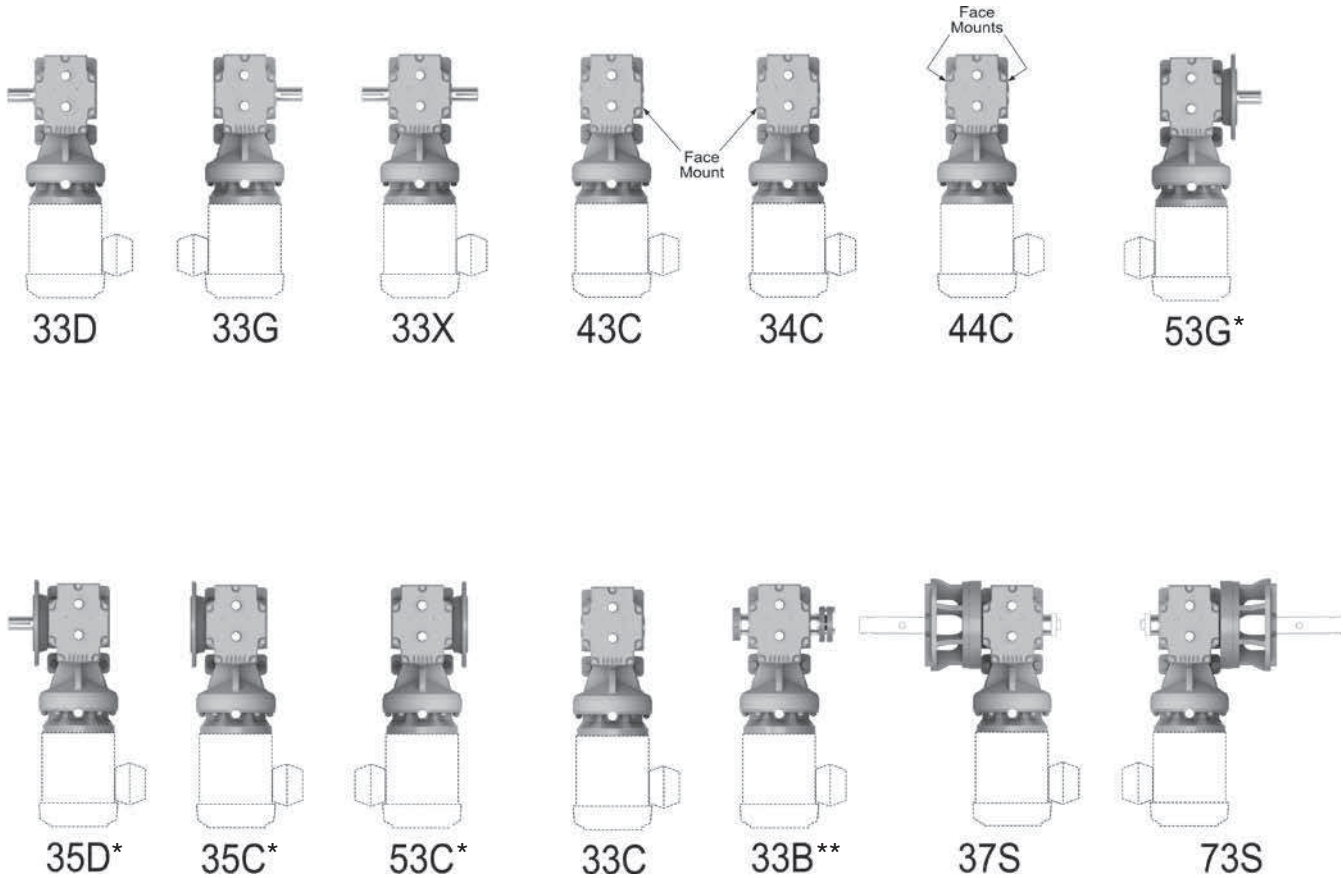

**Examples Above are Top Views (with C-Face motor)**

OtN Frame	Foot Mounted			Face Mounted				Flange Mounted					Shaft Mounted		Screw Conveyor Drive	
	Solid Shaft			Hollow Shaft				Solid Shaft		Hollow Shaft			Hollow	Bushed	73S	37S
	33G	33D	33X	33C	34C	43C	44C	53G	35D	53C	35C	55C	33C	33B**		
31	●	●	●	●	●	●	●	●	●	●	●	●	●	●	-	-
32	●	●	●	●	●	●	●	●	●	●	●	●	●	●	●	●
33	●	●	●	●	●	●	●	●	●	●	●	●	●	●	1	●
33A	-	-	-	-	-	-	-	-	-	-	-	-	-	●	-	-
34	●	●	●	●	●	●	●	●	●	●	●	●	●	●	●	●
35	●	●	●	●	●	●	●	●	●	●	●	●	●	●	●	●
36	●	●	●	●	●	●	●	●	●	●	●	●	●	●	●	●
37	●	●	●	●	●	●	●	●	●	●	●	●	●	●	●	●
38	●	●	●	●	●	●	●	●	●	●	●	●	●	●	-	-

If shaded, the alternative flange can be specified by replacing "5" with "6" in the coding

● This is available at normal lead-time

\* See note for shaded field for flange option

\*\* Bushing can be assembled on either side of reducer during field mounting

1 Frame 33 bushed design will be using the 33A frame and 115 SMTP bushing system

**Foot Mount**

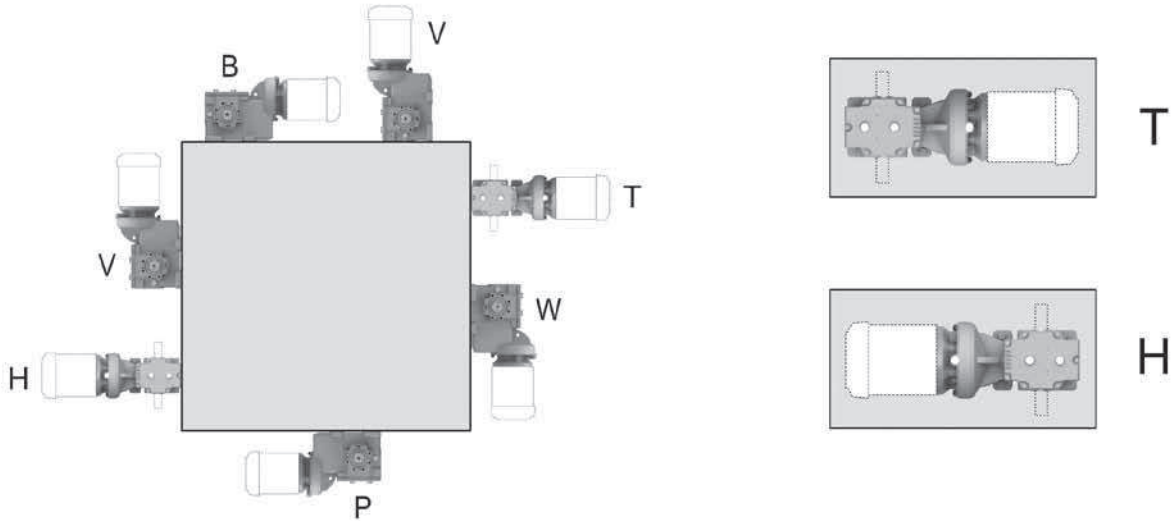

**Foot Mount with Face or Flange**

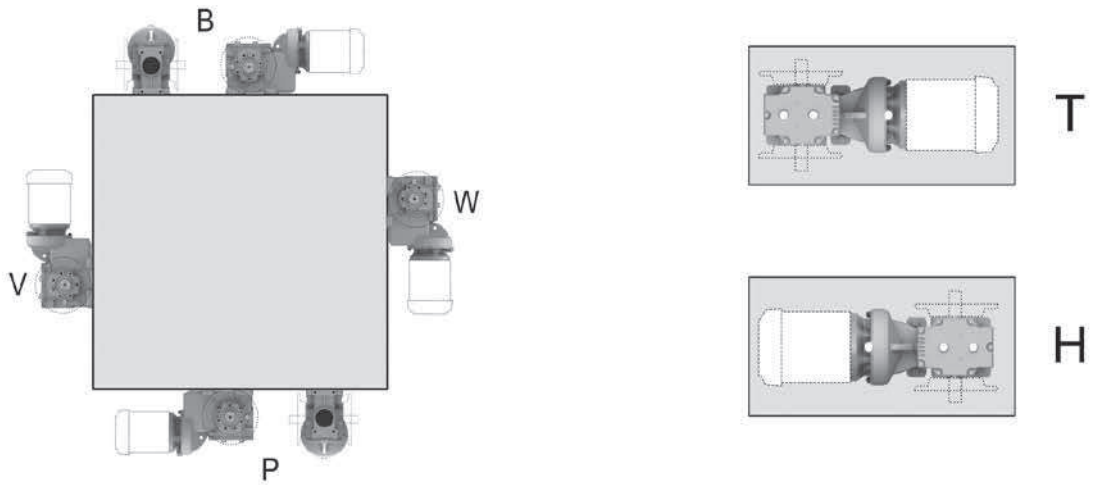

**Flange, Face or Shaft Mount**

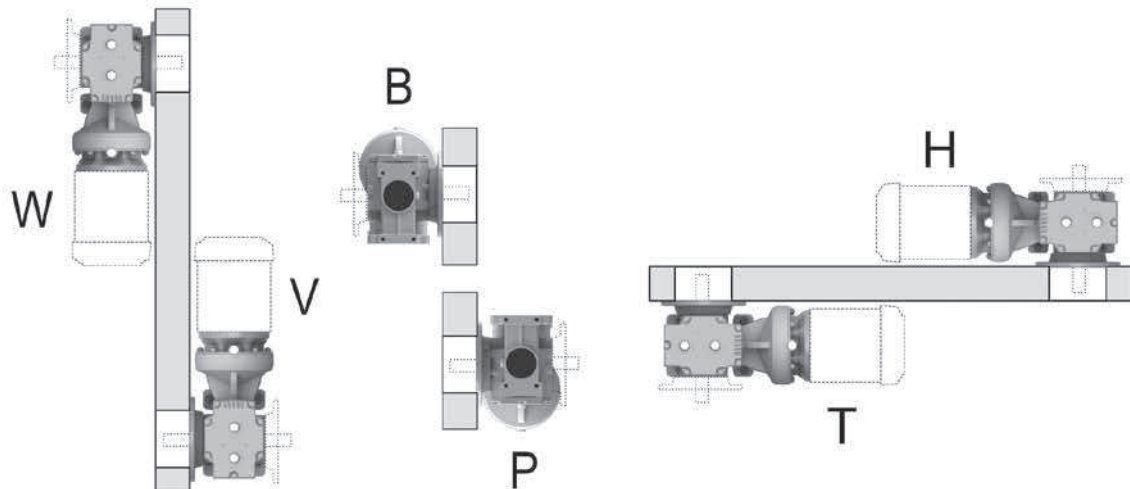

C-Face Frames								
Gear Frame	AC Motor Frame Sizes							
	56C	140TC	180TC	210TC	250TC	280TC	320TC	360TC
3132	X	X						
3242	X	X	X					
3243	X	X	X					
3245	X	X						
3363 (A)	X	X	X	X				
3365	X	X	X					
3473	X	X	X	X				
3475/3476	X	X	X					
3583	X	X	X	X	X	X		
3585/3586	X	X	X					
3693			X	X	X	X	X	
3695/3696	X	X	X	X				
3703			X	X	X	X	X	X
3705/3706	X	X	X	X				
3823				X	X	X	X	X
3825/3826	X	X	X	X				

Scoop Mount Frames								
Gear Frame <sup>1</sup>	AC Motor Frame Sizes							
	56	140T	180T	210T	250T	280T	320T	
3363 (A)	X	X						
3473	X	X	X					
3583		X	X	X				
3693		X	X	X	X	X		
3695/3696	X	X						
3703		X	X	X	X	X	X	X
3705/3706		X	X					
3823			X	X	X	X	X	X
3825/3826		X	X					

Top Mount Frames								
Gear Frame <sup>1</sup>	AC Motor Frame Sizes							
	56	140T	180T	210T	250T	280T	320T	
3242	X	X						
3363 (A)	X	X	X					
3473	X	X	X	X				
3583		X	X	X	X			
3693		X	X	X	X	X	X	X
3703			X	X	X	X	X	X
3823			X	X	X	X	X	X

<sup>1</sup> Frames not listed on the above tables are not offered in this configuration  
 X Available in this input design for frame of motor noted.

## Modifications, Options and Accessories

### Gear Modifications

#### G11 Corro-Duty® Reducer

Corro-Duty treatment can be applied to a reducer when the unit will be subjected to harsh chemicals or used outside. Special features of this treatment include:

- Normally closed breather design
- Corro-Duty exterior paint treatment (entire unit)
  - o Grey Option (default type)
    - 316 stainless steel paint (3 step)
    - Light grey semigloss finish
    - USDA and FDA approved
  - o White Option
    - Two step epoxy paint system
    - White gloss finish
    - USDA and FDA approved

For washdown application, refer to G12b Washdown FG Service Reducer modification.

#### G12a Foodgrade Synthetic Lubricant

When this modification is specified, the OtN oil sump is filled with the required volume of an FDA approved H1 rated synthetic lubricant for helical gearing (refer to page B-245).

#### G12b Washdown FG Service Reducer

When this modification is specified, a reducer will be built with all the features detailed above under G11 and G12a. When ordering, state the paint finish that is to be provided.

#### G15 Export Boxing

Export boxing can be provided for “under-deck” transport. When the quantity of OtN gearmotors or reducers exceeds five (5) units, refer to international sales for most economical accommodations.

#### G16 Extra or Special Nameplate

Units can be provided with limited additional special information on the standard product nameplate. When required, an extra nameplate may be provided, stamped with custom markings.

### Accessories

The following accessories can be ordered along with reducers and will be supplied loose for mounting by others:

Description	Gear Frames	Part #
NPT Adapter (1/4" NPFT)	31 to 35	0436216
NPT Adapter (3/4" NPFT)	36 to 38	0436218
Bushing Guard Kit <sup>1</sup> (includes 2 guards to protect both sides)	31	XS9154
	32	XS9134
	33	XS9135
	33A	XS9768
	34	XS9136
	35	XS9137
	36	XS9158
	37	XS9159
Oil Level View Port	38	PLA335F0002*
	31 to 35	0435936
Coupling Guard Kit (scoop mount reducers)	36 to 38	0435938
	33 to 35	0965634
	36 to 38 up to 250T	0965635
	36 to 38 280-320T	0965636
	36 to 38 combined	0965634

<sup>1</sup> These kits include all mounting hardware.

\* These kit contains only (1) Guard.

**Torque Reaction Arm**

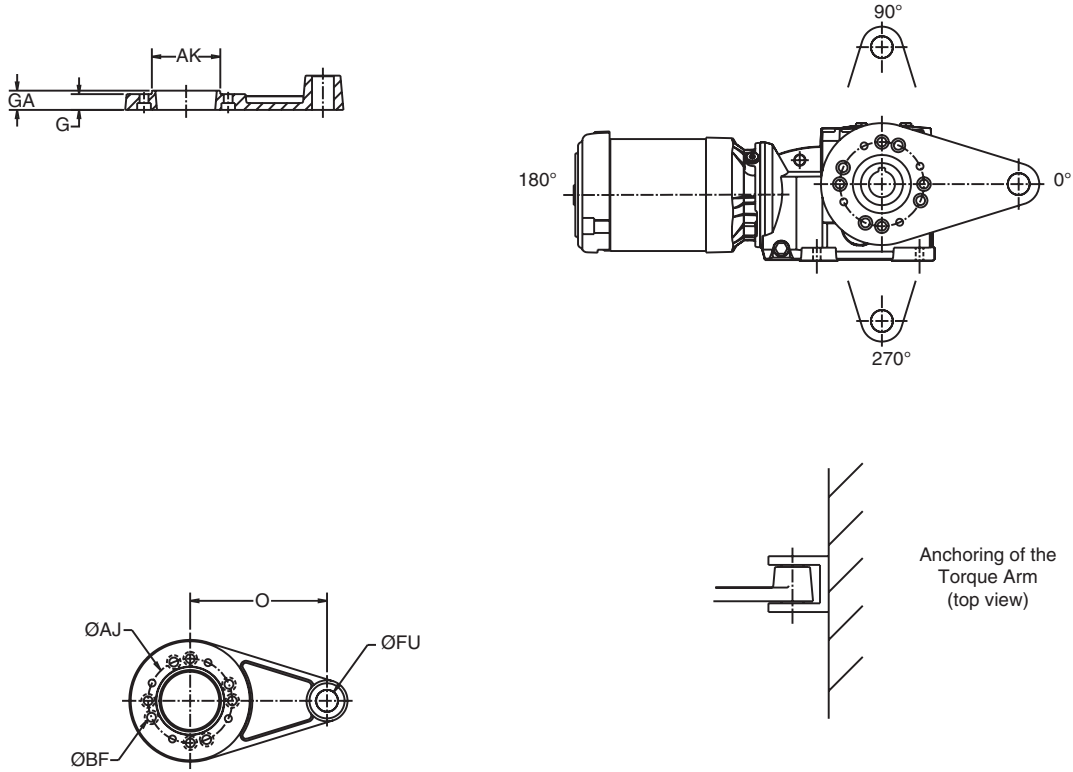

- Torque arm can be assembled in any of the three positions shown in the drawing above relative to the input (motor) when called out on the order.
- Torque arm can be affixed to either side of the 33C or 33B gear housing.
- If torque arm is requested on an assembly order, it will be supplied loose for mounting by others.
- See page 130 for optional torque arm design for frames 36 and 37.

**Series 3000**

OtN Frame	Part ID # Kit	G	O	AJ	AK	BF	FU	GA
31	ROC100KT001	-	5.118	3.74	3.246	.35	.394	.63
32	ROC200KT001	.63	5.118	3.94	3.150	.43	.394	.79
33	ROC300KT001	.91	7.874	4.84	3.937	.51	.630	1.10
34	ROC400KT001	-	9.842	5.98	5.118	.51	.630	.91
35	ROC500KT001	-	12.205	7.48	6.102	.67	.630	.908
36	ROC600KT001	0.79	13.78	9.06	5.905	.63	.940	.98
37	ROC700KT001	1.02	17.72	9.06	7.087	.87	.940	1.22
38	ROC800KT001	1.10	21.65	11.81	9.84	.87	2.20	1.34



**Torque Reaction Arm**

OtN Series

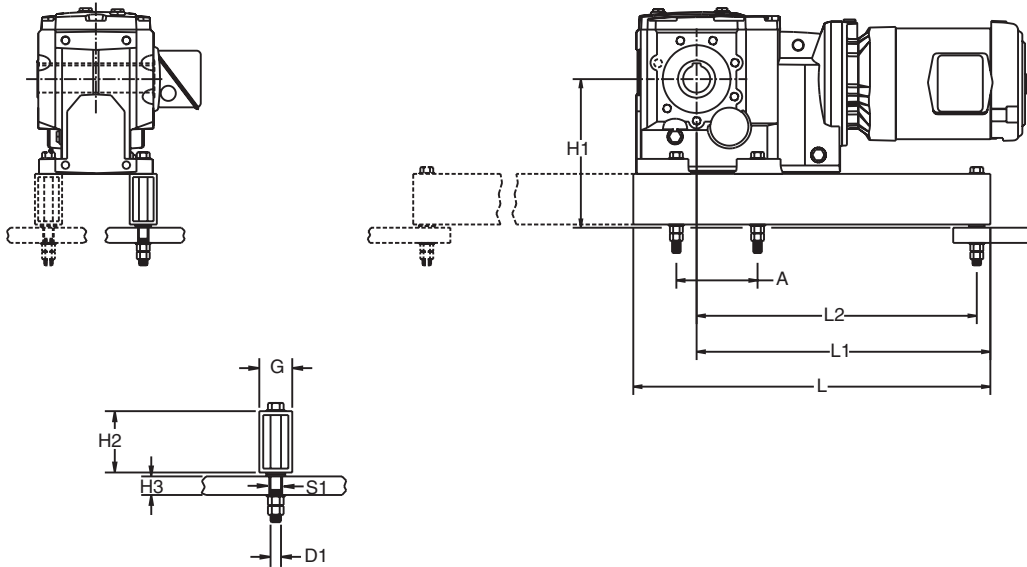

- Torque arm can be assembled with attachment point on the input side or 180° opposite this, as shown above.
- Torque arm can be attached onto feet on either side of the gear housing as you face opposite the input (motor).
- If a torque arm is requested on a assembly order, it will be supplied loose for mounting by others.

Gear Frame	Part Number	A	D1	G	H1	H2	H3 max.	L	L1	L2	S1 min.
36	0986479	13.98	.75	2.50	13.61	4.50	1.50	35.83	27.46	26.08	0.81
37	0986479	16.54	.75	2.50	14.59	4.50	1.50	35.83	26.18	24.80	0.81

## Screw Conveyor Drive Shafts<sup>2</sup>

Gear Frame	1 1/2" Dia. Shaft for 6" - 10" Dia. Screw	2" Dia. Shaft for 9" - 12" Dia. Screw	2 7/16" Dia. Shaft for 12" - 14" Dia. Screw	3" Dia. Shaft for 12" - 20" Dia. Screw	3 7/16" Dia. Shaft for 18" - 24" Dia. Screw
32	107DSP108__	107DSP200__	107DSP207__	107DSP300__	N/A
33	107DSP108__	107DSP200__	107DSP207__	107DSP300__	N/A
34	115DSP108__	115DSP200__	115DSP207__	115DSP300__	N/A
35	N/A	207DSP200__	207DSP207__	207DSP300__	207DSP307__
36	N/A	215DSP200__	215DSP207__	215DSP300__	215DSP307__
37	N/A	N/A	N/A	307DSP300__	307DSP307__

<sup>2</sup> Complete the shaft part number by adding shaft type as follows:

- Standard — 2 hole steel shaft = leave blank (example 107DSP108)
- Optional — 3 hole steel shaft = add -3 (example 107DSP108-3)
- Optional — 2 hole stainless steel shaft = add SS (example 107DSP108SS)
- Optional — 3 hole stainless steel shaft = add -3SS (example 107DSP108-3SS)

## Screw Conveyor Accessories

Gear Frame	Optional Seal Cartridges		Felt Seal <sup>1</sup>
	Waste Pack Kit	Packing Gland Kit	
32	107WWP	107PGP	FR200
33	107WWP	107PGP	FR200
34	115-203WWP	115-203PGP	FR210
35	207-407WWP	207-407PGP	FR308
36	207-407WWP	207-407PGP	FR308
37	207-407WWP	207-407PGP	FR308

<sup>1</sup> Felt seal can only be added to the waste pack seal cartridge kit.

### OtN Screw Conveyor Drives May Be Assembled in the Field

Required Components Include: OtN 73S or 37S gearmotor with screw conveyor adapter  
Screw conveyor drive shaft

Optional Components Include: Waste pack  
Packing gland  
Felt seal

Screw Conveyor Adapter  
(Included with type 73S or 37S gear unit)

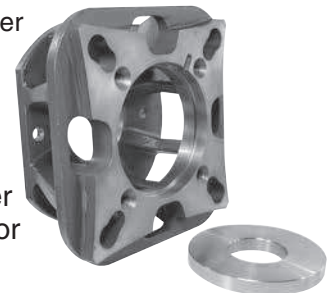

Waste Pack Kit



Packing Gland Kit



Screw Conveyor Drive Shaft Kit

## Screw Conveyor Thrust Ratings

Gear Frame	Maximum Thrust Rating (Lbs.)
32	2000
33	3000
34	4000
35	5000
36	6500
37	11000

Output tapered roller bearing standard - all sizes.

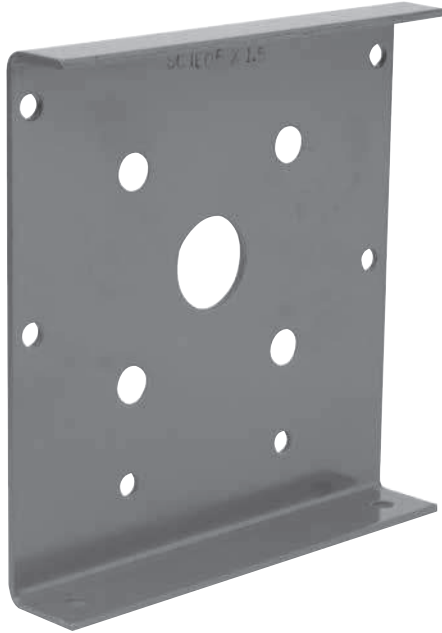

Formed Hot Roll Plate Steel

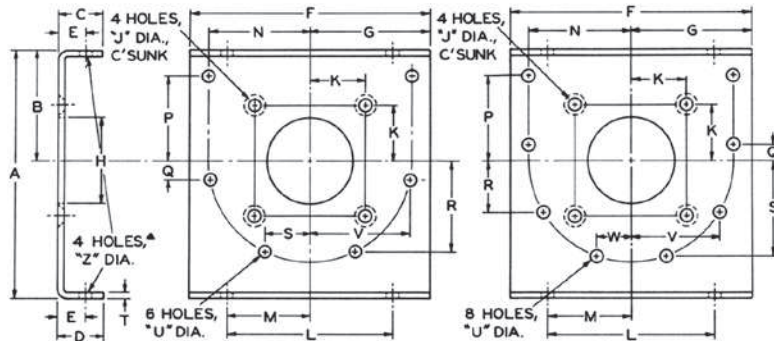

FIG 1 - 6 HOLE TYPE

FIG 2 - 8 HOLE TYPE

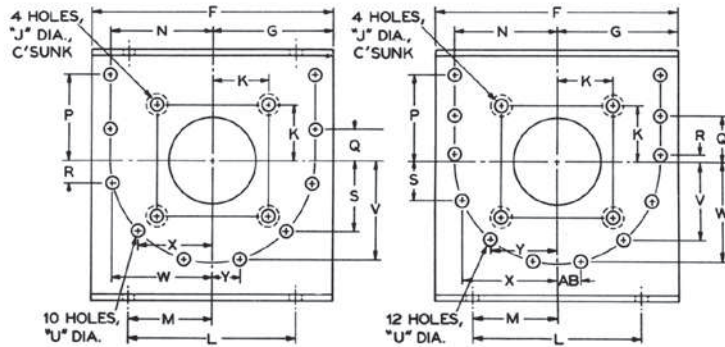

FIG 3 - 10 HOLE TYPE

FIG 4 - 12 HOLE TYPE

Table No. 33

Specifications

Part No.	Conveyor Screw Dia.	Drive Shaft Dia.	Fig.	Type	Dimensions										
					A	B	C	D	E	F	G	H	J	K	L
SCTE06 x 1 1/2"	6"	1 1/2"	1	6-Hole	10 1/8"	4 1/2"	1 1/2"	1 3/4"	1"	9 3/4"	4 7/8"	1 3/4"	9/16"	2"	8 1/8"
SCTE09 x 1 1/2"	9	1 1/2	2	8-Hole	14	6 1/8	1 5/8	2 5/8	1 1/2	13 3/4	6 7/8	1 3/4	9/16	2	9 3/8
SCTE09 x 2	9	2	2	8-Hole	14	6 1/8	1 5/8	2 5/8	1 1/2	13 3/4	6 7/8	2 1/4	11/16	2 9/16	9 3/8
SCTE10 x 1 1/2"	10	1 1/2	2	8-Hole	15 1/4	6 3/8	2 3/8	2 7/8	1 3/4	14 3/4	7 3/8	1 3/4	9/16	2	9 1/2
SCTE10 x 2	10	2	2	8-Hole	15 1/4	6 3/8	2 7/8	2 7/8	1 3/4	14 3/4	7 3/8	2 1/4	11/16	2 9/16	9 1/2
SCTE12 x 2	12	2	2	8-Hole	17 3/8	7 3/4	2	2 3/4	1 5/8	17 1/4	8 5/8	2 1/4	11/16	2 9/16	12 1/4
SCTE12 x 2 7/16	12	2 7/16	2	8-Hole	17 3/8	7 3/4	2	2 3/4	1 5/8	17 1/4	8 5/8	2 11/16	11/16	2 13/16	12 1/4
SCTE12 x 3	12	3	2	8-Hole	17 3/8	7 3/4	2	2 3/4	1 5/8	17 1/4	8 5/8	3 1/4	13/16	3	12 1/4
SCTE14 x 2 7/16	14	2 7/16	2	8-Hole	20 1/8	9 1/4	2	2 7/8	1 5/8	19 1/4	9 5/8	2 11/16	11/16	2 13/16	13 1/2
SCTE14 x 3	14	3	2	8-Hole	20 1/8	9 1/4	2	2 7/8	1 5/8	19 1/4	9 5/8	3 1/4	13/16	3	13 1/2
SCTE16 x 3	16	3	2	8-Hole	22 5/8	10 5/8	2 1/2	3 1/4	2	21 1/4	10 5/8	3 1/4	13/16	3	14 7/8
SCTE18 x 3	18	3	3	10-Hole	25 1/2	12 1/8	2 1/2	3 1/4	2	24 1/4	12 1/8	3 1/4	13/16	3	16
SCTE18 x 3 7/16	18	3 7/16	3	10-Hole	25 1/2	12 1/8	2 1/2	3 1/4	2	24 1/4	12 1/8	3 11/16	13/16	3 3/8	16
SCTE20 x 3	20	3	3	10-Hole	28 1/2	13 1/2	2 1/2	3 3/4	2 1/4	26 1/4	13 1/8	3 1/4	13/16	3	19 1/4
SCTE20 x 3 7/16	20	3 7/16	3	10-Hole	28 1/2	13 1/2	2 1/2	3 3/4	2 1/4	26 1/4	13 1/8	3 11/16	13/16	3 3/8	19 1/4
SCTE24 x 3 7/16	24	3 7/16	4	12-Hole	34 5/8	16 1/2	2 1/2	4 1/8	2 1/2	30 1/4	15 1/8	3 11/16	13/16	3 3/8	20

Part No.	Dimensions														Wt. Lbs.
	M	N	P	Q	R	S	T	U	V	W	X	Y	Z	AB	
SCTE06 x 1 1/2"	4 1/16"	4 7/16"	3 15/32"	5/8"	3 15/16"	2 1/32"	3/16"	7/16"	4 25/64"	-	-	-	7/16"	-	6.7
SCTE09 x 1 1/2"	4 11/16"	6 1/4"	4 15/16"	13/16"	3 13/64"	5 45/64"	1/4"	7/16"	5 23/64"	2 9/16"	-	-	9/16"	-	17.8
SCTE09 x 2	4 11/16"	6 1/4"	4 15/16"	13/16"	3 13/64"	5 45/64"	1/4"	7/16"	5 23/64"	2 9/16"	-	-	9/16"	-	17.7
SCTE10 x 1 1/2"	4 3/4"	6 5/8"	4 1/8"	5/8"	3 3/8"	6 1/8"	1/4"	7/16"	5 45/64"	2 17/32"	-	-	9/16"	-	20.6
SCTE10 x 2	4 3/4"	6 5/8"	4 1/8"	5/8"	3 3/8"	6 1/8"	1/4"	7/16"	5 45/64"	2 17/32"	-	-	9/16"	-	20.5
SCTE12 x 2	6 1/8"	7 15/16"	6 1/4"	15/16"	4 7/64"	6 59/64"	5/16"	9/16"	6 51/64"	3 7/8"	-	-	11/16"	-	33.8
SCTE12 x 2 7/16	6 1/8"	7 15/16"	6 1/4"	15/16"	4 7/64"	6 59/64"	5/16"	9/16"	6 51/64"	3 7/8"	-	-	11/16"	-	33.5
SCTE12 x 3	6 1/8"	7 15/16"	6 1/4"	15/16"	4 7/64"	6 59/64"	5/16"	9/16"	6 51/64"	3 7/8"	-	-	11/16"	-	33.3
SCTE14 x 2 7/16	6 3/4"	8 15/16"	6 23/32"	1 3/32"	4 11/16"	8 27/64"	5/16"	9/16"	7 39/64"	3	-	-	11/16"	-	42.4
SCTE14 x 3	6 3/4"	8 15/16"	6 23/32"	1 3/32"	4 11/16"	8 27/64"	5/16"	9/16"	7 39/64"	3	-	-	11/16"	-	42.2
SCTE16 x 3	7 7/16"	10	8	1 5/8"	4 57/64"	9 17/64"	5/16"	11/16"	8 23/32"	3 3/4"	-	-	11/16"	-	51.1
SCTE18 x 3	8	11	9 1/2"	3 9/16"	2 25/64"	7 37/64"	5/16"	11/16"	10 19/32"	10 47/64"	7 63/64"	2 15/16"	11/16"	-	67.9
SCTE18 x 3 7/16	8	11	9 1/2"	3 9/16"	2 25/64"	7 37/64"	5/16"	11/16"	10 19/32"	10 47/64"	7 63/64"	2 15/16"	11/16"	-	67.7
SCTE20 x 3	9 5/8"	12 3/16"	10 23/32"	4 15/32"	2 13/64"	8 3/16"	3/8"	11/16"	11 23/32"	11 63/64"	9 1/32"	3 11/32"	13/16"	-	96.9
SCTE20 x 3 7/16	9 5/8"	12 3/16"	10 23/32"	4 15/32"	2 13/64"	8 3/16"	3/8"	11/16"	11 23/32"	11 63/64"	9 1/32"	3 11/32"	13/16"	-	96.7
SCTE24 x 3 7/16	10	14 1/4"	13 23/32"	7 19/32"	31/32"	5 33/64"	3/8"	11/16"	10 7/8"	13 55/64"	13 1/8"	9 7/32"	▲13/16"	3 5/16"	133.0

Notes: Browning trough ends are drilled to fit CEMA Standard Troughs. The center holes are drilled to fit Browning screw conveyor drives.  
▲2, "Z" holes in bottom flange only; no holes in top flange.

Each Series 3000 OtN can be ordered with a Tapered Bushed Output. This “33B” mounting configuration will include the appropriate bushing kit unassembled when a bore is defined at order entry. The table below shows the various stocked bushing bores for each OtN frame that can be specified. Each bushing kit is supplied with bushing, hardware for mounting and a stabilizer ring. If bushings are required as a spare or bore changed in the field, refer to the OtN 3000 frame and select the required kit from below.



OtN Frame	Meas. Unit	Bushing Number	Bore <sup>1</sup>	Shaft Keyseat Required	Type
31	Inch	105TBP100	1"	1/4 x 1/8 x 2 1/2	2
		105TBP103	1 3/16"	1/4 x 1/8 x 2 1/2	2
		105TBP104	1 1/4"	1/4 x 1/8 x 2 1/2	2
		105TBP105	1 5/16"	5/16 x 5/32 x 2 1/2	2
	Metric *	105TBP30MM	30 mm	8 x 3.5 x 65 (mm)	2
32 & 33	Inch	107TBP105	1 5/16"	5/16 x 5/32 x 3 7/8	2
		107TBP106	1 3/8"	5/16 x 5/32 x 3 7/8	2
		107TBP107	1 7/16"	3/8 x 3/16 x 3 7/8	2
	Metric *	107TBP30MM	30 mm	8 x 3.5 x 100 (mm)	2
		107TBP35MM	35 mm	10 x 4 x 100 (mm)	2
33A	Inch	115TBP107	1 7/16	3/8 x 3/16 x 4 1/8	2
		115TBP108	1 1/2	3/8 x 3/16 x 4 1/8	2
		115TBP110	1 5/8	3/8 x 3/16 x 4 1/8	2
		115TBP111	1 11/16	3/8 x 3/16 x 4 1/8	2
		115TBP112	1 3/4	3/8 x 3/16 x 4 1/8	2
		115TBP114	1 7/8	1/2 x 1/4 x 4 1/8	2
	Metric *	115TBP115	1 15/16	1/2 x 1/4 x 4 1/8	2
		115TBP40MM	40 mm	12 x 4 x 105 (mm)	2
		115TBP45MM	45 mm	14 x 4.5 x 105 (mm)	2
34	Inch	115TBP111	1 11/16	3/8 x 3/16 x 4 1/8	2
		115TBP112	1 3/4	3/8 x 3/16 x 4 1/8	2
		115TBP114	1 7/8	1/2 x 1/4 x 4 1/8	2
		115TBP115	1 15/16	1/2 x 1/4 x 4 1/8	2
		Metric *	115TBP45MM	45 mm	14 x 4.5 x 105 (mm)

OtN Frame	Meas. Unit	Bushing Number	Bore <sup>1</sup>	Shaft Keyseat Required	Type
35	Inch	207TBP200	2	1/2 x 1/4 x 5 1/8	2
		207TBP202	2 1/8	1/2 x 1/4 x 5 1/8	2
		207TBP203	2 3/16	1/2 x 1/4 x 5 1/8	2
		207TBP204	2 1/4	1/2 x 1/4 x 5 1/8	2
		207TBP207	2 7/16	5/8 x 5/16 x 5 1/8	2
	Metric *	207TBP50MM	50 mm	14 x 4.5 x 130 (mm)	2
		207TBP60MM	60 mm	18 x 5.5 x 130 (mm)	2
36	Inch	215TBP207	2 7/16	5/8 X 5/16 X 5 5/8	2
		215TBP208	2 1/2	5/8 X 5/16 X 5 5/8	2
		215TBP211	2 11/16	5/8 X 5/16 X 5 5/8	2
		215TBP215	2 15/16	3/4 X 3/8 X 5 5/8	2
	Metric *	215TBP60MM	60 mm	18 x 5.5 x 140 (mm)	2
		215TBP70MM	70 mm	20 x 6 x 140 (mm)	2
37	Inch	307TBP214	2 7/8	3/4 x 3/8 x 6 3/4	2
		307TBP215	2 15/16	3/4 x 3/8 x 6 3/4	2
		307TBP300	3	3/4 x 3/8 x 6 3/4	2
		307TBP306	3 3/8	7/8 x 7/16 x 6 3/4	2
		307TBP307	3 7/16	7/8 x 7/16 x 6 3/4	2
		Metric *	307TBP75MM	75 mm	20 x 6 x 170 (mm)
	307TBP80MM		80 mm	22 x 7 x 170 (mm)	2
	307TBP85MM	85 mm	22 x 7 x 170 (mm)	2	
38	Inch	315TBP215	2 15/16	3/4 x 3/8 x 7 15/16	2
		315TBP300	3	3/4 x 3/8 x 7 15/16	2
		315TBP303	3 3/16	3/4 x 3/8 x 7 15/16	2
		315TBP307	3 7/16	7/8 x 7/16 x 15/16	2
		315TBP315	3 15/16	1 x 1/2 x 7 15/16	2
	Metric *	315TBP90MM	90mm	25 x 7 x 190 (mm)	2

<sup>1</sup> Bushing bore shown must be selected by customer based on complete application details.  
 \* Metric bushings have metric bores and require metric keyseats as shown in mm.

## AGMA Application Classifications

Application	Service Factor			Application	Service Factor		
	Up to 3 hrs/day	Up to 10 hrs/day	Over 10 hrs/day		Up to 3 hrs/day	Up to 10 hrs/day	Over 10 hrs/day
<b>Agitators (Mixers)</b>				<b>Cranes (Continued)</b>			
Pure Liquids	—	1.00	1.25	Boom Hoist	Refer to Application Engineering		
Liquids & Solids	1.00	1.25	1.50	Trolley Drive	Refer to Application Engineering		
Liquids - Variable Density	1.00	1.25	1.50	(Gantry Drive)			
				(Traction Drive)	Refer to Application Engineering		
<b>Blowers</b>				Mill Duty			
Centrifugal	1.00	1.25	—	Main	Refer to Application Engineering		
Lobe	1.00	1.25	1.50	Auxiliary	Refer to Application Engineering		
Vane	—	1.00	1.25	Bridge & Trolley Travel	Refer to Application Engineering		
<b>Brewing and Distilling</b>				Industrial Duty			
Bottling Machinery	—	1.00	1.25	Main	1.25	1.50	1.75
Brew Kettles, Continuous Duty	—	1.00	1.25	Auxiliary	Refer to Application Engineering		
Cookers - Continuous Duty	—	1.00	1.25	Bridge & Trolley Travel	Refer to Application Engineering		
Mash Tubs - Continuous Duty	—	1.00	1.25				
Scale Hoppers, Frequent Starts	1.00	1.25	1.50	<b>Crusher</b>			
				Stone or Ore	1.50	1.75	2.00
<b>Can Filling Machines</b>	—	1.00	1.25	<b>Dredges</b>			
<b>Car Dumpers</b>	1.25	1.50	1.75	Cable Reels	1.00	1.25	1.50
<b>Car Pullers</b>	1.00	1.25	1.50	Conveyors	1.00	1.25	1.50
<b>Clarifiers</b>	—	1.00	1.25	Cutter Head Drives	1.25	1.50	1.75
<b>Classifiers</b>	1.00	1.25	1.50	Pumps	1.00	1.25	1.50
<b>Clay Working Industry</b>				Screen Drives	1.25	1.50	1.75
Brick Press	1.25	1.50	1.75	Stackers	1.00	1.25	1.50
Briquette Machine	1.25	1.50	1.75	Winches	1.00	1.25	1.50
Pug Mill	1.00	1.25	1.50	<b>Elevators</b>			
<b>Compactors</b>	1.50	1.75	2.00	Bucket	1.00	1.25	1.50
<b>Compressors</b>				Centrifugal Discharge	—	1.00	1.25
Centrifugal	—	1.00	1.25	Escalators	Refer to Application Engineering		
Lobe	1.00	1.25	1.50	Freight	Refer to Application Engineering		
Reciprocating, Multi - Cylinder	1.00	1.25	1.50	Gravity Discharge	—	1.00	1.25
Reciprocating, Single - Cylinder	1.25	1.50	1.75	<b>Extruders</b>			
<b>Conveyors - General Purpose</b>				General	1.25	1.25	1.25
Uniformly Loaded or Fed	—	1.00	1.25	Plastics			
Not Uniformly Fed	1.00	1.25	1.50	(a) Variable Speed Drive	1.50	1.50	1.50
Reciprocating or Shaker	1.25	1.50	1.75	(b) Fixed Speed Drive	1.75	1.75	1.75
<b>Cranes</b>				Rubber			
Dry Dock				(a) Continuous Screw Operation	1.50	1.50	1.50
Main Hoist	1.25	1.50	1.75	(b) Intermittent Screw Operation	1.75	1.75	1.75
Auxiliary	1.25	1.50	1.75	<b>Fans</b>			
Boom Hoist	1.25	1.50	1.75	Centrifugal	—	1.00	1.25
Slewing Drive	1.25	1.50	1.75	Cooling Towers	Refer to Application Engineering		
Traction Drive	1.50	1.50	1.50	Forced Draft	1.25	1.25	1.25
Container				Induced Draft	1.00	1.25	1.50
Main Hoist	Refer to Application Engineering			Industrial & Mine	1.00	1.25	1.50

## AGMA Application Classifications

Application	Service Factor			Application	Service Factor		
	Up to 3 hrs/day	Up to 10 hrs/day	Over 10 hrs/day		Up to 3 hrs/day	Up to 10 hrs/day	Over 10 hrs/day
<b>Feeders</b>				<b>Metal Mills</b>			
Apron	—	1.25	1.50	Draw Bench Carriage & Main Drive	1.00	1.25	1.50
Belt	1.00	1.25	1.50	Runout Table			
Disc	—	1.00	1.25	Non-reversing			
Reciprocating	1.25	1.50	1.75	Group Drives	1.00	1.25	1.50
Screw	1.00	1.25	1.50	Individual Drives	1.50	1.50	1.75
				Reversing	1.50	1.50	1.75
<b>Food Industry</b>				Slab Pushers	1.25	1.25	1.50
Cereal Cooker	—	1.00	1.25	Shears	1.50	1.50	1.75
Dough Mixers	1.00	1.25	1.50	Wire Drawing	1.00	1.25	1.50
Meat Grinders	1.00	1.25	1.50	Wire Winding Machine	1.00	1.25	1.50
Slicers	1.00	1.25	1.50				
				<b>Metal Strip Processing Machinery</b>			
<b>Generators and Exciters</b>	—	1.00	1.25	Bridles	1.25	1.25	1.50
				Coilers & Uncoilers	1.00	1.00	1.25
<b>Hammer Mills</b>	1.50	1.50	1.75	Edge Trimmers	1.00	1.25	1.50
				Flatteners	1.00	1.25	1.50
<b>Hoists</b>				Loopers (Accumulators)	1.00	1.00	1.00
Heavy Duty	1.25	1.50	1.75	Pinch Rolls	1.00	1.25	1.50
Medium Duty	1.00	1.25	1.50	Scrap Choppers	1.00	1.25	1.50
Skip Hoist	1.00	1.25	1.50	Shears	1.50	1.50	1.75
				Slitters	1.00	1.25	1.50
<b>Laundry Tumblers</b>	1.00	1.25	1.50				
				<b>Mills, Rotary Type</b>			
<b>Laundry Washers</b>	1.00	1.25	1.50	Ball & Rod			
				Spur Ring Gear	1.50	1.50	1.75
<b>Lumber Industry</b>				Helical Ring Gear	1.50	1.50	1.50
Barkers				Direct Connected	1.50	1.50	1.75
- Spindle Feed	1.25	1.25	1.25	Cement Kilns	1.50	1.50	1.50
- Main Drive	1.50	1.50	1.50	Dryers & Coolers	1.50	1.50	1.50
Conveyors							
- Burner	1.25	1.25	1.50	<b>Mixers, Concrete</b>	1.00	1.25	1.50
- Main or Heavy Duty	1.50	1.50	1.50				
- Main Log	1.50	1.50	1.50	<b>Paper Mills</b>			
- Re-Saw, Merry-Go-Round	1.25	1.25	1.50	Agitator (Mixer)	1.50	1.50	1.50
- Slab	1.50	1.50	1.75	Agitator for Pure Liquids	1.25	1.25	1.25
- Transfer	1.25	1.25	1.50	Barkers - Mechanical	1.75	1.75	1.75
Chains				Barking Drums	1.75	1.75	1.75
- Floor	1.50	1.50	1.50	Beater	1.50	1.50	1.50
- Green	1.50	1.50	1.50	Breaker Stack	1.25	1.25	1.25
Cut-Off Saws				❖ Calender	1.25	1.25	1.25
- Chain	1.50	1.50	1.50	Chipper	1.75	1.75	1.75
- Drag	1.50	1.50	1.50	Chip Feeder	1.50	1.50	1.50
Debarking Drums	1.50	1.50	1.75	Coating Rolls	1.25	1.25	1.25
Feeds				Conveyors			
- Edger	1.25	1.25	1.50	Chip, Bark, Chemical	1.25	1.25	1.25
- Gang	1.50	1.50	1.50	Log (Including Slab)	1.75	1.75	1.75
- Trimmer	1.25	1.25	1.50	Couch Rolls	1.25	1.25	1.25
Log Deck	1.50	1.50	1.50	Cutter	1.75	1.75	1.75
Log Hauls - Incline-Well Type	1.50	1.50	1.50	Cylinder Molds	1.25	1.25	1.25
Log Turning Devices	1.50	1.50	1.50	❖ Dryers			
Planner Feed	1.25	1.25	1.25	Paper Machine	1.25	1.25	1.25
Planer Tilting Hoists	1.50	1.50	1.50	Conveyor Type	1.25	1.25	1.25
Rolls - Live-Off Bearing.-Roll Cases	1.50	1.50	1.50	Embosser	1.25	1.25	1.25
Sorting Table	1.25	1.25	1.50	Extruder	1.50	1.50	1.50
Tipple Hoist	1.25	1.25	1.50	Fourdrinier Rolls (Includes Lump Breaker, Dandy Roll, Wire Turning, and Return Rolls)	1.25	1.25	1.25
Transfers				Jordan	1.25	1.25	1.25
- Chain	1.50	1.50	1.50	Kiln Drive	1.50	1.50	1.50
- Causeway	1.50	1.50	1.50	Mt. Hope Roll	1.25	1.25	1.25
Tray Drives	1.25	1.25	1.50				
Veneer Lathe Drives	Refer to Application Engineering						



## AGMA Application Classifications

Application	Service Factor			Application	Service Factor		
	Up to 3 hrs/day	Up to 10 hrs/day	Over 10 hrs/day		Up to 3 hrs/day	Up to 10 hrs/day	Over 10 hrs/day
<b>Paper Mills (Continued)</b>				<b>Rubber Industry</b>			
Paper Rolls	1.25	1.25	1.25	Intensive Internal Mixers			
Platter	1.50	1.50	1.50	(a) Batch Mixers	1.50	1.75	1.75
Presses - Felt & Suction	1.25	1.25	1.25	(b) Continuous Mixers	1.25	1.50	1.50
Pulper	1.50	1.50	1.75	Mixing Mill - 2 Smooth Rolls - (If corrugated rolls are used, then use the same service factors that are used for a Cracker-Warmer)	1.50	1.50	1.50
Pumps - Vacuum	1.50	1.50	1.50	Batch Drop Mill - 2 Smooth Rolls	1.50	1.50	1.50
Reel (Surface Type)	1.25	1.25	1.50	Cracker Warmer - 1 Corrugated Roll	1.75	1.75	1.75
Screens				Cracker - 2 Corrugated Rolls	1.75	1.75	1.75
Chip	1.50	1.50	1.50	Holding, Feed & Blend Mill - 2 Rolls	1.25	1.25	1.25
Rotary	1.50	1.50	1.50	Refiner - 2 Rolls	1.50	1.50	1.50
Vibrating	1.75	1.75	1.75	Calenders	1.50	1.50	1.50
Size Press	1.25	1.25	1.25				
Super Calender (See Note)	1.25	1.25	1.25	<b>Sand Miller</b>	1.00	1.25	1.50
Thickner				<b>Sewage Disposal</b>			
(AC Motor)	1.50	1.50	1.50	Bar Screens	—	1.00	1.25
(DC Motor)	1.25	1.25	1.25	Chemical Feeders	—	1.00	1.25
Washer				Dewatering Screens	1.00	1.25	1.50
(AC Motor)	1.50	1.50	1.50	Scum Breakers	1.00	1.25	1.50
(DC Motor)	1.25	1.25	1.25	Slow or Rapid Mixers	1.00	1.25	1.50
Wind and Unwind Stand	1.00	1.00	1.00	Sludge Collectors	1.00	1.00	1.25
Winders (Surface Type)	1.25	1.25	1.25	Thickeners	1.00	1.25	1.50
❖ Yankee Dryers	1.25	1.25	1.25	Vacuum Filters	1.00	1.25	1.50
<b>Plastics Industry - Primary Processing</b>				<b>Screens</b>			
Intensive Internal Mixers				Air Washing	—	1.00	1.25
(a) Batch Mixers	1.75	1.75	1.75	Rotary - Stone or Gravel	1.00	1.25	1.50
(b) Continuous Mixers	1.50	1.50	1.50	Traveling Water Intake	—	1.00	1.25
Batch Drop Mill - 2 Smooth Rolls	1.25	1.25	1.25				
Continuous Feed, Holding & Blend Mill	1.25	1.25	1.25	<b>Sugar Industry</b>			
Compounding Mills	1.25	1.25	1.25	Beet Slicer	1.50	1.50	1.75
Calenders	1.50	1.50	1.50	Cane Knives	1.50	1.50	1.50
<b>Plastics Industry - Secondary Processing</b>				Crushers	1.50	1.50	1.50
Blow Molders	1.50	1.50	1.50	Mills (Low Speed End)	1.50	1.50	1.50
Coating	1.25	1.25	1.25				
Film	1.25	1.25	1.25	<b>Textile Industry</b>			
Pipe	1.25	1.25	1.25	Batchers	1.00	1.25	1.50
Pre-Plasticizers	1.50	1.50	1.50	Calenders	1.00	1.25	1.50
Rods	1.25	1.25	1.25	Cards	1.00	1.25	1.50
Sheet	1.25	1.25	1.25	Dry Cans	1.00	1.25	1.50
Tubing	1.25	1.25	1.50	Dryers	1.00	1.25	1.50
<b>Pullers - Barge Haul</b>	1.00	1.50	1.75	Dyeing Machinery	1.00	1.25	1.50
<b>Pumps</b>				Looms	1.00	1.25	1.50
Centrifugal	—	1.00	1.25	Mangles	1.00	1.25	1.50
Proportioning	1.00	1.25	1.50	Nappers	1.00	1.25	1.50
Reciprocating				Pads	1.00	1.25	1.50
Single Acting, 3 or more cylinders	1.00	1.25	1.50	Slashers	1.00	1.25	1.50
Double Acting, 2 or more cylinders	1.00	1.25	1.50	Soapers	1.00	1.25	1.50
Rotary				Spinners	1.00	1.25	1.50
- Gear	—	1.00	1.50	Tenter Frames	1.00	1.25	1.50
- Lobe	—	1.00	1.25	Washers	1.00	1.25	1.50
- Vane	—	1.00	1.25	Winders	1.00	1.25	1.50

❖ Anti-friction bearings only.

Note: A service factor of 1.0 may be applied at the base of a super calender, operating over a speed range where part of the range is constant horsepower and part of the range is constant torque, provided that the constant horsepower part is greater than 1.5 to 1. A service factor of 1.25 is applicable to super calenders operating over the entire speed range at constant torque, or where the constant horsepower speed range is less than 1.5 to 1.





# Specifications

# OtN SERIES 3000

## Motor rpm 1750

OtN Series

Gear Frame																			
Nom. RPM	Nom. Ratio	31		32		33	34	35	36	37	38								
				Double	Triple														
493	3.55			3.71 21.23	3242 2723														
389	4.5			4.68 18.59	3242 3008														
350	5	5.1 5.53	3132 975							RO	RO								
313	5.6			5.60 16.27	3242 3150					RO	RO								
278	6.3	6.43 4.83	3132 1074	6.61 13.95	3242 3188					RO	RO								
246	7.1	7.23 4.5	3132 1125	7.05 13.08	3242 3188					RO	RO								
219	8	7.62 4.37	3132 1151	7.97 11.57	3242 3188					RO	RO								
194	9	8.62 4.02	3132 1198	8.83 10.44	3242 3187					RO	RO								
175	10	9.72 3.73	3132 1253	10.10 9.13	3242 3188	9.78 15.62	3363 5172	9.51 25.2	3473 8113	9.47 54.65	3583 17520	9.81 64.96	3693 21573	10.1 92.68	3703 31689				
156	11.2	11 3.45	3132 1312	11.60 7.95	3242 3188							10.9 61.20	3693 22583	11.5 85.80	3703 33403	11.1 120	3823 45093		
140	12.5	12.5 3.18	3132 1374	12.40 7.44	3242 3190	12.3 13.31	3363 5542	12.3 23.08	3473 9610	12.3 45.48	3583 18938	12.7 55.94	3693 24051	12.3 82.31	3703 34274	12.4 120	3823 50374		
125	14	14.3 2.91	3132 1439	14.10 6.54	3242 3188	14.8 12.06	3363 6042	15.2 22.45	3473 11552	14.9 38.69	3583 19516	14.6 51.34	3693 25375	13.7 72.29	3703 33528	13.9 120	3823 56468		
109	16	16.1 2.69	3132 1497	15.60 5.91	3242 3188	16.1 6.07	3243 3308	16.1 11.68	3363 6366	15.5 22.27	3473 11686	15.5 35.13	3583 18434	16 48.54	3693 26292	15.5 71.65	3703 37597	15.5 120	3823 62967
97	18	17.1 2.61	3132 1543	17.70 5.21	3242 3188			18.6 10.01	3363 6303	17.5 19.65	3473 11641	18.7 32.7	3583 20701	17.9 46.68	3693 28287	17.6 68.88	3703 41040	17.8 120	3823 72311
88	20	20.3 2.31	3132 1621	19.70 4.68	3242 3188	20.4 5.11	3243 3529	20.3 9.92	3363 6817	20.1 18.14	3473 12343	20 29.43	3583 19926	19.2 48.50	3693 31524	19.9 70.18	3703 47279	19.6 120	3823 79623
78	22.4	21.5 2.24	3132 1665	22.20 4.15	3242 3185	22.9 4.72	3243 3659	23.3 8.61	3363 6791	21.3 15.9	3473 11465	23.6 26.36	3583 21060	21.4 47.99	3693 34767	22.6 70.01	3703 53564	22.2 120	3823 90185
70	25	24.6 2.03	3132 1727	26.00 3.55	3242 3191	24.1 4.53	3243 3696	24.3 8.48	3363 6976	24.8 15.23	3473 12787	24.3 25.63	3583 21084	25 44.31	3693 37501	24 69.80	3703 56711	25.3 120	3823 102779
63	28	27.4 1.90	3132 1800	28.70 3.21	3242 3185	27.3 4.08	3243 3771	28.7 7.47	3363 7258	28.6 13.43	3473 13003	27.1 23.4	3583 21468	28.6 37.44	3693 36250	26.9 58.43	3703 53210	28.7 107.13	3823 104086
56	31.5	30.7 1.75	3132 1857	31.50 2.93	3242 3191	30.8 3.69	3243 3848	30.6 6.89	3363 7137	31.5 12.61	3473 13447	30.5 21.2	3583 21890	31.4 35.02	3693 37226	30.4 54.12	3703 55697	32.4 102.97	3823 112942
49	35.5	35.6 1.58	3132 1945	36.80 2.51	3242 3194	34.8 3.3	3243 3888	34.6 5.93	3363 6946	34.8 11.41	3473 13442	34 19.34	3583 22261	35 32.08	3693 38011	34.4 50.08	3703 58321	36.4 91.49	3823 112739
44	40	39.1 1.46	3132 1974			39.5 2.92	3243 3905	38.3 5.37	3363 6963	39.9 9.96	3473 13453	38.6 17.11	3583 22358	39.2 29.26	3693 38830	38.1 46.88	3703 60467	40.6 87.17	3823 119810
39	45	44.8 1.00	3132 1549			45.2 2.56	3243 3917	43.7 4.72	3363 6983	44.1 9.01	3473 13451	42.6 15.55	3583 22426	44.1 26.16	3693 39055	42.5 43.69	3703 62860	45.8 79.67	3823 123527
35	50	49.4 1.00	3132 1708			51 2.27	3243 3919	50.3 4.11	3363 6999	50.6 7.85	3473 13447	49.8 13.37	3583 22540	47.8 24.20	3693 39160	47.7 40.56	3703 65497	50.1 70.36	3823 119334
31	56					54.1 2.14	3243 3919	53.8 3.85	3363 7012	57 7.06	3473 13623	55.5 12.03	3583 22603	54.4 21.34	3693 39300	55.9 36.50	3703 69073	57 61.84	3823 119329
28	63					64.3 1.81	3243 3940	61 3.41	3363 7042	61.9 6.58	3473 13789	62.4 10.73	3583 22667	60.1 19.37	3693 39410	63.2 32.99	3703 70583	64.3 54.82	3823 119330
25	71					68 1.71	3243 3936	67.8 3.07	3363 7046	69 6.01	3473 14039	70.6 9.52	3583 22753	69.6 16.79	3693 39561	68.9 30.73	3703 71678	72.2 48.82	3823 119326
22	80					77.7 1.5	3243 3946	77 2.71	3363 7064	77.5 5.37	3473 14089	80.6 8.36	3583 22811	75.9 15.43	3693 39647	80.4 26.78	3703 72890	80.5 43.79	3823 119336
19	90					86.7 1.35	3243 3962	85.7 2.44	3363 7079	87.7 4.76	3473 14132	86.5 7.81	3583 22870	85.3 13.77	3693 39764	87.4 24.68	3703 73023	90.8 38.83	3823 119359
18	100					97.2 1.21	3243 3982	96.4 2.17	3363 7082	95.4 4.38	3473 14146	101 6.71	3583 22943	95.1 12.38	3693 39857	98 22.08	3703 73253	102 34.56	3823 119337
16	112					113 1.04	3243 3978	113 1.86	3363 7115	108 3.88	3473 14186	109 6.23	3583 22989	108 10.93	3693 39962	109 19.90	3703 73431	115 30.65	3823 119325
14	125					124 0.95	3243 3988	125 1.68	3363 7109	124 3.39	3473 14231	121 5.62	3583 23021	124 9.54	3693 40047	123 17.68	3703 73619	128 27.54	3823 119337
12.5	140					142 0.83	3243 3990	137 1.54	3363 7142	139 3.03	3473 14258	134 5.09	3583 23090	135 8.78	3693 40126	135 16.14	3703 73763	137 25.73	3823 119334
10.9	160					156 0.76	3243 4014	160 1.32	3363 7150	154 2.74	3473 14285	159 4.3	3583 23146	157 7.57	3693 40234	152 14.37	3703 73944	154 22.89	3823 119335

Note: If shaded, Mechanical HP shown may exceed thermal HP limit. Refer to Page B-143-144

R.O. Refer application details to Marketing

Exact ratio	Gear Frame
Input H.P.	Output Torque



# Specifications

OtN  
SERIES 3000

## Motor rpm 1450

OtN Series

Gear Frame																			
Nom. RPM	Nom. Ratio	31		32		33	34	35	36	37	38	38							
				Double	Triple							100	45352						
408	3.55			3.71 18.48	3242 2861														
322	4.5			4.68 16.18	3242 3160														
290	5	5.1 4.81	3132 1024							RO	RO								
259	5.6			5.60 13.64	3242 3187					RO	RO								
230	6.3	6.43 4.21	3132 1130	6.61 11.56	3242 3188					RO	RO								
204	7.1	7.23 3.92	3132 1183	7.05 10.84	3242 3189					RO	RO								
181	8	7.62 3.8	3132 1208	7.97 9.59	3242 3189					RO	RO								
161	9	8.62 3.5	3132 1259	8.83 8.65	3242 3187					RO	RO								
145	10	9.72 3.25	3132 1318	10.10 7.56	3242 3186	9.78 13.6	3363 5434	9.51 21.23	3473 8249	9.47 47.56	3583 19577	9.81 55.21	3693 22129	10.1 80.66	3703 33285				
129	11.2	11 3	3132 1377	11.60 6.59	3242 3190							10.9 53.26	3693 23719	11.5 74.67	3703 35085	100 45352			
116	12.5	12.5 2.77	3132 1445	12.40 6.16	3242 3187	12.3 11.59	3363 5825	12.3 17.72	3473 8905	12.3 39.58	3583 19891	12.7 48.69	3693 25265	12.3 71.64	3703 36003	12.4 100	3823 50663		
104	14	14.3 2.53	3132 1510	14.10 5.42	3242 3189	14.8 10.01	3363 6053	15.2 15.76	3473 9788	14.9 32.82	3583 19980	14.6 44.69	3693 26659	13.7 62.92	3703 35219	13.9 100	3823 56792		
91	16	16.1 2.34	3132 1572	15.60 4.90	3242 3190	16.1 5.26	3243 3460	16.1 9.05	3363 5953	15.5 15.58	3473 9867	15.5 30.58	3583 19366	16 42.25	3693 27620	15.5 62.36	3703 39492	15.5 100	3823 63329
81	18	17.1 2.27	3132 1620	17.70 4.32	3242 3191			18.6 8.03	3363 6102	17.5 13.85	3473 9703	18.7 27.49	3583 21003	17.9 40.63	3693 29715	17.6 59.95	3703 43110	17.8 100	3823 72727
73	20	20.3 2.01	3132 1703	19.70 3.88	3242 3189	20.4 4.45	3243 3709	20.3 7.76	3363 6436	20.1 12.98	3473 10660	20 25.61	3583 20927	19.2 41.74	3693 32744	19.9 61.08	3703 49662	19.6 100	3823 80081
65	22.4	21.5 1.95	3132 1749	22.20 3.44	3242 3187	22.9 4.1	3243 3836	23.3 6.81	3363 6483	21.3 12.07	3473 10504	23.6 22.31	3583 21512	21.4 41.77	3693 36522	22.6 61.02	3703 56345	22.2 100	3823 90703
58	25	24.6 1.77	3132 1817	26.00 2.94	3242 3190	24.1 3.93	3243 3870	24.3 6.75	3363 6702	24.8 11.2	3473 11349	24.3 22.28	3583 22120	25 37.74	3693 38549	24 60.75	3703 59570	25.3 100	3823 103370
52	28	27.4 1.65	3132 1886	28.70 2.66	3242 3186	27.3 3.48	3243 3882	28.7 5.87	3363 6883	28.6 10.14	3473 11849	27.1 20.07	3583 22222	28.6 32.59	3693 38082	26.9 50.85	3703 55888	28.7 93.25	3823 109346
46	31.5	30.7 1.52	3132 1947	31.50 2.43	3242 3194	30.8 3.09	3243 3888	30.6 5.5	3363 6876	31.5 9.48	3473 12201	30.5 17.9	3583 22306	31.4 30.28	3693 38847	30.4 47.10	3703 58502	32.4 89.68	3823 118717
41	35.5	35.6 1.38	3132 2050	36.80 2.08	3242 3194	34.8 2.75	3243 3910	34.6 4.93	3363 6969	34.8 8.84	3473 12569	34 16.12	3583 22393	35 27.27	3693 38997	34.4 43.58	3703 61252	36.4 79.68	3823 118501
36	40	39.1 1.26	3132 2056			39.5 2.43	3243 3922	38.3 4.47	3363 6995	39.9 8.03	3473 13091	38.6 14.25	3583 22474	39.2 24.43	3693 39128	38.1 40.80	3703 63512	40.6 75.88	3823 125871
32	45	44.8 0.83	3132 1552			45.2 2.13	3243 3934	43.7 3.93	3363 7017	44.1 7.49	3473 13496	42.6 12.95	3583 22540	44.1 21.79	3693 39262	42.5 38.02	3703 66020	45.8 69.34	3823 129754
29	50	49.4 0.83	3132 1711			51 1.89	3243 3938	50.3 3.42	3363 7029	50.6 6.78	3473 14017	49.8 11.13	3583 22646	47.8 20.15	3693 39353	47.7 35.30	3703 68796	50.1 58.3	3823 119338
26	56					54.1 1.78	3243 3935	53.8 3.2	3363 7034	57 6.04	3473 14066	55.5 10.02	3583 22721	54.4 17.77	3693 39497	55.9 31.74	3703 72492	57 51.24	3823 119332
23	63					64.3 1.5	3243 3941	61 2.83	3363 7053	61.9 5.56	3473 14062	62.4 8.93	3583 22767	60.1 16.12	3693 39583	63.2 28.17	3703 72741	64.3 45.42	3823 119325
20	71					68 1.42	3243 3945	67.8 2.55	3363 7064	69 5	3473 14096	70.6 7.92	3583 22846	69.6 13.97	3693 39726	68.9 25.90	3703 72911	72.2 40.45	3823 119324
18	80					77.7 1.25	3243 3968	77 2.25	3363 7079	77.5 4.47	3473 14154	80.6 6.96	3583 22920	75.9 12.84	3693 39818	80.4 22.28	3703 73189	80.5 36.28	3823 119326
16	90					86.7 1.12	3243 3967	85.7 2.03	3363 7108	87.7 3.95	3473 14154	86.5 6.49	3583 22937	85.3 11.45	3693 39905	87.4 20.54	3703 73347	90.8 32.17	3823 119346
15	100					97.2 1	3243 3971	96.4 1.81	3363 7129	95.4 3.64	3473 14188	101 5.58	3583 23027	95.1 10.29	3693 39982	98 18.37	3703 73554	102 28.63	3823 119315
13	112					113 0.86	3243 3971	113 1.54	3363 7110	108 3.22	3473 14209	109 5.18	3583 23069	108 9.09	3693 40111	109 16.55	3703 73705	115 25.4	3823 119345
12	125					124 0.79	3243 4002	125 1.4	3363 7150	124 2.81	3473 14236	121 4.67	3583 23087	124 7.93	3693 40176	123 14.71	3703 73925	128 22.82	3823 119343
10.4	140					142 0.69	3243 4003	137 1.28	3363 7165	139 2.51	3473 14255	134 4.23	3583 23159	135 7.30	3693 40265	135 13.42	3703 74022	137 21.32	3823 119338
9.1	160					156 0.63	3243 4015	160 1.1	3363 7191	154 2.27	3473 14283	159 3.57	3583 23192	157 6.29	3693 40348	152 11.95	3703 74214	154 18.97	3823 119361

Note: If shaded, Mechanical HP shown may exceed thermal HP limit. Refer to Page B-143-144

R.O. Refer application details to Marketing

Exact ratio	Gear Frame
Input H.P.	Output Torque

## Motor rpm 1160

Gear Frame													
Nom. RPM	Nom. Ratio	31		32		33	34	35	36	37	38		
				Double	Triple								
327	3.55			3.71 3242 16.01 3098									
258	4.5			4.68 3242 13.04 3183									
232	5	5.1 3132 4.17 1109								RO	RO		
207	5.6			5.60 3242 10.91 3187						RO	RO		
184	6.3	6.43 3132 3.64 1221		6.61 3242 9.25 3189						RO	RO		
163	7.1	7.23 3132 3.39 1278		7.05 3242 8.67 3188						RO	RO		
145	8	7.62 3132 3.29 1308		7.97 3242 7.67 3188						RO	RO		
129	9	8.62 3132 3.03 1362		8.83 3242 6.92 3187						RO	RO		
116	10	9.72 3132 2.81 1425		10.10 3242 6.05 3187		9.78 3363 11.78 5884	9.51 3473 17.42 8461	9.47 3583 39.91 19303	9.81 3693 44.17 22130	10.1 3703 69.89 36051			
104	11.2	11 3132 2.6 1492		11.60 3242 5.27 3189					10.9 3693 44.17 24589	11.5 3703 64.69 37994	11.1 3823 80 45352		
93	12.5	12.5 3132 2.4 1565		12.40 3242 4.93 3189		12.3 3363 9.62 6043	12.3 3473 15.36 9649	12.3 3583 33.05 20762	12.7 3693 42.17 27352	12.3 3703 62.07 38991	12.4 3823 80 50663		
83	14	14.3 3132 2.2 1641		14.10 3242 4.33 3184		14.8 3363 8.43 6372	15.2 3473 14.71 11419	14.9 3583 26.8 20394	14.6 3693 38.70 28857	13.7 3703 54.51 38140	13.9 3823 80 56792		
73	16	16.1 3132 2.03 1705		15.60 3242 3.92 3190	16.1 3243 4.55 3741	16.1 3363 8.1 6660	15.5 3473 14.59 11550	15.5 3583 26.49 20970	16 3693 36.59 29900	15.5 3703 54.02 42763	15.5 3823 80 63329		
64	18	17.1 3132 1.97 1757		17.70 3242 3.45 3185		18.6 3363 6.78 6441	17.5 3473 12.58 11243	18.7 3583 22.2 21202	17.9 3693 35.19 32170	17.6 3703 51.94 46687	17.8 3823 80 72727		
58	20	20.3 3132 1.74 1842		19.70 3242 3.10 3185	20.4 3243 3.7 3855	20.3 3363 6.64 6884	20.1 3473 12.03 12349	20 3583 21.56 22022	19.2 3693 36.16 35458	19.9 3703 52.91 53774	19.6 3823 80 80081		
52	22.4	21.5 3132 1.69 1895		22.20 3242 2.75 3184	22.9 3243 3.32 3883	23.3 3363 5.74 6830	21.3 3473 10.46 11379	23.6 3583 18.66 22491	21.4 3693 35.16 38428	22.6 3703 52.71 60839	22.2 3823 80 90704		
46	25	24.6 3132 1.53 1963		26.00 3242 2.35 3187	24.1 3243 3.16 3889	24.3 3363 5.6 6950	24.8 3473 10.09 12780	24.3 3583 18 22339	25 3693 30.46 38891	24 3703 52.63 64510	25.3 3823 80 103370		
41	28	27.4 3132 1.42 2029		28.70 3242 2.13 3189	27.3 3243 2.8 3904	28.7 3363 4.76 6977	28.6 3473 8.9 13000	27.1 3583 16.2 22422	28.6 3693 26.68 38970	26.9 3703 44.05 60517	28.7 3823 80 117261		
37	31.5	30.7 3132 1.27 2034		31.50 3242 1.94 3187	30.8 3243 2.49 3917	30.6 3363 4.48 7001	31.5 3473 8.36 13449	30.5 3583 14.44 22493	31.4 3693 24.43 39177	30.4 3703 40.81 63361	32.4 3823 78.65 130145		
33	35.5	35.6 3132 1.11 2061		36.80 3242 1.66 3186	34.8 3243 2.21 3928	34.6 3363 3.97 7015	34.8 3473 7.66 13614	34 3583 13 22574	35 3693 21.98 39290	34.4 3703 37.75 66322	36.4 3823 69.88 129908		
29	40	39.1 3132 1.01 2060			39.5 3243 1.95 3934	38.3 3363 3.59 7022	39.9 3473 6.82 13898	38.6 3583 11.49 22651	39.2 3693 19.69 39420	38.1 3703 35.35 68786	40.6 3823 63.16 130964		
26	45	44.8 3132 0.66 1542			45.2 3243 1.71 3947	43.7 3363 3.16 7053	44.1 3473 6.21 13987	42.6 3583 10.44 22714	44.1 3693 17.55 39527	42.5 3703 32.94 71498	45.8 3823 56.16 131364		
23	50	49.4 3132 0.66 1701			51 3243 1.52 3959	50.3 3363 2.75 7065	50.6 3473 5.45 14084	49.8 3583 8.96 22789	47.8 3693 16.23 39621	47.7 3703 29.64 72207	50.1 3823 46.64 119338		
21	56				54.1 3243 1.43 3951	53.8 3363 2.58 7089	57 3473 4.85 14119	55.5 3583 8.06 22846	54.4 3693 14.30 39730	55.9 3703 25.58 73029	57 3823 40.99 119326		
18	63				64.3 3243 1.21 3974	61 3363 2.28 7103	61.9 3473 4.48 14163	62.4 3583 7.19 22914	60.1 3693 12.98 39841	63.2 3703 22.69 73238	64.3 3823 36.34 119338		
16	71				68 3243 1.14 3959	67.8 3363 2.05 7098	69 3473 4.02 14166	70.6 3583 6.37 22968	69.6 3693 11.24 39954	68.9 3703 20.86 73403	72.2 3823 32.36 119324		
15	80				77.7 3243 1 3968	77 3363 1.81 7118	77.5 3473 3.59 14210	80.6 3583 5.6 23052	75.9 3693 10.32 40004	80.4 3703 17.94 73665	80.5 3823 29.03 119351		
13	90				86.7 3243 0.9 3985	85.7 3363 1.63 7134	87.7 3473 3.18 14243	86.5 3583 5.22 23061	85.3 3693 9.21 40123	87.4 3703 16.53 73785	90.8 3823 25.73 119319		
12	100				97.2 3243 0.8 3971	96.4 3363 1.45 7139	95.4 3473 2.93 14276	101 3583 4.49 23161	95.1 3693 8.27 40167	98 3703 14.77 73925	102 3823 22.91 119346		
10	112				113 3243 0.69 3982	113 3363 1.24 7156	108 3473 2.59 14286	109 3583 4.16 23158	108 3693 7.30 40265	109 3703 13.31 74095	115 3823 20.32 119345		
9	125				124 3243 0.63 3990	125 3363 1.12 7150	124 3473 2.26 14312	121 3583 3.75 23174	124 3693 6.37 40341	123 3703 11.82 74252	128 3823 18.25 119304		
8.3	140				142 3243 0.55 3989	137 3363 1.03 7207	139 3473 2.02 14340	134 3583 3.4 23268	135 3693 5.86 40403	135 3703 10.79 74394	137 3823 17.06 119366		
7.3	160				156 3243 0.5 3984	160 3363 0.88 7191	154 3473 1.82 14314	159 3583 2.87 23306	157 3693 5.05 40492	152 3703 9.60 74524	154 3823 15.17 119313		

Note: If shaded, Mechanical HP shown may exceed thermal HP limit. Refer to Page B-143-144

R.O. Refer application details to Marketing

Exact ratio	Gear Frame
Input H.P.	Output Torque

Gear Frame													
Nom. RPM	Nom. Ratio	31		32		33	34	35	36	37	38		
				Double	Triple								
245	3.55			3.71	3242								
				12.31	3176								
193	4.5			4.68	3242								
				9.79	3186								
174	5	5.1	3132							RO		RO	
		3.41	1209										
155	5.6			5.60	3242					RO		RO	
				8.19	3190								
138	6.3	6.43	3132	6.61	3242					RO		RO	
		2.98	1333	6.93	3186								
123	7.1	7.23	3132	7.05	3242					RO		RO	
		2.78	1398	6.50	3187								
109	8	7.62	3132	7.97	3242					RO		RO	
		2.7	1431	5.75	3187								
97	9	8.62	3132	8.83	3242					RO		RO	
		2.48	1487	5.19	3187								
87	10	9.72	3132	10.10	3242	9.78	3363	9.51	3473	9.47	3583	9.81	3693
		2.3	1555	4.54	3189	9.11	6067	13.07	8464	30.73	19817	33.12	22125
78	11.2	11	3132	11.60	3242							10.9	3693
		2.13	1629	3.95	3187							33.12	24583
70	12.5	12.5	3132	12.40	3242	12.3	3363	12.3	3473	12.3	3583	12.7	3693
		1.96	1704	3.70	3191	7.32	6131	12.57	10528	25.21	21115	33.12	28643
62	14	14.3	3132	14.10	3242	14.8	3363	15.2	3473	14.9	3583	14.6	3693
		1.8	1790	3.25	3187	6.47	6521	11.3	11696	21.29	21601	31.68	31496
54	16	16.1	3132	15.60	3242	16.1	3243	15.5	3473	15.5	3583	16	3693
		1.66	1859	2.94	3190	3.53	3870	6.29	6896	11.05	11663	20.88	22039
48	18	17.1	3132	17.70	3242	18.6	3363	17.5	3473	18.7	3583	17.9	3693
		1.61	1915	2.59	3188	5.22	6612	9.82	11702	16.81	21406	28.34	34544
44	20	20.3	3132	19.70	3242	20.4	3243	20.3	3363	20.1	3473	20	3583
		1.42	2005	2.33	3192	2.81	3904	5.05	6981	9.2	12592	16.45	22404
39	22.4	21.5	3132	22.20	3242	22.9	3243	23.3	3363	21.3	3473	23.6	3583
		1.35	2019	2.06	3180	2.51	3914	4.31	6838	8.37	12140	14.05	22579
35	25	24.6	3132	26.00	3242	24.1	3243	24.3	3363	24.8	3473	24.3	3583
		1.19	2036	1.76	3182	2.39	3922	4.23	7000	7.94	13409	13.62	22537
31	28	27.4	3132	28.70	3242	27.3	3243	28.7	3363	28.6	3473	27.1	3583
		1.08	2058	1.60	3193	2.11	3923	3.6	7036	7.08	13789	12.25	22606
28	31.5	30.7	3132	31.50	3242	30.8	3243	30.6	3363	31.5	3473	30.5	3583
		0.97	2071	1.46	3198	1.88	3943	3.38	7043	6.48	13900	10.92	22680
25	35.5	35.6	3132	36.80	3242	34.8	3243	34.6	3363	34.8	3473	34	3583
		0.83	2055	1.25	3199	1.67	3957	2.99	7045	5.92	14029	9.83	22759
22	40	39.1	3132			39.5	3243	38.3	3363	39.9	3473	38.6	3583
		0.75	2039			1.47	3954	2.71	7068	5.19	14101	8.68	22815
19	45	44.8	3132			45.2	3243	43.7	3363	44.1	3473	42.6	3583
		0.5	1558			1.29	3971	2.38	7082	4.71	14144	7.88	22859
17	50	49.4	3132			51	3243	50.3	3363	50.6	3473	49.8	3583
		0.5	1718			1.14	3959	2.07	7090	4.11	14162	6.77	22958
16	56					54.1	3243	53.8	3363	57	3473	55.5	3583
						1.08	3979	1.94	7107	3.66	14206	6.08	22978
14	63					64.3	3243	61	3363	61.9	3473	62.4	3583
						0.91	3984	1.72	7145	3.37	14205	5.42	23031
12	71					68	3243	67.8	3363	69	3473	70.6	3583
						0.86	3982	1.55	7156	3.03	14237	4.81	23124
11	80					77.7	3243	77	3363	77.5	3473	80.6	3583
						0.75	3968	1.36	7131	2.7	14249	4.22	23162
10	90					86.7	3243	85.7	3363	87.7	3473	86.5	3583
						0.68	4015	1.23	7178	2.39	14273	3.94	23208
9	100					97.2	3243	96.4	3363	95.4	3473	101	3583
						0.6	3971	1.09	7155	2.2	14292	3.38	23247
8	112					113	3243	113	3363	108	3473	109	3583
						0.52	4001	0.93	7156	1.95	14341	3.14	23307
7	125					124	3243	125	3363	124	3473	121	3583
						0.48	4053	0.84	7150	1.7	14355	2.83	23318
6.2	140					142	3243	137	3363	139	3473	135	3583
						0.42	4061	0.77	7183	1.52	14387	2.56	23360
5.4	160					156	3243	160	3363	154	3473	159	3583
						0.38	4037	0.66	7191	1.37	14367	2.16	23387

Note: If shaded, Mechanical HP shown may exceed thermal HP limit. Refer to Page B-143-144

R.O. Refer application details to Marketing

Exact ratio	<b>Gear Frame</b>
Input H.P.	Output Torque



# Specifications

OtN  
SERIES 3000

## Combined - Motor rpm 1750

OtN Series

Gear Frame															
Nom. RPM	Nom. Ratio	32		33		34		35		36		37		38	
16	112														
14	125														
12.5	140														
10.9	160														
9.7	180	178 0.686	3245 3960	174 1.252	3365 7060	172 2.523	3475 14065	174 4.051	3585 22845	180 6.817	3695 39775	187 12.067	3705 73140		
8.8	200	197 0.620	3245 3960	196 1.111	3365 7060	194 2.237	3475 14065	184 3.831	3585 22845	191 6.425	3695 39775	216 10.447	3705 73140		
7.8	224	207 0.590	3245 3960	222 0.981	3365 7060	220 1.972	3475 14065	208 3.389	3585 22845	225 5.454	3695 39775	230 9.811	3705 73140		
7.0	250	246 0.497	3245 3960	252 0.864	3365 7060	250 1.736	3475 14065	235 2.999	3585 22845	240 5.113	3695 39775	261 8.646	3705 73140		
6.3	280	263 0.465	3245 3960	288 0.756	3365 7060	286 1.517	3475 14065	265 2.660	3585 22845	272 4.512	3695 39775	290 7.781	3705 73140		
5.6	315	295 0.414	3245 3960	325 0.670	3365 7060	322 1.348	3475 14065	302 2.334	3585 22845	300 4.090	3695 39775	330 6.838	3705 73140		
4.9	355	343 0.356	3245 3960	345 0.631	3365 7060	342 1.286	3475 14259	345 2.043	3585 22845	341 3.599	3695 39775	367 6.149	3705 73140	337.3 10.28	3825 112861
4.4	400	370 0.330	3245 3960	410 0.531	3365 7060	386 1.140	3475 14259	389 1.812	3585 22845	395 3.107	3695 39775	425 5.309	3705 73140	398.7 9.2	3825 119450
3.9	450	435 0.281	3245 3960	434 0.502	3365 7060	437 1.007	3475 14259	413 1.707	3585 22845	422 2.908	3695 39775	455 4.959	3705 73140	425.2 8.63	3825 119450
3.5	500	488 0.250	3245 3960	496 0.439	3365 7060	482 0.914	3475 14286	490 1.438	3585 22845	479 2.562	3695 39775	516 4.373	3705 73140	480.9 7.63	3825 119450
3.1	560	549 0.223	3245 3960	553 0.394	3365 7060	548 0.804	3475 14286	518 1.361	3585 22845	532 2.307	3695 39775	573 3.938	3705 73140	532.2 6.89	3825 119450
2.8	630	617 0.198	3245 3960	620 0.351	3365 7060	626 0.704	3475 14286	592 1.191	3585 22845	605 2.028	3695 39775	651 3.466	3705 73140	606.4 6.05	3825 119450
2.5	710	718 0.173	3245 4032	734 0.303	3365 7215	707 0.623	3475 14286	661 1.066	3585 22845	673 1.823	3695 39775	724 3.117	3705 73140	688.2 5.33	3825 119450
2.2	800	793 0.157	3245 4032	829 0.269	3365 7215	750 0.588	3475 14286	741 0.951	3585 22845	757 1.621	3695 39775	815 2.769	3705 73140	793.2 4.63	3825 119450
1.9	900	835 0.149	3245 4032	937 0.238	3365 7215	891 0.495	3475 14286	866 0.835	3585 23447	887 1.383	3695 39775	955 2.363	3705 73140	847.6 4.33	3825 119450
1.8	1000	991 0.126	3245 4032	1010 0.221	3365 7246	942 0.468	3475 14286	976 0.741	3585 23447	979 1.253	3695 39775	1054 2.141	3705 73140	962.0 3.81	3825 119450
1.6	1120	1062 0.117	3245 4032	1116 0.200	3365 7246	1185 0.376	3475 14436	1105 0.655	3585 23447	1074 1.143	3695 39775	1156 1.952	3705 73140	1068.5 3.43	3825 119450
1.4	1250	1189 0.105	3245 4032	1175 0.190	3365 7246	1355 0.329	3475 14436	1255 0.576	3585 23447	1254 0.979	3695 39775	1298 1.792	3705 75388	1213.7 3.02	3825 119450
1.3	1400	1384 0.090	3245 4032	1394 0.160	3365 7246	1529 0.291	3475 14436	1319 0.550	3585 23500	1504 0.836	3695 40747	1467 1.585	3705 75388	1350.4 2.72	3825 119450
1.1	1600	1493 0.083	3245 4032	1494 0.150	3365 7246	1622 0.275	3475 14436	1499 0.484	3585 23500	1607 0.782	3695 40747	1624 1.432	3705 75388	1519.2 2.42	3825 119450
0.97	1800	1756 0.071	3245 4032	1673 0.134	3365 7246	1926 0.231	3475 14436	1713 0.423	3585 23500	1823 0.690	3695 40747	1851 1.257	3705 75388	1780.8 2.06	3825 119450
0.88	2000	1968 0.063	3245 4032	1947 0.115	3365 7246	2037 0.219	3475 14436	1933 0.375	3585 23500	2025 0.621	3695 40747	2134 1.090	3705 75388	1965.7 1.87	3825 119450
0.78	2240	2213 0.056	3245 4032	2100 0.106	3365 7246	2329 0.191	3475 14436	2051 0.353	3585 23500	2301 0.546	3695 40747	2280 1.020	3705 75388	2155.5 1.7	3825 119450

Exact ratio	Gear Frame
Input H.P.	Output Torque



## Combined - Motor rpm 1750 (Continued)

OtN Series

Gear Frame															
Nom. RPM	Nom. Ratio	32		33		34		35		36		37		38	
0.70	2500	2488	3245	2470	3365	2599	3475	2436	3585	2560	3695	2588	3705	2517.0	3825
		0.050	4032	0.091	7246	0.171	14436	0.298	23500	0.491	40747	0.899	75388	1.46	119450
0.63	2800	2804	3245	2768	3365	2914	3475	2576	3585	2880	3695	2874	3705	2751.8	3825
		0.044	4032	0.081	7246	0.153	14436	0.281	23500	0.437	40747	0.809	75388	1.33	119450
0.56	3150	3158	3245	3113	3365	3374	3475	2944	3585	2946	3696	3265	3705	3225.5	3825
		0.039	4032	0.072	7246	0.132	14436	0.246	23500	0.427	40747	0.712	75388	1.14	119450
0.49	3550	3474	3245	3500	3365	3705	3475	3286	3585	3480	3696	3632	3705	3560.5	3825
		0.036	4032	0.064	7246	0.120	14436	0.221	23500	0.361	40747	0.640	75388	1.03	119450
0.44	4000	3920	3245	3945	3365	4248	3475	3685	3585	4196	3696	4086	3705	3904.2	3825
		0.032	4032	0.057	7246	0.105	14436	0.197	23500	0.300	40747	0.569	75388	0.94	119450
0.39	4500	4410	3245	4443	3365	4437	3476	4266	3585	4645	3696	4790	3705	4559.1	3825
		0.028	4032	0.050	7246	0.103	14419	0.170	23500	0.271	40747	0.486	75388	0.8	119450
0.35	5000	4779	3246	4887	3365	5071	3476	4684	3585	5295	3696	5268	3706	5059.4	3826
		0.027	4032	0.046	7246	0.090	14419	0.155	23500	0.237	40747	0.442	75388	0.74	119450
0.31	5600	5350	3246	5515	3365	5721	3476	5371	3585	6103	3696	5954	3706	5831.8	3826
		0.024	4032	0.041	7246	0.080	14419	0.135	23500	0.206	40747	0.391	75388	0.64	119450
0.28	6300	6229	3246	6204	3365	6071	3476	6625	3586	6521	3696	6592	3706	6231.7	3826
		0.020	4032	0.036	7246	0.075	14419	0.111	23385	0.193	40747	0.353	75388	0.6	119450
0.25	7100	6717	3246	7014	3366	7210	3476	7008	3586	7401	3696	7513	3706	7072.4	3826
		0.019	4032	0.032	7207	0.063	14419	0.105	23385	0.170	40747	0.310	75388	0.53	119450
0.22	8000	7902	3246	7888	3366	7626	3476	8009	3586	8220	3696	8660	3706	7855.1	3826
		0.016	4032	0.029	7207	0.060	14419	0.092	23385	0.153	40747	0.269	75388	0.48	119450
0.19	9000	8854	3246	8868	3366	8715	3476	8938	3586	9338	3696	9254	3706	8923.1	3826
		0.014	4032	0.026	7207	0.052	14419	0.083	23385	0.135	40747	0.251	75388	0.42	119450
0.18	10000	9958	3246	9997	3366	9727	3476	10023	3586	10389	3696	10502	3706	9928.0	3826
		0.013	4032	0.023	7207	0.047	14419	0.074	23385	0.121	40747	0.221	75388	0.38	119450

Exact ratio	Gear Frame
Input H.P.	Output Torque

Thermal Power Rating (Pt)

Mounting Position(s): B  
Ambient Temperature: 40C  
Cooling Method: Convection

OtN Series

Nominal Ratio	Reducer Size			
	35	36	37	38
	Pt (hp)	Pt (hp)	Pt (hp)	Pt (hp)
10	27	46	66	**
11.2	N/A	44	61	**
12.5	27	44	59	**
14	27	44	51	**
16	27	44	51	**
18	27	43	49	**
20	27	43	49	**
22.4	27	43	49	59
25	-	43	-	59
28	-	-	-	59
31.5	-	-	-	59
35.5	-	-	-	59
40	-	-	-	59
45	-	-	-	-
50	-	-	-	-

Examples of "B" Mounting Positions

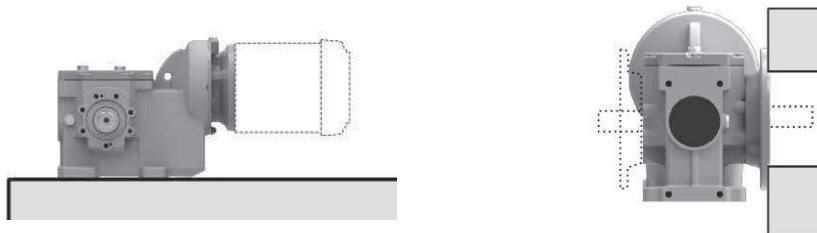

<sup>1</sup> For operation greater than 3 hours per day and when an AP reducer design is utilized, refer to office for evaluation of a reducer equipped with a fan and guard supplied on the high speed input shaft.

\*\* Reducers must be used with external cooling supplied by others when with these ratios, gear mounting positions(s) noted and for operation exceeding 3 hours per day.



## Thermal Power Rating (Pt)

Mounting Position(s): P, H, T, V, W

Ambient Temperature: 40C

Cooling Method: Convection

OtN Series

Nominal Ratio	Reducer Size			
	35	36	37	38
	Pt (hp)	Pt (hp)	Pt (hp)	Pt (hp)
10	22	**	**	**
11.2		**	**	**
12.5	22	**	**	**
14	22	**	41	**
16	22	36	41	**
18	22	34	41	**
20	22	34	41	**
22.4	22	34	41	**
25		34	-	**
28		-	-	49
31.5		-	-	49
35.5		-	-	49
40		-	-	49
45		-	-	49
50		-	-	-

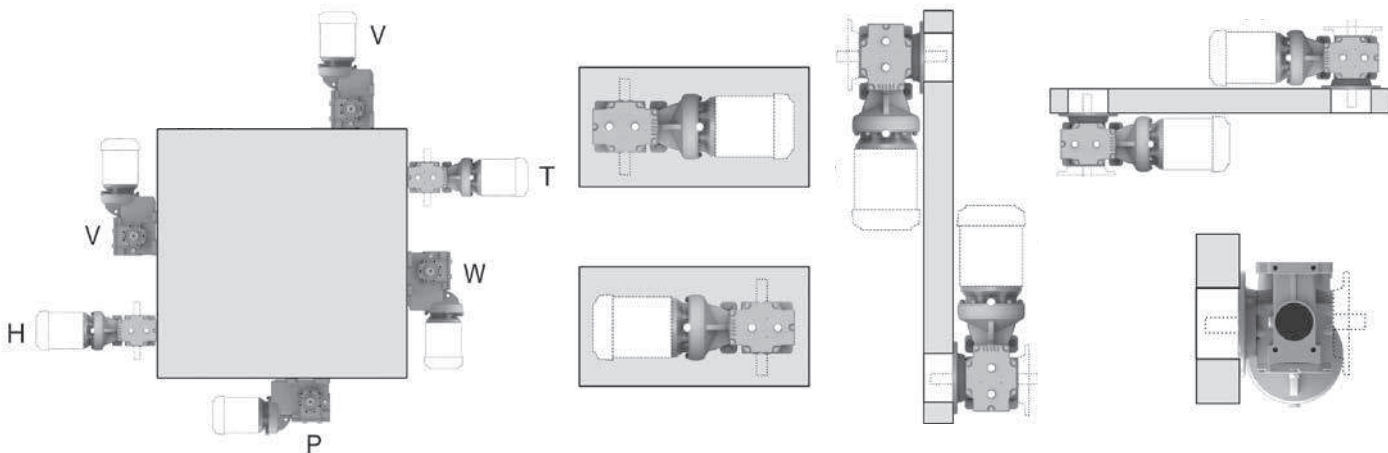

<sup>1</sup> For operation greater than 3 hours per day and when an AP reducer design is utilized, refer to office for evaluation of a reducer equipped with a fan and guard supplied on the high speed input shaft.

\*\* Reducers must be used with external cooling supplied by others when with these ratios, gear mounting positions(s) noted and for operation exceeding 3 hours per day.

## 2-Stage Output Shafted Foot Mount OtN31 - 32

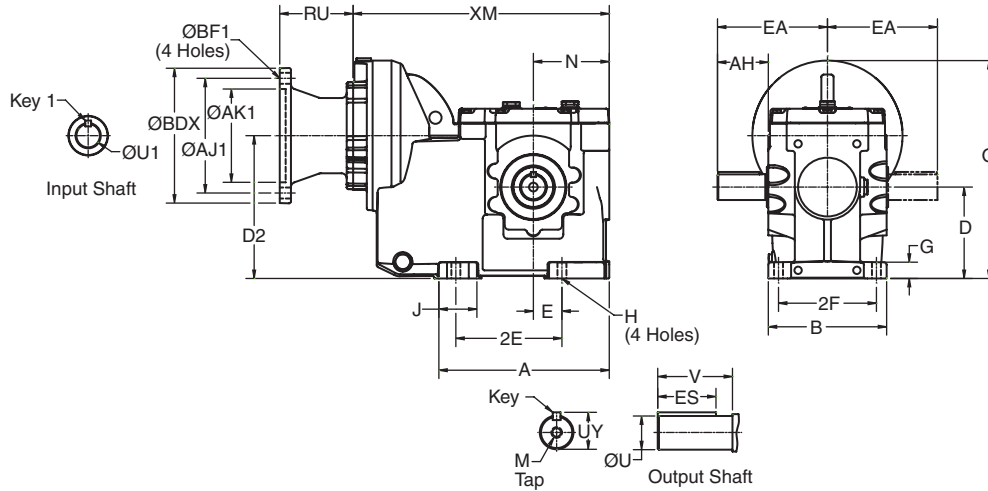

OtN Series

Gear Frame	Version	A	B	D <sup>1</sup>	D2	E	2E	2F	G	H	J	O	N	XM
3132	S2	5.88	4.65	3.15	4.98	1.97	3.94	3.94	.56	.35	1.53	8.01	3.15	10.59
3242	S2	8.22	5.71	4.41	6.89	1.38	5.12	4.72	.79	.43	1.83	10.51	3.66	12.36

### Output Shaft

Gear Frame	Version	U <sup>3</sup>	UY	V	AH	EA	Key	ES	M
3132	S2	1.000	1.10	1.77	1.83	4.33	1/4 Sq.	1.34	3/8-16 X .87
3242	S2	1.250	1.35	2.38	2.45	5.31	1/4 Sq.	2.03	1/2-13 X 1.12

Motor Frame	Gear Frame	AJ1	AK1	BF1	U1	RU	BDX	Key1
56C	Any	5.88	4.50	.38	.625	3.54	6.50	3/16 Sq.
143TC/145TC	Any	5.88	4.50	.38	.875	3.54	6.50	3/16 Sq.
182TC/184TC	32	7.25	8.50	.50	1.125	5.26	9.00	1/4 Sq.

<sup>1</sup> Dimension "D" will never be exceeded, but may vary from values shown. When exact dimensions are required, shims up to .03" may be necessary.

<sup>2</sup> All rough casting dimensions may vary by .25" due to casting variations.  
<sup>3</sup> Output shaft extension tolerances: +.0000"; -.0005" for shafts up to 1.5" diameter "U". Larger diameter "U", +.000"; -.001".

## 3-Stage Output Shafted Foot Mount OtN32 - 35

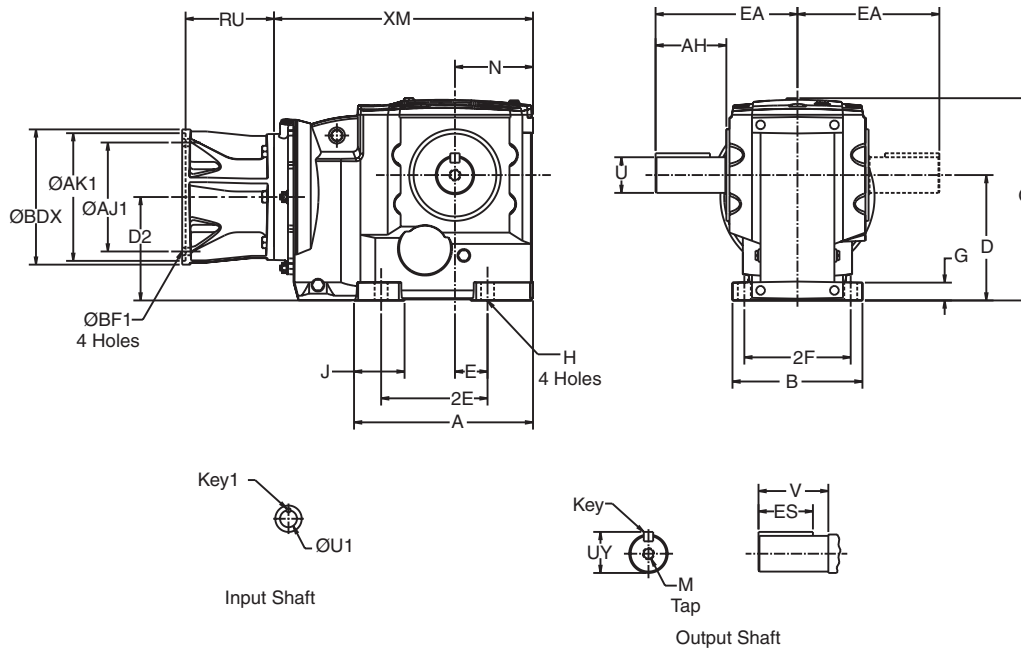

Gear Frame	Version	A	B	D <sup>1</sup>	D2	E	2E	2F	G	H	J	O	N	XM	
														56C-215TC	254TC-286TC
32	S2	7.81	5.71	4.41	3.78	1.38	5.12	4.72	.73	.43	2.34	8.09	3.03	10.98	-
33	S2	8.50	6.61	5.51	5.24	1.18	4.72	5.51	.85	.55	2.86	9.69	3.54	12.90	-
	S1	8.08	8.58	4.92	5.20	3.35	6.69	6.10	.79	.55	2.27	10.43	3.54		
34	S2	10.13	7.87	7.09	5.90	1.57	5.91	6.50	1.07	.71	2.67	12.05	4.49	14.56	-
	S1	10.69	9.60	6.30	7.49	4.53	9.06	7.68	1.18	.71	3.19	13.39	4.49		
35	S2	11.92	8.66	8.35	6.89	2.17	7.09	7.09	1.18	.87	3.37	13.58	5.20	16.90	17.25
	S1	13.07	10.98	7.87	9.33	5.51	11.02	9.06	1.40	.87	4.05	16.22	5.20		

### Output Shaft

Gear Frame	Version	U <sup>3</sup>	UY	V	AH	EA	Key	ES	M
32	S2	1.250	1.354	2.36	2.46	5.31	1/4 Sq.	2.06	1/2-13 X 1.12
33	S2	1.625	1.783	3.25	3.39	6.73	3/8 Sq.	2.78	5/8-11 X 1.38
	S1	1.500	1.657	3.18	3.19	7.12	3/8 Sq.	2.78	5/8-11 X 1.38
34	S2	2.000	2.210	3.63	3.76	8.11	1/2 Sq.	3.06	3/4-10 X 1.61
	S1	1.750	1.909	3.56	3.66	8.46	3/8 Sq.	3.56	3/4-10 X 1.61
35	S2	2.375	2.638	4.61	4.74	9.45	5/8 Sq.	3.81	3/4-10 X 1.61
	S1	2.375	2.638	5.73	5.27	10.57	5/8 Sq.	4.81	3/4-10 X 1.61

### C-Face Input

Motor Frame	Gear Frame	AJ1	AK1	BF1	U1	RU	BDX	Key1
56C	Any	5.88	4.50	.38	.625	3.54	6.50	3/16 Sq.
143TC/145TC	Any	5.88	4.50	.38	.875	3.54	6.50	3/16 Sq.
182TC/184TC	Any	7.25	8.50	.50	1.125	5.26	9.00	1/4 Sq.
213TC/215TC	33,34,35	7.25	8.50	.50	1.375	5.26	9.00	5/16 Sq.
254TC/256TC	35	7.25	8.50	.50	1.625	6.12	9.00	3/8 Sq.
284TC/286TC	35	9.00	10.50	.50	1.875	7.09	11.25	1/2 Sq.

<sup>1</sup> Dimension "D" will never be exceeded, but may vary from values shown. When exact dimensions are required, shims up to .03" may be necessary. <sup>2</sup> All rough casting dimensions may vary by .25" due to casting variations. <sup>3</sup> Output shaft extension tolerances: +.0000"; -.0005" for shafts up to 1.5" diameter "U". Larger diameter "U", +.000"; -.001".

## 3-Stage Output Shafted Foot Mount OtN36 - 38

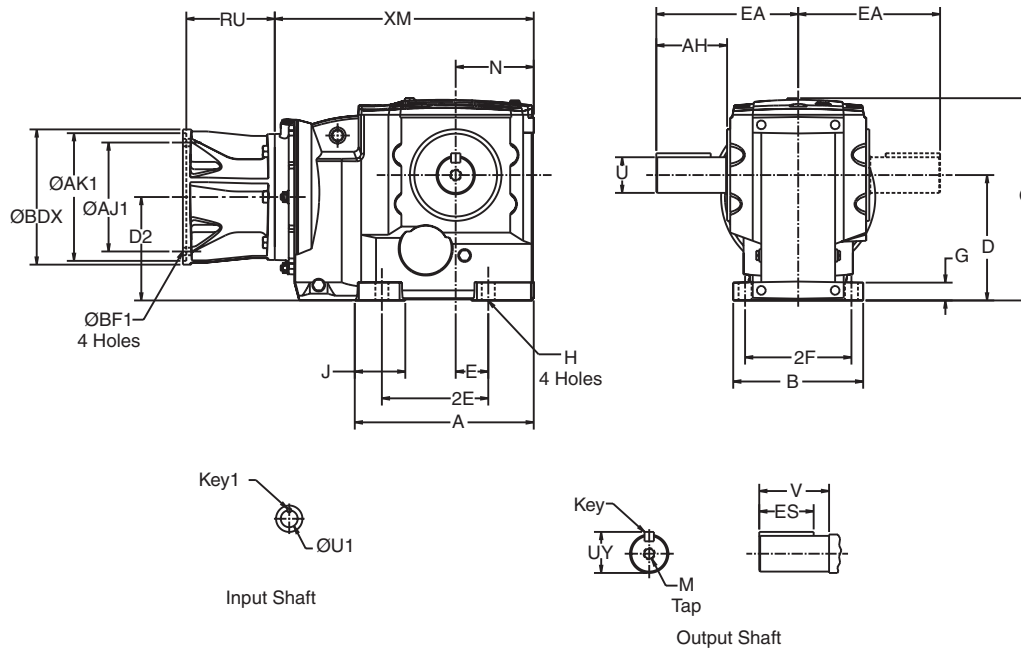

OtN Series

Gear Frame	Version	A	B	D <sup>1</sup>	D2	E	2E	2F	G	H	J	O	N	XM	
														182-215TC	254-365TC
36	S1	17.06	11.41	8.86	8.86	6.99	13.98	9.45	1.57	.87	3.87	16.26	8.74	23.38	23.73
37	S1	20.58	12.99	9.84	10.98	8.27	16.54	10.63	1.93	.94	4.78	18.29	10.04	23.38	29.06
38	S2	17.85	13.39	14.76	11.87	4.53	13.78	10.63	1.98	1.26	4.06	24.11	8.86	24.29	24.64

### Output Shaft

Gear Frame	Version	U <sup>3</sup>	UY	V	AH	EA	Key	ES	M
36	S1	2.875	3.20	5.75	5.92	11.94	3/4 SQ.	5.00	3/4-10 X 1.61
37	S1	3.625	4.01	6.86	7.04	13.66	7/8 SQ.	6.00	1-8 X 2.13
38	S2	4.375	4.809	8.99	9.97	17.03	1.00 SQ.	7.00	1-8 X 2.25

Motor Frame	Gear Frame	AJ1	AK1	BF1	U1	RU	BDX	Key1
182TC/184TC	36,37	7.25	8.50	.50	1.125	5.26	9.00	1/4 Sq.
213TC/215TC	All	7.25	8.50	.50	1.375	5.26	9.00	5/16 Sq.
254TC/256TC	All	7.25	8.50	.50	1.625	6.12	9.00	3/8 Sq.
284TC/286TC	All	9.00	10.50	.50	1.875	7.09	11.25	1/2 Sq.
324TC/326TC	All	11.00	12.50	.625	2.125 <sup>4</sup>	8.45	13.38	1/2 Sq.
364TC/365TC	All	11.00	12.50	.625	2.375 <sup>4</sup>	8.45	13.38	5/8 Sq.

<sup>1</sup> Dimension "D" will never be exceeded, but may vary from values shown. When exact dimensions are required, shims up to .03" may be necessary.

<sup>2</sup> All rough casting dimensions may vary by .25" due to casting variations.

<sup>3</sup> Output shaft extension tolerances: +.0000"; -.0005" for shafts up to 1.5" diameter "U". Larger diameter "U", +.000"; -.001".

<sup>4</sup> These frames utilize a coupling. This is the bore of the coupling for the motor shaft.

## Combined Output Shafted Foot Mount OtN32 - 35

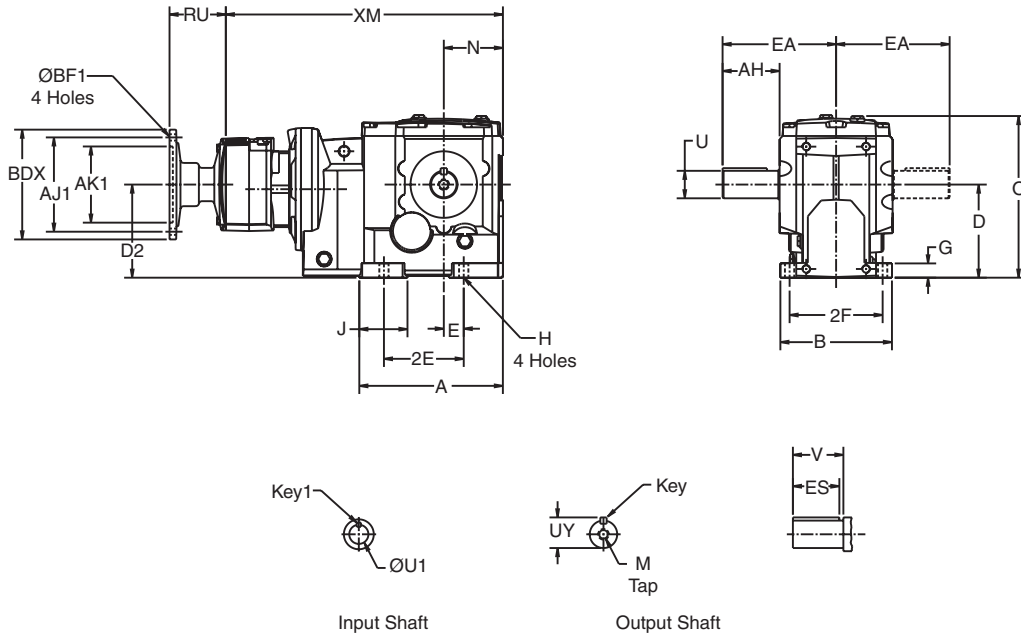

Gear Frame	Version	A	B	D <sup>1</sup>	D2	E	2E	2F	G	H	J	O	N	XM
32	S2	7.81	5.71	4.41	4.06	1.38	5.12	4.72	.73	.43	2.34	8.09	3.03	14.49
33,33A	S2	8.50	6.61	5.51	4.91	1.18	4.72	5.51	.85	.55	2.86	9.69	3.54	19.90 <sup>4</sup>
	S1	8.08	8.58	4.92	4.87	3.35	6.69	6.10	.79	.55	2.27	10.43	3.54	
34	S2	10.13	7.87	7.09	5.57	1.57	5.91	6.50	1.07	.71	2.67	12.05	4.49	21.55
	S1	10.69	9.60	6.30	7.16	4.53	9.06	7.68	1.18	.71	3.19	13.39	4.49	
35	S2	11.92	8.66	8.35	6.56	2.17	7.09	7.09	1.18	.87	3.37	13.58	5.20	23.87
	S1	13.07	10.98	7.87	9.00	5.51	11.02	9.06	1.40	.87	4.05	16.22	5.20	

### Output Shaft

Gear Frame	Version	U <sup>3</sup>	UY	V	AH	EA	Key	ES	M
32	S2	1.250	1.354	2.36	2.46	5.31	1/4 Sq.	2.06	1/2-13 X 1.12
33,33A	S2	1.625	1.783	3.25	3.39	6.73	3/8 Sq.	2.78	5/8-11 X 1.38
	S1	1.500	1.657	3.18	3.19	7.12	3/8 Sq.	2.78	5/8-11 X 1.38
34	S2	2.000	2.210	3.63	3.76	8.11	1/2 Sq.	3.06	3/4-10 X 1.61
	S1	1.750	1.909	3.56	3.66	8.46	3/8 Sq.	3.56	3/4-10 X 1.61
35	S2	2.375	2.638	4.61	4.74	9.45	5/8 Sq.	3.81	3/4-10 X 1.61
	S1	2.375	2.638	5.73	5.27	10.57	5/8 Sq.	4.81	3/4-10 X 1.61

### C-Face Input

Motor Frame	Gear Frame	AJ1	AK1	BF1	U1	RU	BDX	Key1
56C	32,33A	5.88	4.50	.38	.625	3.33	6.50	3/16 Sq.
	33,34,35	5.88	4.50	.38	.625	3.54	6.50	3/16 Sq.
143TC/145TC	32,33A	5.88	4.50	.38	.875	3.33	6.50	3/16 Sq.
	33,34,35	5.88	4.50	.38	.875	3.54	6.50	3/16 Sq.
182TC/184TC	33,34,35	7.25	8.50	.50	1.125	5.26	9.00	1/4 Sq.

<sup>1</sup> Dimension "D" will never be exceeded, but may vary from values shown. When exact dimensions are required, shims up to .03" may be necessary.

<sup>2</sup> All rough casting dimensions may vary by .25" due to casting variations.

<sup>3</sup> Output shaft extension tolerances: +.0000"; -.0005" for shafts up to 1.5" diameter "U". Larger diameter "U", +.000"; -.001".

<sup>4</sup> XM dimension when gear frame 33A is used will be 16.42.

## Combined Output Shafted Foot Mount OtN36 - 38

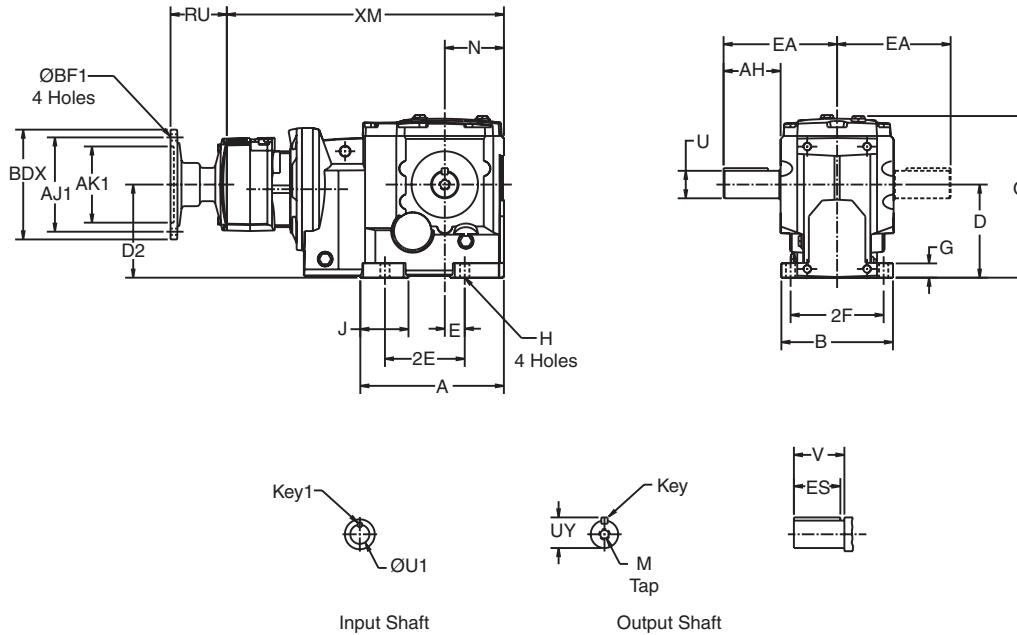

OtN Series

Gear Frame	Version	A	B	D <sup>1</sup>	D2	E	2E	2F	G	H	J	O	N	XM
														56-215TC
36	S1	17.06	11.41	8.86	8.46	6.99	13.98	9.45	1.57	.87	3.87	16.26	8.74	31.04
37	S1	20.58	12.99	9.84	10.57	8.27	16.54	10.63	1.93	.94	4.78	18.29	10.04	36.37
38	S2	17.85	13.39	14.76	11.48	4.53	13.78	10.63	1.98	1.26	4.06	24.11	8.86	31.94

### Output Shaft

Gear Frame	Version	U <sup>3</sup>	UY	V	AH	EA	Key	ES	M
36	S1	2.875	3.20	5.75	5.92	11.94	3/4 SQ.	5.00	3/4-10 X 1.61
37	S1	3.625	4.01	6.86	7.04	13.66	7/8 SQ.	6.00	1-8 X 2.13
38	S2	4.375	4.809	8.99	9.97	17.03	1.00 SQ.	7.00	1-8 X 2.25

Motor Frame	Gear Frame	AJ1	AK1	BF1	U1	RU	BDX	Key1
56C	All	5.88	4.50	.38	.625	3.54	6.50	3/16 Sq.
143TC/145TC	All	5.88	4.50	.38	.875	3.54	6.50	3/16 Sq.
182TC/184TC	All	7.25	8.50	.50	1.125	5.26	9.00	1/4 Sq.
213TC/215TC	All	7.25	8.50	.50	1.375	5.26	9.00	5/16 Sq.

<sup>1</sup> Dimension "D" will never be exceeded, but may vary from values shown. When exact dimensions are required, shims up to .03" may be necessary. <sup>2</sup> All rough casting dimensions may vary by .25" due to casting variations. <sup>3</sup> Output shaft extension tolerances: +.0000"; -.0005" for shafts up to 1.5" diameter "U". Larger diameter "U", +.000"; -.001".

## 2-Stage Output Shafted Flange Mount OtN31 - 32

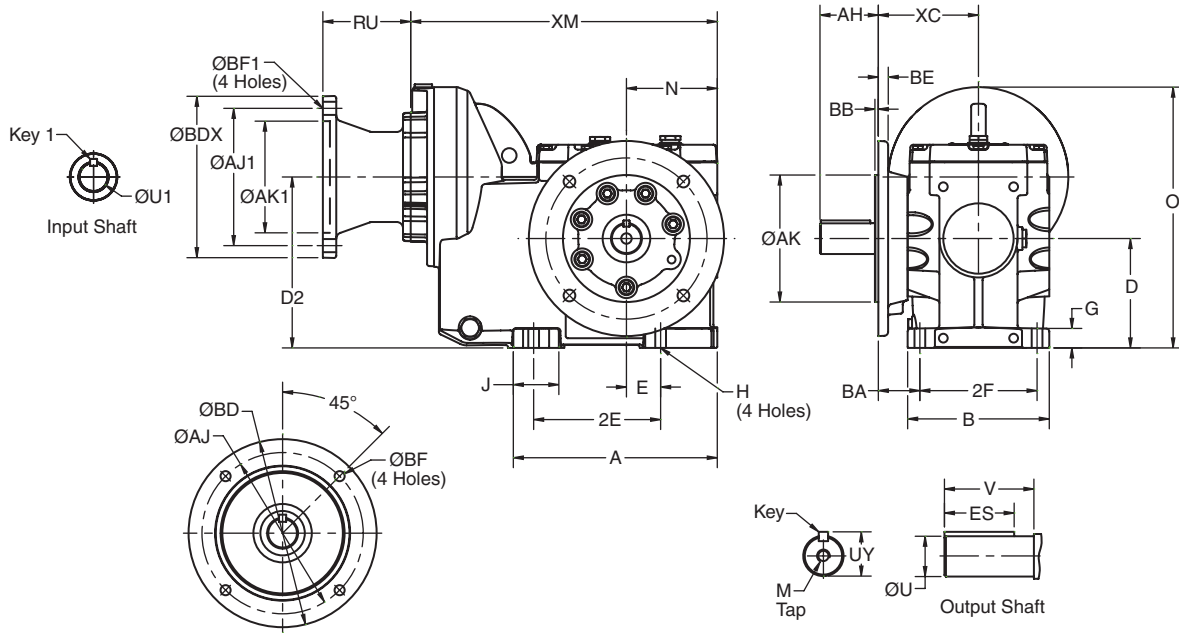

OtN Series

Gear Frame	Version	A	B	D <sup>1</sup>	D2	E	2E	2F	G	H	J	O	N	BA	XC	XM
3132	S2	5.88	4.65	3.15	4.98	1.97	3.94	3.94	.56	.35	1.53	8.01	3.15	1.54	3.50	10.59
3242	S2	8.22	5.71	4.41	6.89	1.38	5.12	4.72	.79	.43	1.83	10.51	3.66	1.67	4.04	12.36

### Output Shaft

Gear Frame	Version	U <sup>3</sup>	UY	V	AH	Key	ES	M
3132	S2	1.000	1.10	1.97	1.97	1/4 Sq.	1.34	3/8-16 X .87
3242	S2	1.250	1.35	2.36	2.35	1/4 Sq.	2.03	1/2-13 X 1.13

### Output Flange

Gear Frame	Flange Code	AK	AJ	BB	BD	BE	BF
3132	5	4.331	5.12	.14	6.50	.39	.35
3132	6	3.740	4.53	.14	5.51	.44	.35
3242	5	5.118	6.50	.14	7.87	.39	.47
3242	6	7.087	8.46	.16	9.84	.47	.55

Motor Frame	Gear Frame	AJ1	AK1	BF1	U1	RU	BDX	Key1
56C	Any	5.88	4.50	.38	.625	3.54	6.50	3/16 Sq.
143TC/145TC	Any	5.88	4.50	.38	.875	3.54	6.50	3/16 Sq.
182TC/184TC	32	7.25	8.50	.50	1.125	5.26	9.00	1/4 Sq.

<sup>1</sup> Dimension "D" will never be exceeded, but may vary from values shown. When exact dimensions are required, shims up to .03" may be necessary.

<sup>2</sup> All rough casting dimensions may vary by .25" due to casting variations.

<sup>3</sup> Output shaft extension tolerances: +.0000"; -.0005" for shafts up to 1.5" diameter "U". Larger diameter "U", +.000"; -.001".



## 3-Stage Output Shafted Flange Mount OtN32 - 35

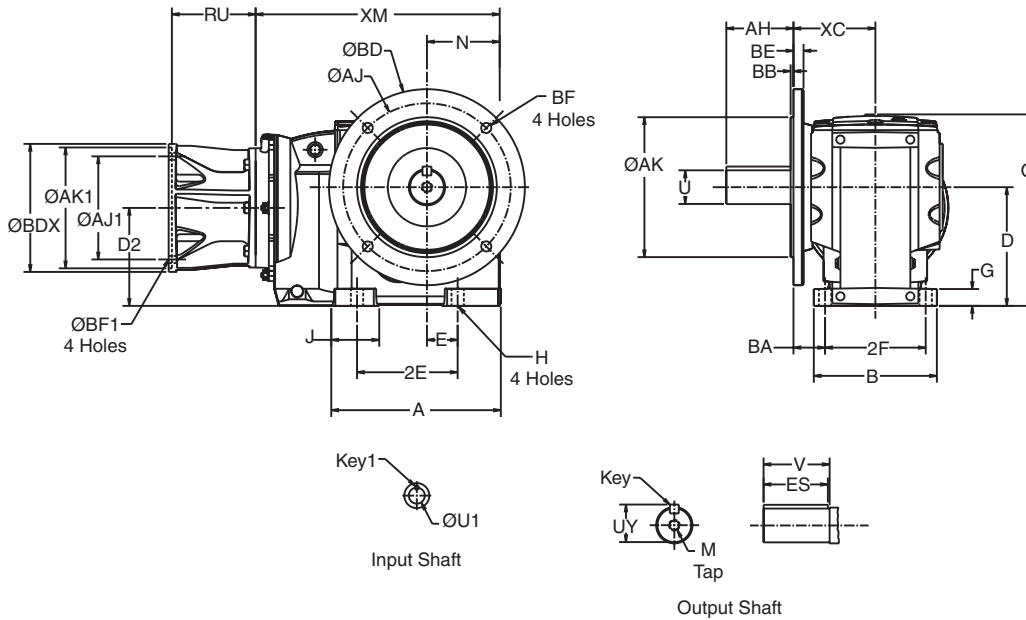

OtN Series

Gear Frame	Version	A	B	D <sup>1</sup>	D2	E	2E	2F	G	H	J	O	N	BA	XC	XM	
																56C-215TC	254TC-286TC
32	S1,S2	7.81	5.71	4.41	3.78	1.38	5.12	4.71	.73	.43	2.34	8.09	3.03	1.81	4.04	10.98	-
33	S1,S2	8.50	6.61	5.51	5.24	1.18	4.72	5.51	.85	.55	2.86	9.69	3.54	2.24	4.84	12.90	-
34	S1,S2	10.13	7.87	7.09	5.90	1.57	5.91	6.50	1.07	.71	2.67	12.05	4.49	1.93	5.18	14.56	-
35	S2	11.92	8.66	8.35	6.89	2.17	7.09	7.09	1.18	.87	3.45	13.58	5.20	2.22	5.76	16.90	17.25

### Output Shaft

Gear Frame	Version	U <sup>3</sup>	UY	V	AH	Key	ES	M
32	S2	1.250	1.354	2.38	2.36	1/4 Sq.	2.06	1/2-13 X 1.12
	S1	1.250	1.354	1.77	1.75	1/4 Sq.	1.45	1/2-13 X 1.12
33	S2	1.625	1.783	3.25	3.15	3/8 Sq.	2.78	5/8-11 X 1.38
	S1	1.500	1.657	3.18	2.28	3/8 Sq.	2.19	5/8-11 X 1.38
34	S2	2.000	2.210	3.94	3.94	1/2 Sq.	3.06	3/4-10 X 1.61
	S1	1.750	1.909	3.56	3.28	3/8 Sq.	3.56	3/4-10 X 1.61
35	S2	2.375	2.638	4.72	4.72	5/8 Sq.	3.81	3/4-10 X 1.61

### Output Flange

Gear Frame	Flange Code	AK	AJ	BB	BD	BE	BF
32	5	5.118	6.50	.14	7.87	.39	.47
	6	7.087	8.46	.16	9.84	.47	.55
33	5	7.087	8.46	.16	9.84	.47	.55
	6	9.055	10.43	.16	11.81	.47	.55
34	5	9.055	10.43	.16	11.81	.59	.55
	6	9.842	11.80	.16	13.77	.59	.71
35	5	9.842	11.80	.20	13.77	.71	.71
	6	11.810	13.77	.20	15.75	.71	.71

### C-Face Input

Motor Frame	Gear Frame	AJ1	AK1	BF1	U1	RU	BDX	Key1
56C	Any	5.88	4.50	.38	.625	3.54	6.50	3/16 Sq.
143TC/145TC	Any	5.88	4.50	.38	.875	3.54	6.50	3/16 Sq.
182TC/184TC	Any	7.25	8.50	.50	1.125	5.26	9.00	1/4 Sq.
213TC/215TC	33,34,35	7.25	8.50	.50	1.375	5.26	9.00	5/16 Sq.
254TC/256TC	35	7.25	8.50	.50	1.625	6.12	9.00	3/8 Sq.
284TC/286TC	35	9.00	10.50	.50	1.875	7.09	11.25	1/2 Sq.

<sup>1</sup> Dimension "D" will never be exceeded, but may vary from values shown. When exact dimensions are required, shims up to .03" may be necessary. <sup>2</sup> All rough casting dimensions may vary by .25" due to casting variations. <sup>3</sup> Output shaft extension tolerances: +.0000"; -.0005" for shafts up to 1.5" diameter "U". Larger diameter "U", +.000"; -.001".

**3-Stage Output Shafted Flange Mount**  
**OtN36 - 38**

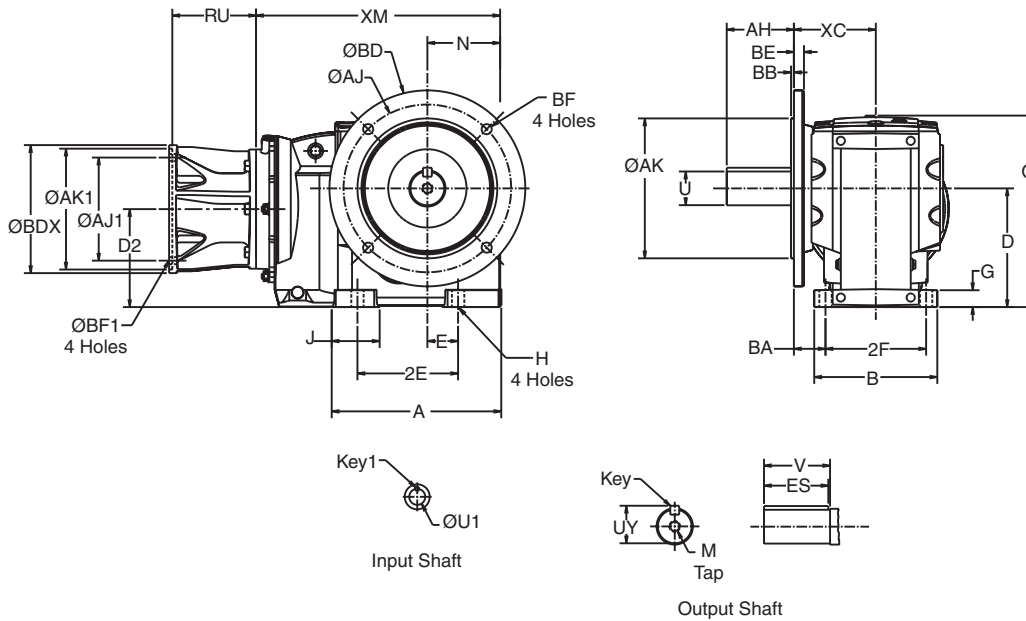

**OtN Series**

Gear Frame	Version	A	B	D <sup>1</sup>	D2	E	2E	2F	G	H	J	O	N	BA	XC	XM	
																182-215TC	254-365TC
36	S2	17.06	11.41	8.86	8.86	6.99	13.98	9.45	1.57	.87	3.87	16.26	8.74	4.45	9.17	23.38	23.73
37	S2	20.58	12.99	9.84	10.98	8.27	16.54	10.63	1.93	.94	4.78	18.29	10.04	4.45	9.76	23.38	29.06
38	S2	17.85	13.39	14.76	11.87	4.53	13.78	10.63	1.98	1.26	4.06	24.11	8.86	4.65	9.96	24.29	24.64

**Output Shaft**

Gear Frame	Version	U <sup>3</sup>	UY	V	AH	Key	ES	M
36	S2	2.875	3.20	7.68	5.51	3/4 SQ.	5.00	3/4-10 X 1.61
37	S2	3.625	4.01	8.88	6.69	7/8 SQ.	6.00	1-8 X 2.13
38	S2	4.375	4.809	8.99	9.97	1.00 SQ.	7.00	1-8 X 2.25

**Output Flange**

Gear Frame	Flange Code	AK	AJ	BB	BD	BE	BF
36 & 37	5	13.78	15.75	.236	17.70	.79	.71
	6	17.72	19.68	.236	21.65	.63	.87
38	5	17.72	19.69	.200	21.65	.79	.69
	6	21.65	23.62	.236	25.98	.63	.87

Motor Frame	Gear Frame	AJ1	AK1	BF1	U1	RU	BDX	Key1
182TC/184TC	36,37	7.25	8.50	.50	1.125	5.26	9.00	1/4 Sq.
213TC/215TC	All	7.25	8.50	.50	1.375	5.26	9.00	5/16 Sq.
254TC/256TC	All	7.25	8.50	.50	1.625	6.12	9.00	3/8 Sq.
284TC/286TC	All	9.00	10.50	.50	1.875	7.09	11.25	1/2 Sq.
324TC/326TC	All	11.00	12.50	.625	2.125 <sup>4</sup>	8.45	13.38	1/2 Sq.
364TC/365TC	37, 38	11.00	12.50	.625	2.375 <sup>4</sup>	8.45	13.38	5/8 Sq.

<sup>1</sup> Dimension "D" will never be exceeded, but may vary from values shown. When exact dimensions are required, shims up to .03" may be necessary.  
<sup>2</sup> All rough casting dimensions may vary by .25" due to casting variations.

<sup>3</sup> Output shaft extension tolerances: +.0000"; -.0005" for shafts up to 1.5" diameter "U". Larger diameter "U", +.000"; -.001".

<sup>4</sup> These frames utilize coupling input. This is input bore for coupling provided.

## Combined Output Shafted Flange Mount OtN32 - 35

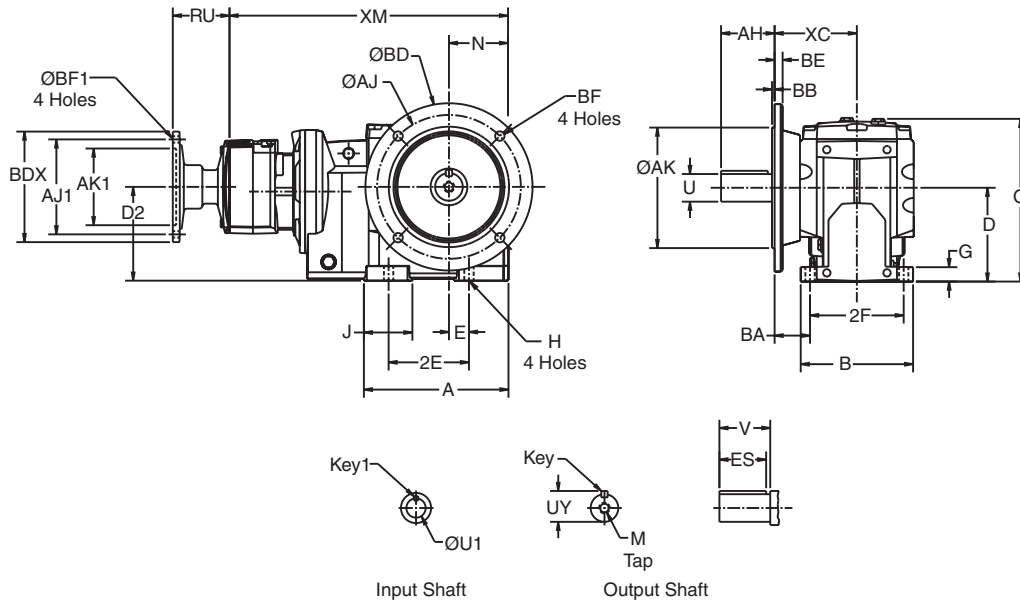

# OtN Series

Gear Frame	Version	A	B	D <sup>1</sup>	D <sub>2</sub>	E	2E	2F	G	H	J	O	N	BA	XC	XM
32	S1,S2	7.81	5.71	4.41	4.06	1.38	5.12	4.71	.73	.43	2.34	8.09	3.03	1.81	4.04	14.49
33,33A	S1,S2	8.50	6.61	5.51	4.91	1.18	4.72	5.51	.85	.55	2.86	9.69	3.54	2.24	4.84	19.90 <sup>4</sup>
34	S1,S2	10.13	7.87	7.09	5.57	1.57	5.91	6.50	1.07	.71	2.67	12.05	4.49	1.93	5.18	21.55
35	S2	11.92	8.66	8.35	6.56	2.17	7.09	7.09	1.18	.87	3.45	13.58	5.20	2.22	5.76	23.87

### Output Shaft

Gear Frame	Version	U <sup>3</sup>	UY	V	AH	Key	ES	M
32	S2	1.250	1.354	2.38	2.36	1/4 Sq.	2.06	1/2-13 X 1.12
	S1	1.250	1.354	1.77	1.75	1/4 Sq.	1.45	1/2-13 X 1.12
33,33A	S2	1.625	1.783	3.25	3.15	3/8 Sq.	2.78	5/8-11 X 1.38
	S1	1.500	1.657	3.18	2.28	3/8 Sq.	2.19	5/8-11 X 1.38
34	S2	2.000	2.210	3.94	3.94	1/2 Sq.	3.06	3/4-10 X 1.61
	S1	1.750	1.909	3.56	3.28	3/8 Sq.	3.56	3/4-10 X 1.61
35	S2	2.375	2.638	4.72	4.72	5/8 Sq.	3.81	3/4-10 X 1.61

### Output Flange

Gear Frame	Flange Code	AK	AJ	BB	BD	BE	BF
32	5	5.118	6.50	.14	7.87	.39	.47
	6	7.087	8.46	.16	9.84	.47	.55
33,33A	5	7.087	8.46	.16	9.84	.47	.55
	6	9.055	10.43	.16	11.81	.47	.55
34	5	9.055	10.43	.16	11.81	.59	.55
	6	9.842	11.80	.16	13.77	.59	.71
35	5	9.842	11.80	.20	13.77	.71	.71
	6	11.810	13.77	.20	15.75	.71	.71

### C-Face Input

Motor Frame	Gear Frame	AJ1	AK1	BF1	U1	RU	BDX	Key1
56C	32,33A	5.88	4.50	.38	.625	3.33	6.50	3/16 Sq.
	33,34,35	5.88	4.50	.38	.625	3.54	6.50	3/16 Sq.
143TC/145TC	32,33A	5.88	4.50	.38	.875	3.33	6.50	3/16 Sq.
	33,34,35	5.88	4.50	.38	.875	3.54	6.50	3/16 Sq.
182TC/184TC	33,34,35	7.25	8.50	.50	1.125	5.26	9.00	1/4 Sq.

<sup>1</sup> Dimension "D" will never be exceeded, but may vary from values shown. When exact dimensions are required, shims up to .03" may be necessary.

<sup>2</sup> All rough casting dimensions may vary by .25" due to casting variations.  
<sup>3</sup> Output shaft extension tolerances: +.0000"; -.0005" for shafts up to 1.5" diameter "U". Larger diameter "U", +.000"; -.001".

<sup>4</sup> XM dimension when gear frame 33A is used will be 16.42.

## Combined Output Shafted Flange Mount OtN36 - 38

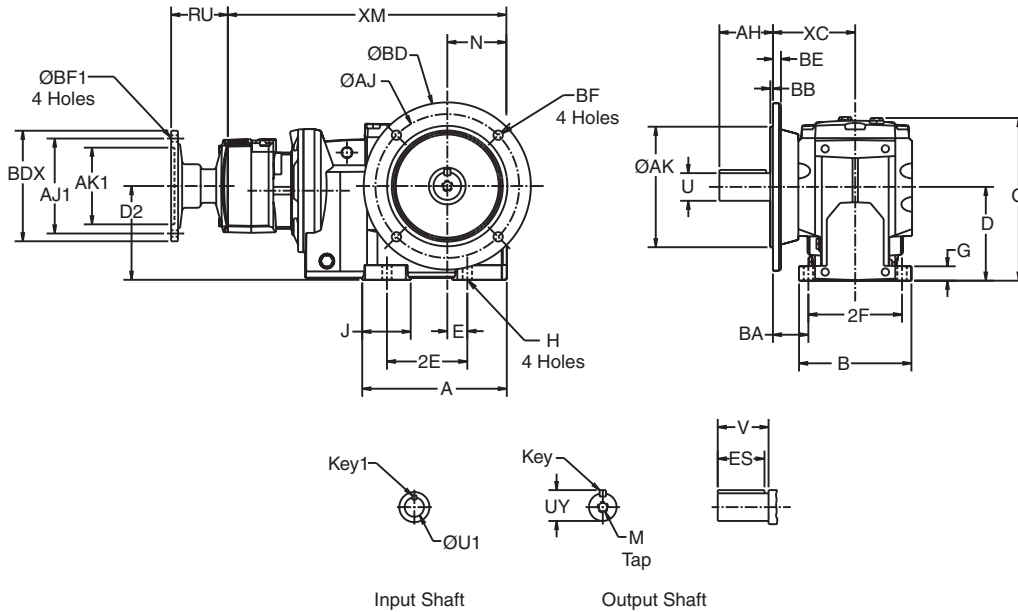

OtN Series

Gear Frame	Version	A	B	D <sup>1</sup>	D2	E	2E	2F	G	H	J	O	N	BA	XC	XM
																56-215TC
36	S2	17.06	11.41	8.86	8.46	6.99	13.98	9.45	1.57	.87	3.87	16.26	8.74	4.45	9.17	31.04
37	S2	20.58	12.99	9.84	10.57	8.27	16.54	10.63	1.93	.94	4.78	18.29	10.04	4.45	9.76	36.37
38	S2	17.85	13.39	14.76	11.48	4.53	13.78	10.63	1.98	1.26	4.06	24.11	8.86	4.65	9.96	31.94

### Output Shaft

Gear Frame	Version	U <sup>3</sup>	UY	V	AH	Key	ES	M
36 & 37	S2	2.875	3.20	7.68	5.51	3/4 SQ.	5.00	3/4-10 X 1.61
	S2	3.625	4.01	8.88	6.69	7/8 SQ.	6.00	1-8 X 2.13
38	S2	4.375	4.809	8.99	9.97	1.00 SQ.	7.00	1-8 X 2.25

### Output Flange

Gear Frame	Flange Code	AK	AJ	BB	BD	BE	BF
36 & 37	5	13.78	15.75	.236	17.70	.79	.71
	6	17.72	19.68	.236	21.65	.63	.87
38	5	17.72	19.69	.200	21.65	.79	.69
	6	21.65	23.62	.236	25.98	.63	.87

Motor Frame	Gear Frame	AJ1	AK1	BF1	U1	RU	BDX	Key1
56C	All	5.88	4.50	.38	.625	3.54	6.50	3/16 Sq.
143TC/145TC	All	5.88	4.50	.38	.875	3.54	6.50	3/16 Sq.
182TC/184TC	All	7.25	8.50	.50	1.125	5.26	9.00	1/4 Sq.
213TC/215TC	All	7.25	8.50	.50	1.375	5.26	9.00	5/16 Sq.
254TC/256TC	38	9.00	10.50	.50	1.875	7.09	11.02	1/2 Sq.

<sup>1</sup> Dimension "D" will never be exceeded, but may vary from values shown. When exact dimensions are required, shims up to .03" may be necessary. <sup>2</sup> All rough casting dimensions may vary by .25" due to casting variations. <sup>3</sup> Output shaft extension tolerances: +.0000"; -.0005" for shafts up to 1.5" diameter "U". Larger diameter "U", +.000"; -.001".

## 2-Stage Finished Bore Hollow Shaft OtN31 - 32

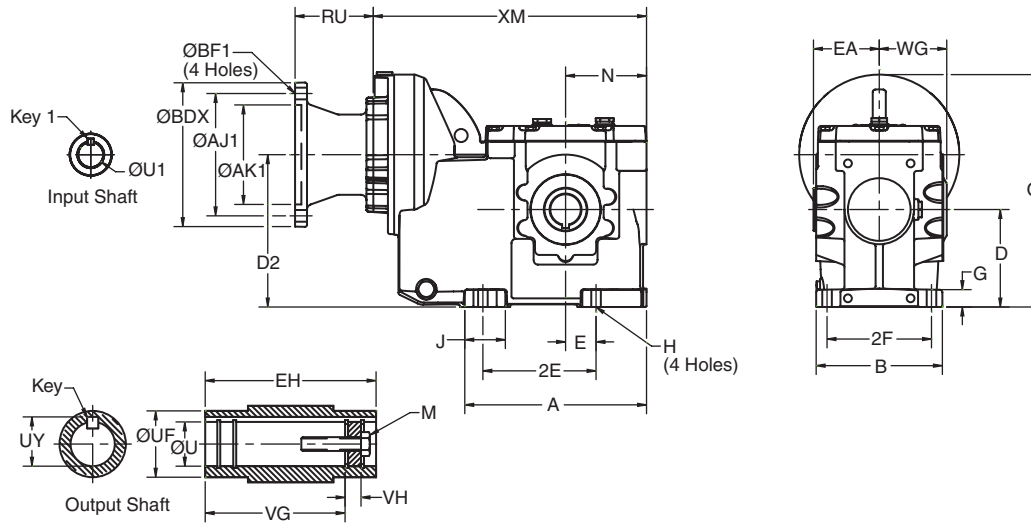

OtN Series

Gear Frame	Version	A	B	D <sup>1</sup>	D2	E	2E	2F	G	H	J	O	N	WG	XM
3132	S2	5.88	4.65	3.15	4.98	1.97	3.94	3.94	.56	.35	1.53	8.01	3.15	2.85	10.59
3242	S2	8.22	5.71	4.41	6.89	1.38	5.12	4.72	.79	.43	1.83	10.51	3.66	3.22	12.36

### Output Shaft

Gear Frame	Version	EA	EH	U <sup>3,5,6</sup>	UF	UY	VG	VH	Key <sup>7</sup>	M
3132	S2	2.56	5.12	1.250	1.77	1.372	4.31	.37	1/4 X 1/4 X 1 1/2	7/16-14 X 1.00
3242	S2	2.97	5.94	1.375	1.96	1.523	5.06	.37	5/16 X 5/16 1 13/16	1/2-13 X 1.00

Motor Frame	Gear Frame	AJ1	AK1	BF1	U1	RU	BDX	Key1
56C	Any	5.88	4.50	.38	.625	3.54	6.50	3/16 Sq.
143TC/145TC	Any	5.88	4.50	.38	.875	3.54	6.50	3/16 Sq.
182TC/184TC	32	7.25	8.50	.50	1.125	5.26	9.00	1/4 Sq.

<sup>1</sup> Dimension "D" will never be exceeded, but may vary from values shown. When exact dimensions are required, shims up to .03" may be necessary.  
<sup>2</sup> All rough casting dimensions may vary by .25" due to casting variations.  
<sup>3</sup> Driven shaft entry can be from either side of the gear reducer housing by reversing positioning of the snap rings and washer illustrated.

<sup>4</sup> For details of the torque arm kit, refer to page B-129.  
<sup>5</sup> Output bore tolerances: +.0020", -.0000" for all diameters.  
<sup>6</sup> Refer to page B-133 by gear frame for Tapered Bushed designs if driven shaft varies from "U" dimensions offered above.  
<sup>7</sup> Key not supplied with reducer.

## 3-Stage Finished Bore Hollow Shaft OtN32 - 35

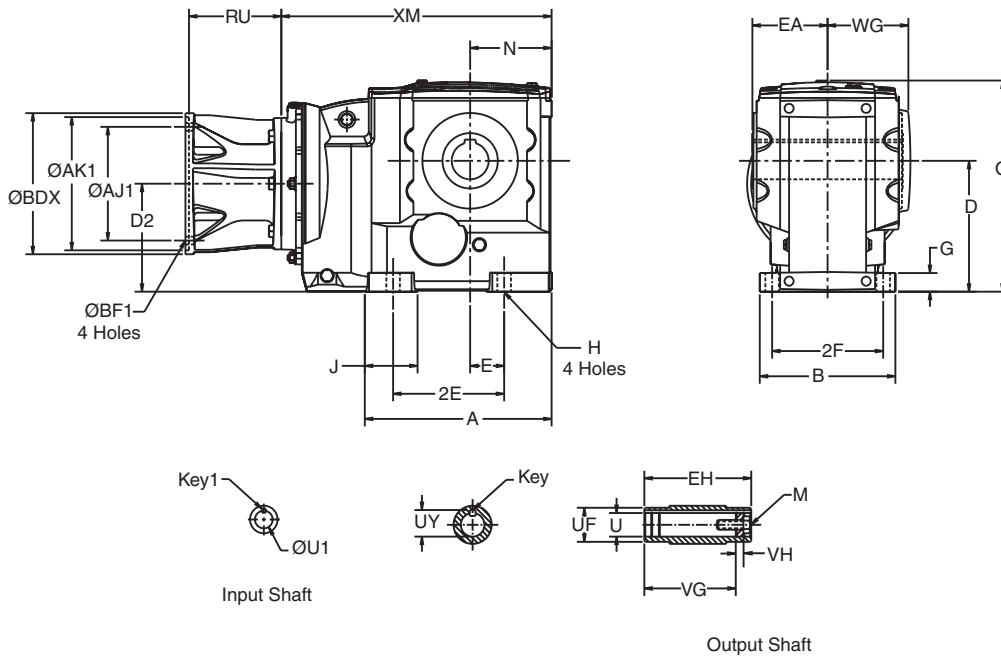

Gear Frame	Version	A	B	D <sup>1</sup>	D2	E	2E	2F	G	H	J	O	N	WG	XM	
															56C-215TC	254TC-286TC
32	S2	7.81	5.71	4.41	3.78	1.38	5.12	4.71	.73	.43	2.34	8.09	3.03	3.22	10.98	-
33	S2	8.50	6.61	5.51	5.24	1.18	4.72	5.51	.85	.55	2.86	9.69	3.54	3.73	12.90	-
34	S2	10.13	7.87	7.09	5.90	1.57	5.91	6.50	1.07	.71	2.67	12.05	4.49	4.66	14.56	-
35	S2	11.92	8.66	8.35	6.89	2.17	7.09	7.09	1.18	.87	3.45	13.58	5.20	5.15	16.90	17.25

### Output Shaft

Gear Frame	Version	EA	EH	U <sup>6,7</sup>	UF	UY	VG	VH	Key <sup>4</sup>	M
32	S2	2.98	5.95	1.375	1.96	1.523	5.20	.55	5/16 X 5/16 X 1 13/16	1/2-13 X 1.00
33	S2	3.47	6.94	1.500	2.16	1.674	5.96	.55	3/8 X 3/8 X 2 1/4	5/8-11 X 1.75
34	S2	4.49	8.97	2.000	2.56	2.210	7.44	.79	1/2 X 7/16 X 2 5/8	5/8-11 X 1.75
35	S2	4.83	9.66	2.375	3.54	2.656	8.15	.94	5/8 X 5/8 X 3 5/8	3/4-10 X 2.00

### C-Face Input

Motor Frame	Gear Frame	AJ1	AK1	BF1	U1	RU	BDX	Key1
56C	Any	5.88	4.50	.38	.625	3.54	6.50	3/16 Sq.
143TC/145TC	Any	5.88	4.50	.38	.875	3.54	6.50	3/16 Sq.
182TC/184TC	Any	7.25	8.50	.50	1.125	5.26	9.00	1/4 Sq.
213TC/215TC	33,34,35	7.25	8.50	.50	1.375	5.26	9.00	5/16 Sq.
254TC/256TC	35	7.25	8.50	.50	1.625	6.12	9.00	3/8 Sq.
284TC/286TC	35	9.00	10.50	.50	1.875	7.09	11.25	1/2 Sq.

<sup>1</sup> Dimension "D" will never be exceeded, but may vary from values shown. When exact dimensions are required, shims up to .03" may be necessary.  
<sup>2</sup> All rough casting dimensions may vary by .25" due to casting variations.  
<sup>3</sup> Driven shaft entry can be from either side of the gear reducer housing by reversing positioning of the snap rings and washer illustrated.

<sup>4</sup> Output key supplied only on frame 34 in "S2" version.  
<sup>5</sup> For details of the torque arm kit, refer to page B-129.  
<sup>6</sup> Output bore tolerances: +.0020", -.0000" for all diameters.  
<sup>7</sup> Refer to page B-133 by gear frame for Tapered Bushed designs if driven shaft varies from "U" dimensions offered above.

## 3-Stage Finished Bore Hollow Shaft OtN36 - 38

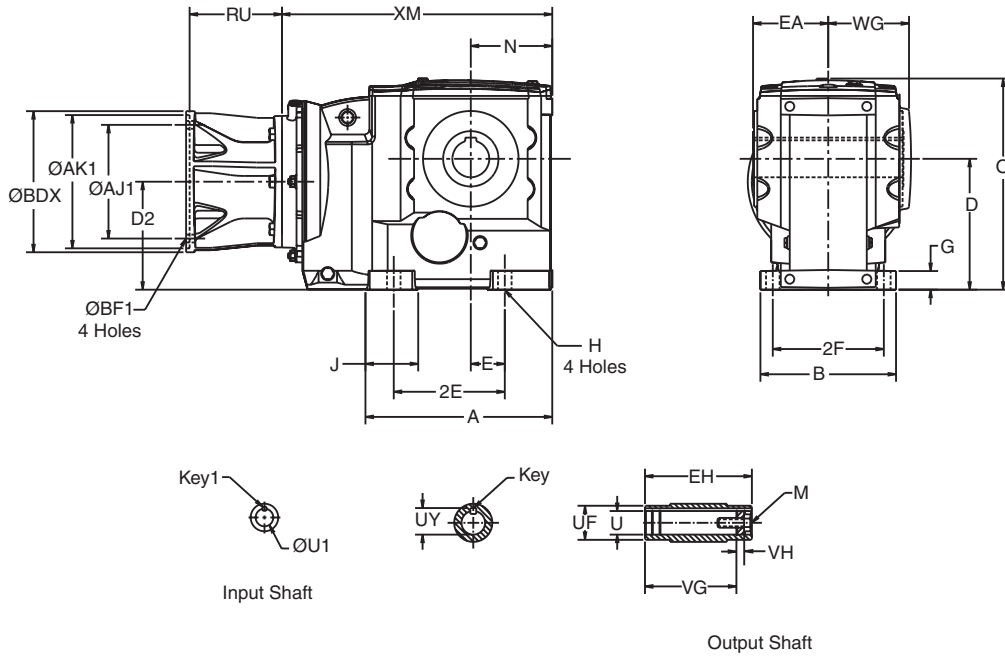

OtN Series

Gear Frame	Version	A	B	D <sup>1</sup>	D2	E	2E	2F	G	H	J	O	N	WG	XM	
															182-215TC	254-365TC
36	S2	17.06	11.41	8.86	8.86	6.99	13.98	9.45	1.57	.87	3.87	16.26	8.74	6.78	23.38	23.73
37	S2	20.58	12.99	9.84	10.98	8.27	16.54	10.63	1.93	.94	4.78	18.29	10.04	7.44	23.38	29.06
38	S2	17.85	13.39	14.76	11.87	4.53	13.78	10.63	1.98	1.26	4.06	24.11	8.86	7.40	24.29	24.64

### Output Shaft

Gear Frame	Version	EA	EH	U <sup>3.5</sup>	UF	UY	VG	VH	Key <sup>6</sup>	M
36	S2	6.22	12.44	2.750	3.93	3.037	10.89	1.23	5/8 X 5/8 X 5 1/2	3/4-10 X 2.00
37	S2	6.80	13.59	3.625	4.72	4.019	11.90	1.23	7/8 X 7/8 X 5 1/2	3/4-10 X 2.00
38	S2	6.81	13.74	4.000	5.50	4.316	11.86	.92	1 X 1 X 6 1/2	1-8 X 2.25

Motor Frame	Gear Frame	AJ1	AK1	BF1	U1	RU	BDX	Key1
182TC/184TC	36,37	7.25	8.50	.50	1.125	5.26	9.00	1/4 Sq.
213TC/215TC	All	7.25	8.50	.50	1.375	5.26	9.00	5/16 Sq.
254TC/256TC	All	7.25	8.50	.50	1.625	6.12	9.00	3/8 Sq.
284TC/286TC	All	9.00	10.50	.50	1.875	7.09	11.25	1/2 Sq.
324TC/326TC	All	11.00	12.50	.625	2.125 <sup>7</sup>	8.45	13.38	1/2 Sq.
364TC/365TC	37, 38	11.00	12.50	.625	2.375 <sup>7</sup>	8.45	13.38	5/8 Sq.

<sup>1</sup> Dimension "D" will never be exceeded, but may vary from values shown. When exact dimensions are required, shims up to .03" may be necessary.  
<sup>2</sup> All rough casting dimensions may vary by .25" due to casting variations.  
<sup>3</sup> Driven shaft entry can be from either side of the gear reducer housing by reversing positioning of the snap rings and washer illustrated.

<sup>4</sup> For details of the torque arm kit, refer to pages B-129 and B-130.  
<sup>5</sup> Output bore tolerances: +.0020", -.0000" for all diameters.  
<sup>6</sup> Key not supplied with reducer.  
<sup>7</sup> These frames utilize coupling input. This is input bore for coupling provided.



## Combined Finished Bore Hollow Shaft OtN32 - 35

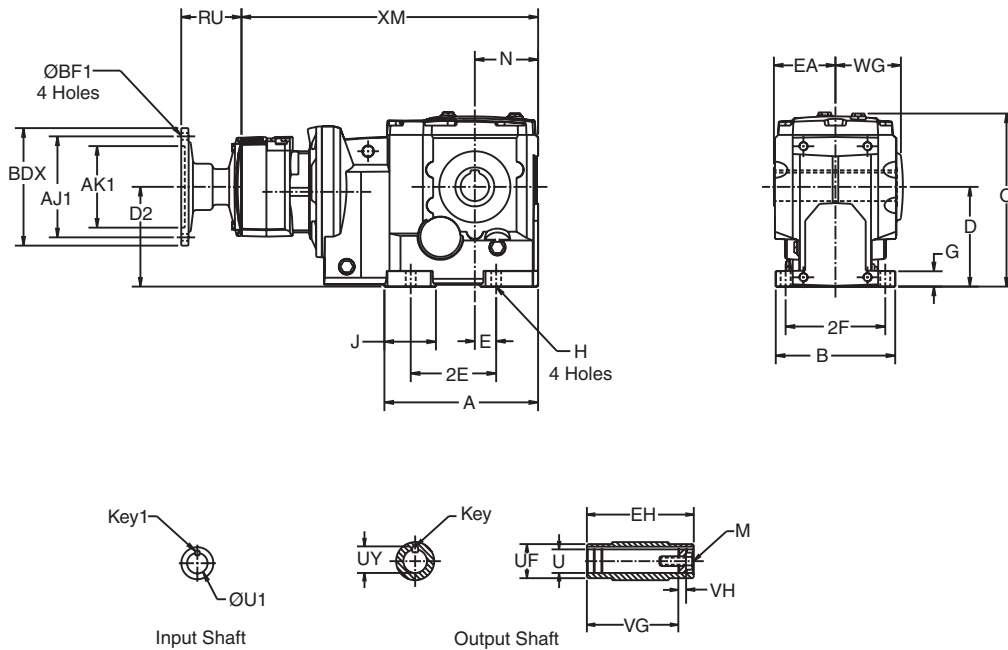

Gear Frame	Version	A	B	D <sup>1</sup>	D2	E	2E	2F	G	H	J	O	N	WG	XM
32	S2	7.81	5.71	4.41	4.06	1.38	5.12	4.71	.73	.43	2.34	8.09	3.03	3.22	14.49
33,33A	S2	8.50	6.61	5.51	4.91	1.18	4.72	5.51	.85	.55	2.86	9.69	3.54	3.73	19.90 <sup>8</sup>
34	S2	10.13	7.87	7.09	5.57	1.57	5.91	6.50	1.07	.71	2.67	12.05	4.49	4.66	21.55
35	S2	11.92	8.66	8.35	6.56	2.17	7.09	7.09	1.18	.87	3.45	13.58	5.20	5.15	23.87

### Output Shaft

Gear Frame	Version	EA	EH	U <sup>3,7</sup>	UF	UY	VG	VH	Key <sup>5</sup>	M
32	S2	2.98	5.95	1.375	1.96	1.523	5.20	.55	5/16 X 5/16 X 1 13/16	1/2-13 X 1.00
33,33A	S2	3.47	6.94	1.500	2.16	1.674	5.96	.55	3/8 X 3/8 X 2 1/4	5/8-11 X 1.75
34	S2	4.49	8.97	2.000	2.56	2.210	7.44	.79	1/2 X 7/16 X 2 5/8	5/8-11 X 1.75
35	S2	4.83	9.66	2.375	3.54	2.656	8.15	.94	5/8 X 5/8 X 3 5/8	3/4-10 X 2.00

### C-Face Input

Motor Frame	Gear Frame	AJ1	AK1	BF1	U1	RU	BDX	Key1
56C	32,33A	5.88	4.50	.38	.625	3.33	6.50	3/16 Sq.
	33,34,35	5.88	4.50	.38	.625	3.54	6.50	3/16 Sq.
143TC/145TC	32,33A	5.88	4.50	.38	.875	3.33	6.50	3/16 Sq.
	33,34,35	5.88	4.50	.38	.875	3.54	6.50	3/16 Sq.
182TC/184TC	33,34,35	7.25	8.50	.50	1.125	5.26	9.00	1/4 Sq.

<sup>1</sup> Dimension "D" will never be exceeded, but may vary from values shown. When exact dimensions are required, shims up to .03" may be necessary.

<sup>2</sup> All rough casting dimensions may vary by .25" due to casting variations.

<sup>3</sup> Refer to page B-133 by gear frame for Tapered Bushed designs if driven shaft varies from "U" dimension offered above.

<sup>4</sup> Driven shaft entry can be from either side of the gear reducer housing by reversing positioning of the snap rings and washer illustrated.

<sup>5</sup> Output key supplied only on frame 34 in "S2" version.

<sup>6</sup> For details of the torque arm kit, refer to page B-129.

<sup>7</sup> Output bore tolerances: +.0020", -.0000" for all diameters.

<sup>8</sup> XM dimension when gear frame 33A is used will be 16.42.

## Combined Finished Bore Hollow Shaft OtN36 - 38

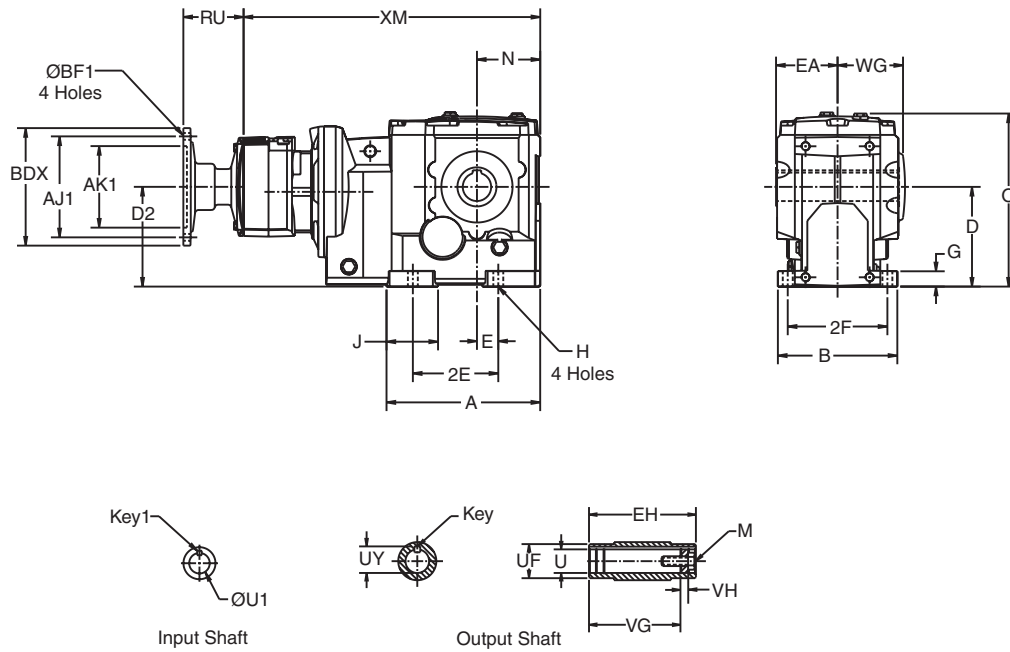

OtN Series

Gear Frame	Version	A	B	D <sup>1</sup>	D2	E	2E	2F	G	H	J	O	N	WG	XM
															56-215TC
36	S2	17.06	11.41	8.86	8.46	6.99	13.98	9.45	1.57	.87	3.87	16.26	8.74	6.78	31.04
37	S2	20.58	12.99	9.84	10.57	8.27	16.54	10.63	1.93	.94	4.78	18.29	10.04	7.44	36.37
38	S2	17.85	13.39	14.76	11.48	4.53	13.78	10.63	1.98	1.26	4.06	24.11	8.86	7.40	31.94

### Output Shaft

Gear Frame	Version	EA	EH	U <sup>3,5</sup>	UF	UY	VG	VH	Key <sup>6</sup>	M
36	S2	6.22	12.44	2.750	3.93	3.037	10.89	1.23	5/8 X 5/8 X 5 1/2	3/4-10 X 2.00
37	S2	6.80	13.59	3.625	4.72	4.019	11.90	1.23	7/8 X 7/8 X 5 1/2	3/4-10 X 2.00
38	S2	6.81	13.74	4.000	5.50	4.316	11.86	.92	1 X 1 X 6 1/2	1-8 X 2.25

Motor Frame	Gear Frame	AJ1	AK1	BF1	U1	RU	BDX	Key1
56C	All	5.88	4.50	.38	.625	3.54	6.50	3/16 Sq.
143TC/145TC	All	5.88	4.50	.38	.875	3.54	6.50	3/16 Sq.
182TC/184TC	All	7.25	8.50	.50	1.125	5.26	9.00	1/4 Sq.
213TC/215TC	All	7.25	8.50	.50	1.375	5.26	9.00	5/16 Sq.

<sup>1</sup> Dimension "D" will never be exceeded, but may vary from values shown. When exact dimensions are required, shims up to .03" may be necessary.

<sup>2</sup> All rough casting dimensions may vary by .25" due to casting variations.

<sup>3</sup> Driven shaft entry can be from either side of the gear reducer housing

by reversing positioning of the snap rings and washer illustrated.

<sup>4</sup> For details of the torque arm kit, refer to pages B-129 and B-130.

<sup>5</sup> Output bore tolerances: +.0020", -.0000" for all diameters.

<sup>6</sup> Key not supplied with reducer.

## 2-Stage Finished Bore Hollow Shaft Face Mount OtN31 - 32

OtN Series

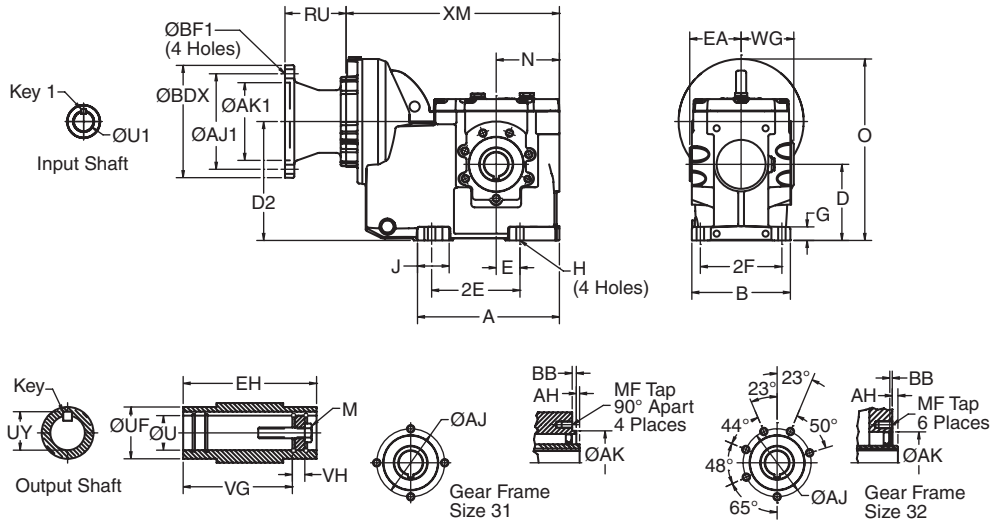

Gear Frame	Version	A	B	D <sup>1</sup>	D2	E	2E	2F	G	H	J	O	N	WG	XM
3132	S2	5.88	4.65	3.15	4.98	1.97	3.94	3.94	.56	.35	1.53	8.01	3.15	2.85	10.59
3242	S2	8.22	5.71	4.41	6.89	1.38	5.12	4.72	.79	.43	1.83	10.51	3.66	3.22	12.36

### Output Shaft

Gear Frame	Version	EA	EH	U <sup>3,4</sup>	UF	UY	VG	VH	Key <sup>5</sup>	M
3132	S2	2.56	5.12	1.250	1.77	1.372	4.31	.37	1/4 X 1/4 X 1 1/2	7/16-14 X 1.00
3242	S2	2.97	5.94	1.375	1.96	1.523	5.06	.37	5/16 X 5/16 1 13/16	1/2-13 X 1.00

### Face Mount

Gear Frame	Version	AH	AJ	AK	BB	MF
31	S2	.20	3.740	3.35	.14	M8-1.25 X 12
32	S2	.12	3.94	3.15	.16	M10-1.50 X 22

Motor Frame	Gear Frame	AJ1	AK1	BF1	U1	RU	BDX	Key1
56C	Any	5.88	4.50	.38	.625	3.54	6.50	3/16 Sq.
143TC/145TC	Any	5.88	4.50	.38	.875	3.54	6.50	3/16 Sq.
182TC/184TC	32	7.25	8.50	.50	1.125	5.26	9.00	1/4 Sq.

<sup>1</sup> Dimension "D" will never be exceeded, but may vary from values shown. When exact dimensions are required, shims up to .03" may be necessary.

<sup>2</sup> All rough casting dimensions may vary by .25" due to casting variations.

<sup>3</sup> Driven shaft entry can be from either side of the gear reducer housing by reversing positioning of the snap rings and washer illustrated.

<sup>4</sup> Output bore tolerances: +.0020", -.0000" for all diameters.

<sup>5</sup> Key not supplied with reducer.

## 3-Stage Finished Bore Hollow Shaft Face Mount OtN32 - 35

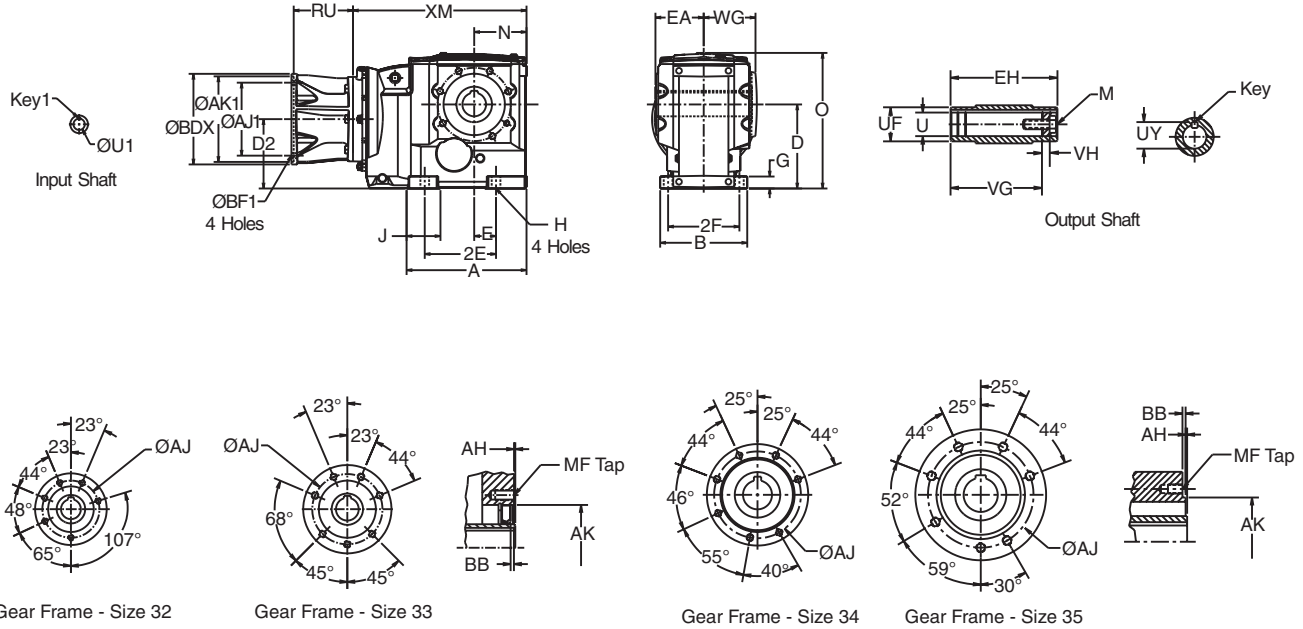

OtN Series

Gear Frame	Version	A	B	D <sup>1</sup>	D2	E	2E	2F	G	H	J	O	N	WG	XM	
															56C-215TC	254TC-286TC
32	S2	7.81	5.71	4.41	3.78	1.38	5.12	4.71	.73	.43	2.34	8.09	3.03	3.15	10.98	-
33	S2	8.50	6.61	5.51	5.24	1.18	4.72	5.51	.85	.55	2.86	9.69	3.54	3.63	12.90	-
34	S2	10.13	7.87	7.09	5.90	1.57	5.91	6.50	1.07	.71	2.67	12.05	4.49	4.66	14.56	-
35	S2	11.92	8.66	8.35	6.89	2.17	7.09	7.09	1.18	.87	3.45	13.58	5.20	5.15	16.90	17.25

### Output Shaft

Gear Frame	Version	EA	EH	U <sup>4</sup>	UF	UY	VG	VH	Key <sup>5</sup>	M
32	S2	2.98	5.95	1.375	1.96	1.523	5.20	.55	5/16 X 5/16 X 1 13/16	1/2-13 X 1.00
33	S2	3.47	6.94	1.500	2.16	1.674	5.96	.55	3/8 X 3/8 X 2 1/4	5/8-11 X 1.75
34	S2	4.49	8.97	2.000	2.56	2.210	7.44	.79	1/2 X 7/16 X 2 5/8	5/8-11 X 1.75
35	S2	4.83	9.66	2.375	3.54	2.656	8.15	.94	5/8 X 5/8 X 3 5/8	3/4-10 X 2.00

### Face Mount

Gear Frame	Version	AH	AJ	AK	BB	MF
32	S2	.12	3.94	3.15	.16	M10-1.50 X 22
33	S2	.12	4.84	3.94	.16	M12-1.75 X 22
34	S2	.14	5.98	5.12	.28	M12-1.75 X 22
35	S2	.13	7.48	6.10	.28	M16-2.00 X 27

### C-Face Input

Motor Frame	Gear Frame	AJ1	AK1	BF1	U1	RU	BDX	Key1
56C	Any	5.88	4.50	.38	.625	3.54	6.50	3/16 Sq.
143TC/145TC	Any	5.88	4.50	.38	.875	3.54	6.50	3/16 Sq.
182TC/184TC	Any	7.25	8.50	.50	1.125	5.26	9.00	1/4 Sq.
213TC/215TC	33,34,35	7.25	8.50	.50	1.375	5.26	9.00	5/16 Sq.
254TC/256TC	35	7.25	8.50	.50	1.625	6.12	9.00	3/8 Sq.
284TC/286TC	35	9.00	10.50	.50	1.875	7.09	11.25	1/2 Sq.

<sup>1</sup> Dimension "D" will never be exceeded, but may vary from values shown. When exact dimensions are required, shims up to .03" may be necessary.

<sup>2</sup> All rough casting dimensions may vary by .25" due to casting variations.

<sup>3</sup> Driven shaft entry can be from either side of the gear reducer housing

by reversing positioning of the snap rings and washer illustrated.

<sup>4</sup> Output bore tolerances: +.0020", -.0000" for all diameters.

<sup>5</sup> Output key supplied only on frame 34 in "S2" version.

## 3-Stage Finished Bore Hollow Shaft Face Mount OtN36 - 38

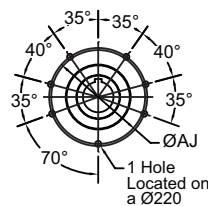
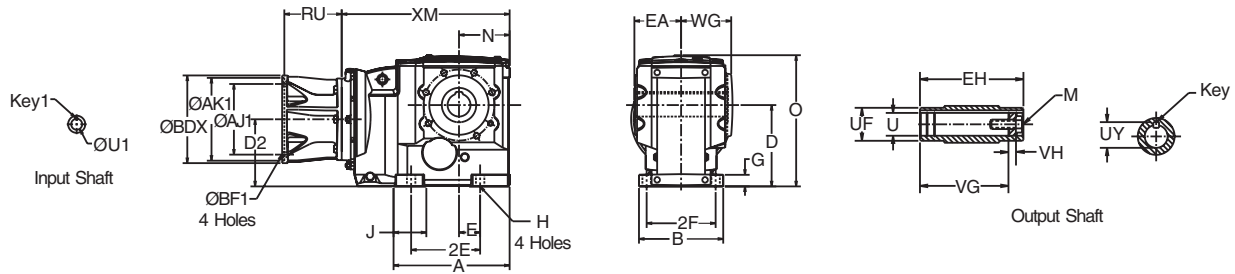

Gear Frame - Size 36

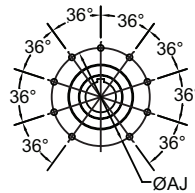

Gear Frame - Size 37

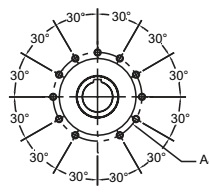

Gear Frame - Size 38

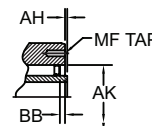

Gear Frame	Version	A	B	D <sup>1</sup>	D2	E	2E	2F	G	H	J	O	N	WG	XM	
															182-215TC	254-365TC
36	S2	17.06	11.41	8.86	8.86	6.99	13.98	9.45	1.57	.87	3.87	16.26	8.74	6.78	23.38	23.73
37	S2	20.58	12.99	9.84	10.98	8.27	16.54	10.63	1.93	.94	4.78	18.29	10.04	7.44	23.38	29.06
38	S2	17.85	13.39	14.76	11.87	4.53	13.78	10.63	1.98	1.26	4.06	24.11	8.86	7.40	24.29	24.64

### Output Shaft

Gear Frame	Version	EA	EH	U <sup>3,4</sup>	UF	UY	VG	VH	Key <sup>5</sup>	M
36	S2	6.22	12.44	2.750	3.93	3.037	10.89	1.23	5/8 X 5/8 X 5 1/2	3/4-10 X 2.00
37	S2	6.80	13.59	3.625	4.72	4.019	11.90	1.23	7/8 X 7/8 X 5 1/2	3/4-10 X 2.00
38	S2	6.81	13.74	4.000	5.50	4.316	11.86	.92	1 X 1 X 6 1/2	1-8 X 2.25

### Face Mount

Gear Frame	Version	AH	AJ	AK	BB	MF
36	S2	.20	9.06	5.91	.28	M16-2.0 X 27
37	S2	.20	9.06	7.09	.28	M20-2.5 X 35
38	S2	.10	11.81	9.84	.20	M20-2.00 X 35

Motor Frame	Gear Frame	AJ1	AK1	BF1	U1	RU	BDX	Key1
182TC/184TC	36,37	7.25	8.50	.50	1.125	5.26	9.00	1/4 Sq.
213TC/215TC	All	7.25	8.50	.50	1.375	5.26	9.00	5/16 Sq.
254TC/256TC	All	7.25	8.50	.50	1.625	6.12	9.00	3/8 Sq.
284TC/286TC	All	9.00	10.50	.50	1.875	7.09	11.25	1/2 Sq.
324TC/326TC	All	11.00	12.50	.625	2.125 <sup>6</sup>	8.45	13.38	1/2 Sq.
364TC/365TC	37, 38	11.00	12.50	.625	2.375 <sup>6</sup>	8.45	13.38	5/8 Sq.

<sup>1</sup> Dimension "D" will never be exceeded, but may vary from values shown. When exact dimensions are required, shims up to .03" may be necessary.  
<sup>2</sup> All rough casting dimensions may vary by .25" due to casting variations.  
<sup>3</sup> Driven shaft entry can be from either side of the gear reducer housing

by reversing positioning of the snap rings and washer illustrated.  
<sup>4</sup> Output bore tolerances: +.0020", -.0000" for all diameters.  
<sup>5</sup> Key not supplied with reducer.  
<sup>6</sup> These frames utilize coupling input. This is input bore for coupling provided.

**Combined Finished Bore Hollow Shaft Face Mount**  
**OtN32 - 35**

**OtN Series**

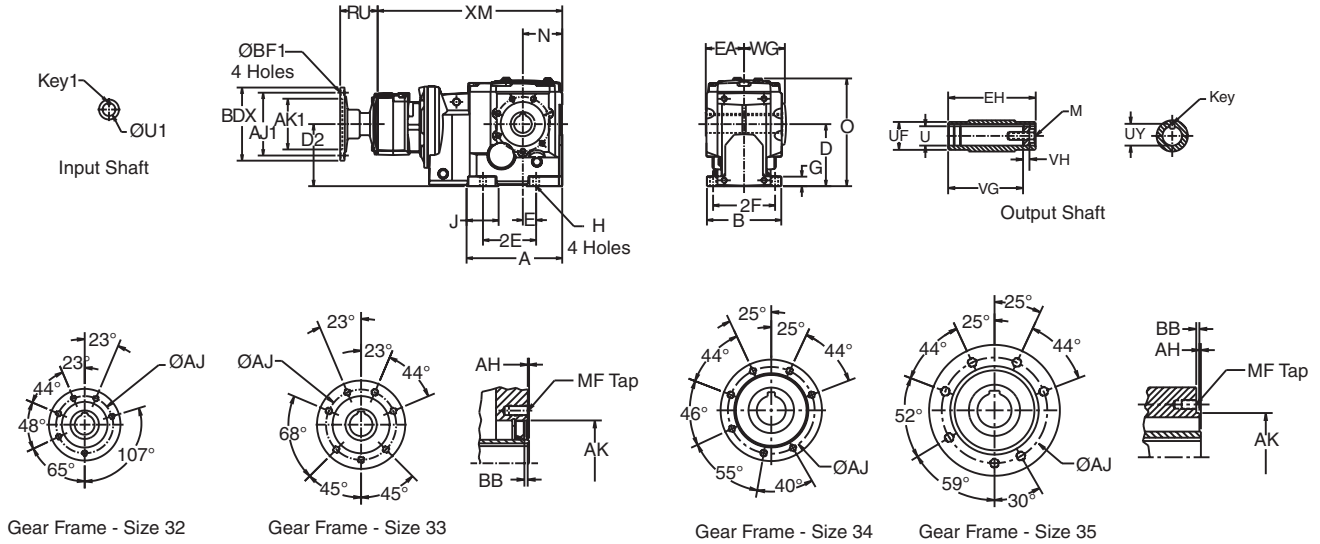

Gear Frame	Version	A	B	D <sup>1</sup>	D2	E	2E	2F	G	H	J	O	N	WG	XM
32	S2	7.81	5.71	4.41	4.06	1.38	5.12	4.71	.73	.43	2.34	8.09	3.03	3.15	14.49
33,33A	S2	8.50	6.61	5.51	4.91	1.18	4.72	5.51	.85	.55	2.86	9.69	3.54	3.63	19.90 <sup>3</sup>
34	S2	10.13	7.87	7.09	5.57	1.57	5.91	6.50	1.07	.71	2.67	12.05	4.49	4.66	21.55
35	S2	11.92	8.66	8.35	6.56	2.17	7.09	7.09	1.18	.87	3.45	13.58	5.20	5.15	23.87

**Output Shaft**

Gear Frame	Version	EA	EH	U <sup>4,5</sup>	UF	UY	VG	VH	Key <sup>6</sup>	M
32	S2	2.98	5.95	1.375	1.96	1.523	5.20	.55	5/16 X 5/16 X 1 13/16	1/2-13 X 1.00
33,33A	S2	3.47	6.94	1.500	2.16	1.674	5.96	.55	3/8 X 3/8 X 2 1/4	5/8-11 X 1.75
34	S2	4.49	8.97	2.000	2.56	2.210	7.44	.79	1/2 X 7/16 X 2 5/8	5/8-11 X 1.75
35	S2	4.83	9.66	2.375	3.54	2.656	8.15	.94	5/8 X 5/8 X 3 5/8	3/4-10 X 2.00

**Face Mount**

Gear Frame	Version	AH	AJ	AK	BB	MF
32	S2	.12	3.94	3.15	.16	M10-1.50 X 22
33,33A	S2	.12	4.84	3.94	.16	M12-1.75 X 22
34	S2	.14	5.98	5.12	.28	M12-1.75 X 22
35	S2	.13	7.48	6.10	.28	M16-2.00 X 27

**C-Face Input**

Motor Frame	Gear Frame	AJ1	AK1	BF1	U1	RU	BDX	Key1
56C	32,33A	5.88	4.50	.38	.625	3.33	6.50	3/16 Sq.
	33,34,35	5.88	4.50	.38	.625	3.54	6.50	3/16 Sq.
143TC/145TC	32,33A	5.88	4.50	.38	.875	3.33	6.50	3/16 Sq.
	33,34,35	5.88	4.50	.38	.875	3.54	6.50	3/16 Sq.
182TC/184TC	33,34,35	7.25	8.50	.50	1.125	5.26	9.00	1/4 Sq.

<sup>1</sup> Dimension "D" will never be exceeded, but may vary from values shown. When exact dimensions are required, shims up to .03" may be necessary.  
<sup>2</sup> All rough casting dimensions may vary by .25" due to casting variations.

<sup>3</sup> XM dimension when gear frame 33A is used will be 16.42.  
<sup>4</sup> Driven shaft entry can be from either side of the gear reducer housing by reversing positioning of the snap rings and washer illustrated.  
<sup>5</sup> Output bore tolerances: +.0020", -.0000" for all diameters.  
<sup>6</sup> Output key supplied only on frame 34 in "S2" version.

## Combined Finished Bore Hollow Shaft Face Mount OtN36 - 38

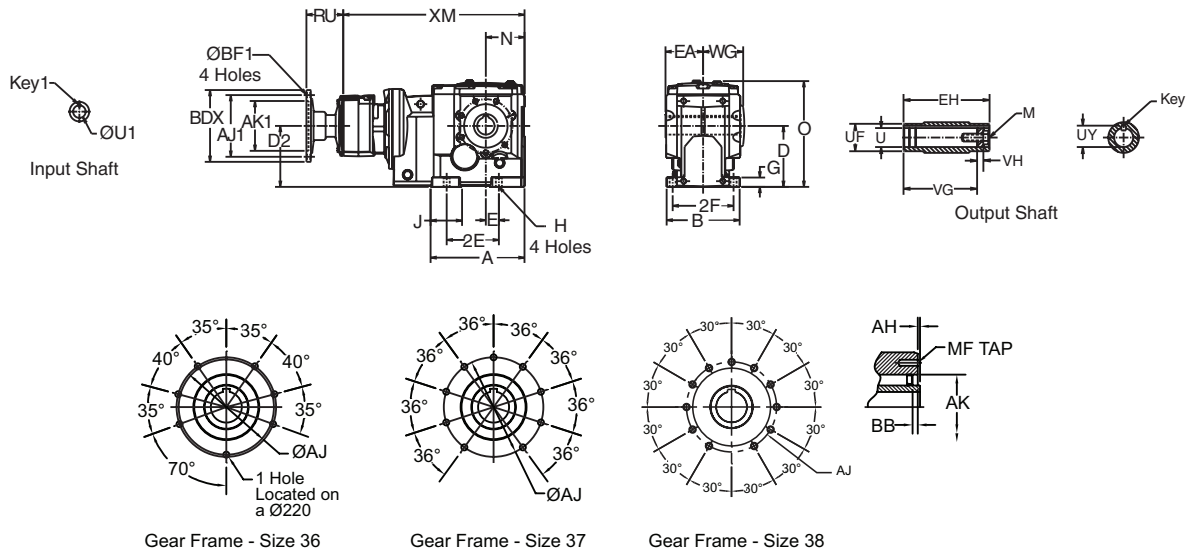

Gear Frame - Size 36

Gear Frame - Size 37

Gear Frame - Size 38

Gear Frame	Version	A	B	D <sup>1</sup>	D2	E	2E	2F	G	H	J	O	N	WG	XM
															56-215TC
36	S2	17.06	11.41	8.86	8.46	6.99	13.98	9.45	1.57	.87	3.87	16.26	8.74	6.78	31.04
37	S2	20.58	12.99	9.84	10.57	8.27	16.54	10.63	1.93	.94	4.78	18.29	10.04	7.44	36.37
38	S2	17.85	13.39	14.76	11.48	4.53	13.78	10.63	1.98	1.26	4.06	24.11	8.86	7.40	31.94

### Output Shaft

Gear Frame	Version	EA	EH	U <sup>3,4</sup>	UF	UY	VG	VH	Key <sup>5</sup>	M
36	S2	6.22	12.44	2.750	3.93	3.037	10.89	1.23	5/8 X 5/8 X 5 1/2	3/4-10 X 2.00
37	S2	6.80	13.59	3.625	4.72	4.019	11.90	1.23	7/8 X 7/8 X 5 1/2	3/4-10 X 2.00
38	S2	6.81	13.74	4.000	5.50	4.316	11.86	.92	1 X 1 X 6 1/2	1-8 X 2.25

### Face Mount

Gear Frame	Version	AH	AJ	AK	BB	MF
36	S2	.20	9.06	5.91	.28	M16-2.0 X 27
37	S2	.20	9.06	7.09	.28	M20-2.5 X 35
38	S2	.10	11.81	9.84	.20	M20-2.00 X 35

Motor Frame	Gear Frame	AJ1	AK1	BF1	U1	RU	BDX	Key1
56C	All	5.88	4.50	.38	.625	3.54	6.50	3/16 Sq.
143TC/145TC	All	5.88	4.50	.38	.875	3.54	6.50	3/16 Sq.
182TC/184TC	All	7.25	8.50	.50	1.125	5.26	9.00	1/4 Sq.
213TC/215TC	All	7.25	8.50	.50	1.375	5.26	9.00	5/16 Sq.

<sup>1</sup> Dimension "D" will never be exceeded, but may vary from values shown. When exact dimensions are required, shims up to .03" may be necessary.  
<sup>2</sup> All rough casting dimensions may vary by .25" due to casting variations.

<sup>3</sup> Driven shaft entry can be from either side of the gear reducer housing by reversing positioning of the snap rings and washer illustrated.  
<sup>4</sup> Output bore tolerances: +.0020", -.0000" for all diameters.

<sup>5</sup> Key not supplied with reducer.



**2-Stage Finished Bore Hollow Shaft Flange Mount**  
**OtN31 - 32**

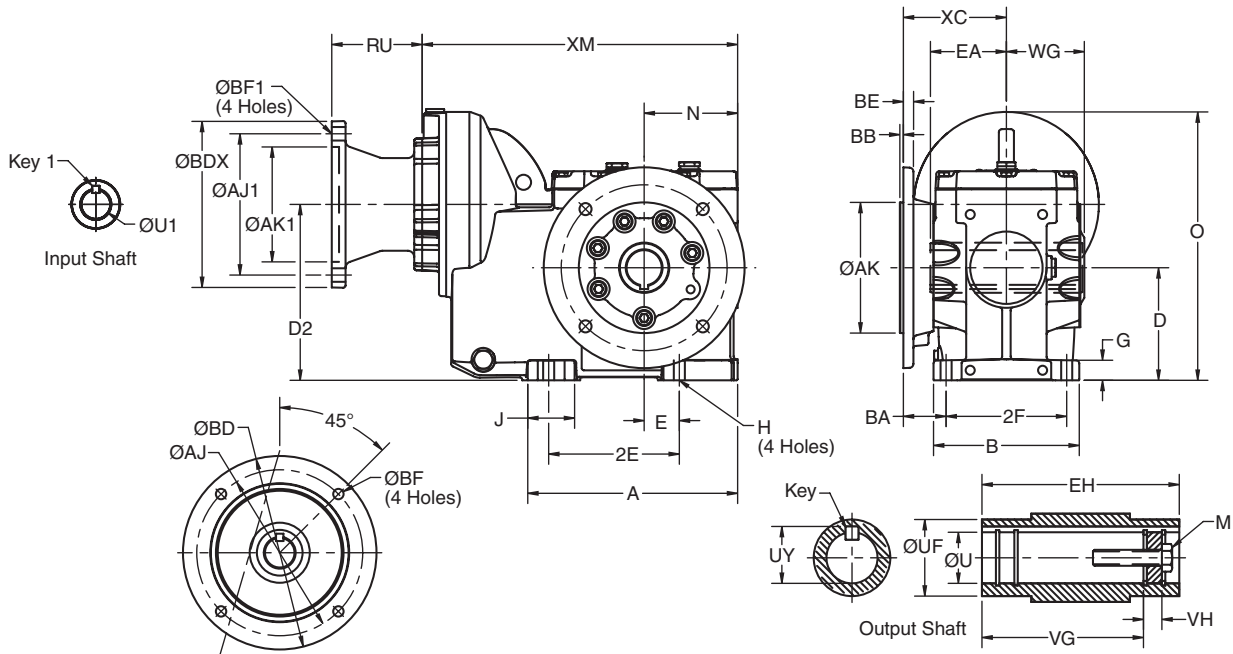

**OtN Series**

Gear Frame	Version	A	B	D <sup>1</sup>	D2	E	2E	2F	G	H	J	O	N	BA	WG	XC	XM
3132	S2	5.88	4.65	3.15	4.98	1.97	3.94	3.94	.56	.35	1.53	8.01	3.15	1.54	2.85	3.50	10.59
3242	S2	8.22	5.71	4.41	6.89	1.38	5.12	4.72	.79	.43	1.83	10.51	3.66	1.67	3.22	4.04	12.36

**Output Shaft**

Gear Frame	Version	EA	EH	U <sup>3,4</sup>	UF	UY	VG	VH	Key <sup>5</sup>	M
3132	S2	2.56	5.12	1.250	1.77	1.372	4.31	.37	1/4 X 1/4 X 1 1/2	7/16-14 X 1.00
3242	S2	2.97	5.94	1.375	1.96	1.523	5.06	.37	5/16 X 5/16 1 13/16	1/2-13 X 1.00

**Output Flange**

Gear Frame	Flange Code	AK	AJ	BB	BD	BE	BF
3132	5	4.331	5.12	.14	6.50	.39	.35
	6	3.740	4.53	.14	5.51	.44	.35
3242	5	5.118	6.50	.14	7.87	.39	.47
	6	7.087	8.46	.16	9.84	.47	.55

Motor Frame	Gear Frame	AJ1	AK1	BF1	U1	RU	BDX	Key1
56C	Any	5.88	4.50	.38	.625	3.54	6.50	3/16 Sq.
143TC/145TC	Any	5.88	4.50	.38	.875	3.54	6.50	3/16 Sq.
182TC/184TC	32	7.25	8.50	.50	1.125	5.26	9.00	1/4 Sq.

<sup>1</sup> Dimension "D" will never be exceeded, but may vary from values shown. When exact dimensions are required, shims up to .03" may be necessary.

<sup>2</sup> All rough casting dimensions may vary by .25" due to casting variations.

<sup>3</sup> Driven shaft entry can be from either side of the gear reducer housing by reversing positioning of the snap rings and washer illustrated.

<sup>4</sup> Output bore tolerances: +.0020", -.0000" for all diameters.

<sup>5</sup> Key not supplied with reducer.

3-Stage Finished Bore Hollow Shaft Flange Mount  
OtN32 - 35

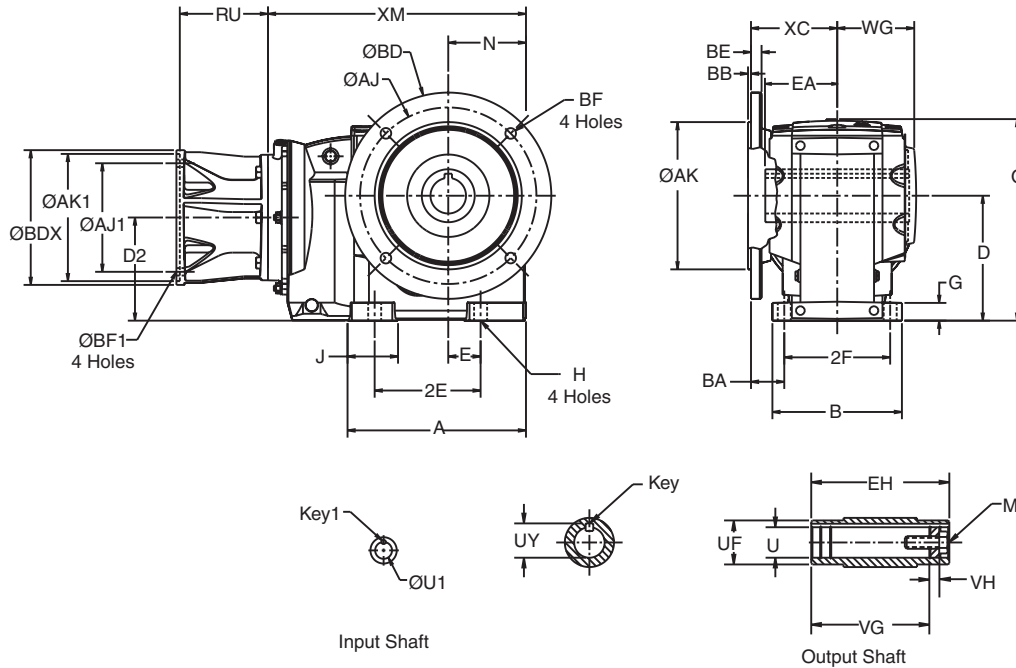

Gear Frame	Version	A	B	D <sup>1</sup>	D2	E	2E	2F	G	H	J	O	N	BA	WG	XC	XM	
																	56C-215TC	254TC-286TC
32	S2	7.81	5.71	4.41	3.78	1.38	5.12	4.71	.73	.43	2.34	8.09	3.03	1.81	3.22	4.04	10.98	-
33	S2	8.50	6.61	5.51	5.24	1.18	4.72	5.51	.85	.55	2.86	9.69	3.54	2.08	3.73	4.84	12.90	-
34	S2	10.13	7.87	7.09	5.90	1.57	5.91	6.50	1.07	.71	2.67	12.05	4.49	1.93	4.66	5.18	14.56	-
35	S2	11.92	8.66	8.35	6.89	2.17	7.09	7.09	1.18	.87	3.45	13.58	5.20	2.22	5.15	5.77	16.90	17.25

Output Shaft

Gear Frame	Version	EA	EH	U <sup>3,5</sup>	UF	UY	VG	VH	Key <sup>4</sup>	M
32	S2	2.98	5.95	1.375	1.96	1.523	5.20	.55	5/16 X 5/16 X 1 13/16	1/2-13 X 1.00
33	S2	3.47	6.94	1.500	2.16	1.674	5.96	.55	3/8 X 3/8 X 2 1/4	5/8-11 X 1.75
34	S2	4.49	8.97	2.000	2.56	2.210	7.44	.79	1/2 X 7/16 X 2 5/8	5/8-11 X 1.75
35	S2	4.83	9.66	2.375	3.54	2.656	8.15	.94	5/8 X 5/8 X 3 5/8	3/4-10 X 2.00

Output Flange

Gear Frame	Flange Code	AK	AJ	BB	BD	BE	BF
32	5	5.118	6.50	.14	7.87	.39	.47
	6	7.087	8.46	.16	9.84	.47	.55
33	5	7.087	8.46	.16	9.84	.47	.55
	6	9.055	10.43	.16	11.81	.47	.55
34	5	9.055	10.43	.16	11.81	.59	.55
	6	9.842	11.80	.16	13.77	.59	.71
35	5	9.842	11.80	.20	13.77	.71	.71
	6	11.810	13.77	.20	15.75	.71	.71

C-Face Input

Motor Frame	Gear Frame	AJ1	AK1	BF1	U1	RU	BDX	Key1
56C	Any	5.88	4.50	.38	.625	3.54	6.50	3/16 Sq.
143TC/145TC	Any	5.88	4.50	.38	.875	3.54	6.50	3/16 Sq.
182TC/184TC	Any	7.25	8.50	.50	1.125	5.26	9.00	1/4 Sq.
213TC/215TC	33,34,35	7.25	8.50	.50	1.375	5.26	9.00	5/16 Sq.
254TC/256TC	35	7.25	8.50	.50	1.625	6.12	9.00	3/8 Sq.
284TC/286TC	35	9.00	10.50	.50	1.875	7.09	11.25	1/2 Sq.

<sup>1</sup> Dimension "D" will never be exceeded, but may vary from values shown. When exact dimensions are required, shims up to .03" may be necessary.

<sup>2</sup> All rough casting dimensions may vary by .25" due to casting variations.  
<sup>3</sup> Driven shaft entry can be from either side of the gear reducer housing by reversing position of the snap rings and washer illustrated.

<sup>4</sup> Output key supplied only on frame 34 in "S2" version.

<sup>5</sup> Output bore tolerances: +.0020", -.0000" for all diameters.

3-Stage Finished Bore Hollow Shaft Flange Mount  
OtN36 - 38

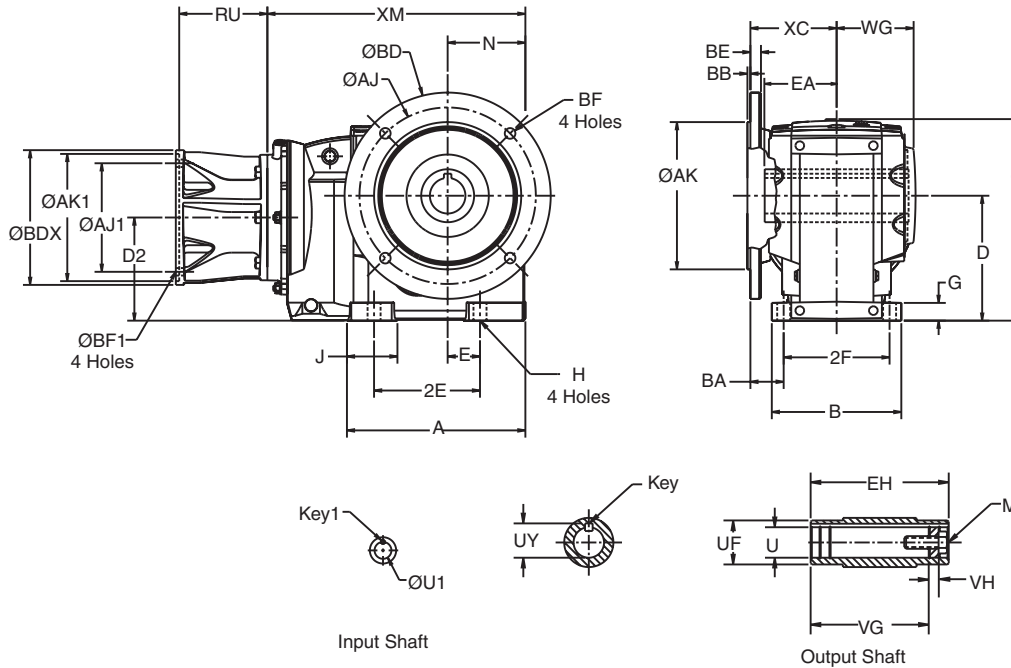

OtN Series

Gear Frame	Version	A	B	D <sup>1</sup>	D2	E	2E	2F	G	H	J	O	N	BA	WG	XC	XM	
																	182-215TC	254-365TC
36	S2	17.06	11.41	8.86	8.86	6.99	13.98	9.45	1.57	.87	3.87	16.26	8.74	4.45	6.78	9.17	23.38	23.73
37	S2	20.58	12.99	9.84	10.98	8.27	16.54	10.63	1.93	.94	4.78	18.29	10.04	4.45	7.44	9.76	23.38	29.06
38	S2	17.85	13.39	14.76	11.87	4.53	13.78	10.63	1.98	1.26	4.06	24.11	8.86	4.65	7.40	9.96	24.29	24.64

Output Shaft

Gear Frame	Version	EA	EH	U <sup>3,4</sup>	UF	UY	VG	VH	Key <sup>5</sup>	M
36	S2	6.22	12.44	2.750	3.93	3.037	10.89	1.23	5/8 X 5/8 X 5 1/2	3/4-10 X 2.00
37	S2	6.80	13.59	3.625	4.72	4.019	11.90	1.23	7/8 X 7/8 X 5 1/2	3/4-10 X 2.00
38	S2	6.81	13.74	4.000	5.50	4.316	11.86	.92	1 X 1 X 6 1/2	1-8 X 2.25

Output Flange

Gear Frame	Flange Code	AK	AJ	BB	BD	BE	BF
36 & 37	5	13.78	15.75	.236	17.70	.79	.71
	6	17.72	19.68	.236	21.65	.63	.87
38	5	17.72	19.69	.200	21.65	.79	.69
	6	21.65	23.62	.236	25.98	.63	.87

Motor Frame	Gear Frame	AJ1	AK1	BF1	U1	RU	BDX	Key1
182TC/184TC	All	7.25	8.50	.50	1.125	5.26	9.00	1/4 Sq.
213TC/215TC	All	7.25	8.50	.50	1.375	5.26	9.00	5/16 Sq.
254TC/256TC	All	7.25	8.50	.50	1.625	6.12	9.00	3/8 Sq.
284TC/286TC	All	9.00	10.50	.50	1.875	7.09	11.25	1/2 Sq.
324TC/326TC	All	11.00	12.50	.625	2.125 <sup>6</sup>	8.45	13.38	1/2 Sq.
364TC/365TC	All	11.00	12.50	.625	2.375 <sup>6</sup>	8.45	13.38	5/8 Sq.

<sup>1</sup> Dimension "D" will never be exceeded, but may vary from values shown. When exact dimensions are required, shims up to .03" may be necessary.

<sup>2</sup> All rough casting dimensions may vary by .25" due to casting variations.

<sup>3</sup> Driven shaft entry can be from either side of the gear reducer housing

by reversing positioning of the snap rings and washer illustrated.

<sup>4</sup> Output bore tolerances: +.0020", -.0000" for all diameters.

<sup>5</sup> Key not supplied with reducer.

<sup>6</sup> These frames utilize coupling input. This is input bore for coupling provided.

## Combined Finished Bore Hollow Shaft Flange Mount OtN32 - 35

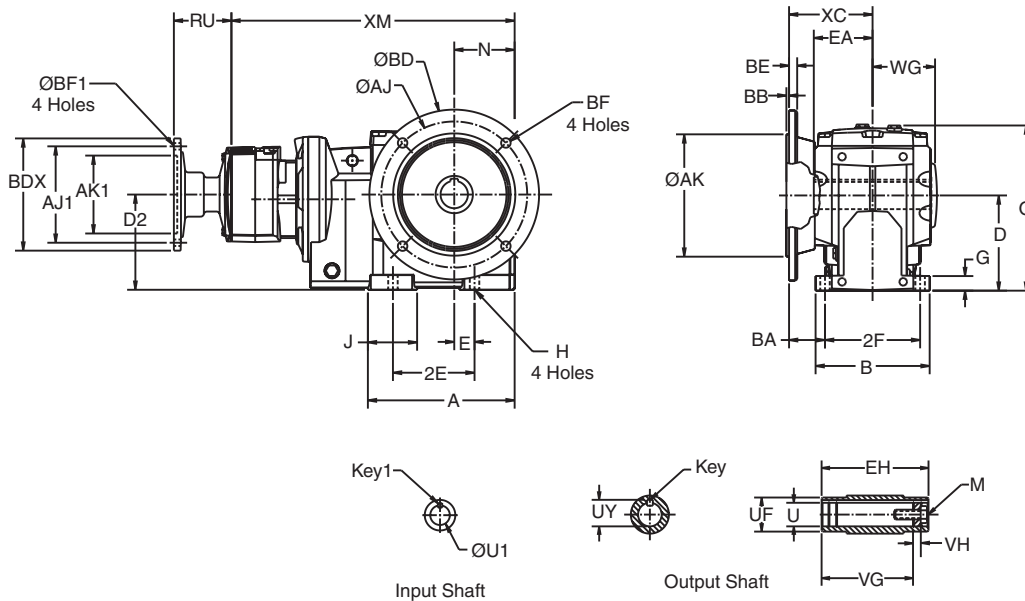

OtN Series

Gear Frame	Version	A	B	D <sup>1</sup>	D2	E	2E	2F	G	H	J	O	N	BA	WG	XC	XM
32	S2	7.81	5.71	4.41	4.06	1.38	5.12	4.71	.73	.43	2.34	8.09	3.03	1.81	3.22	4.04	14.49
33,33A	S2	8.50	6.61	5.51	4.91	1.18	4.72	5.51	.85	.55	2.86	9.69	3.54	2.08	3.73	4.84	19.90 <sup>3</sup>
34	S2	10.13	7.87	7.09	5.57	1.57	5.91	6.50	1.07	.71	2.67	12.05	4.49	1.93	4.66	5.18	21.55
35	S2	11.92	8.66	8.35	6.56	2.17	7.09	7.09	1.18	.87	3.45	13.58	5.20	2.22	5.15	5.77	23.87

### Output Shaft

Gear Frame	Version	EA	EH	U <sup>6</sup>	UF	UY	VG	VH	Key <sup>5</sup>	M
32	S2	2.98	5.95	1.375	1.96	1.523	5.20	.55	5/16 X 5/16 X 1 13/16	1/2-13 X 1.00
33,33A	S2	3.47	6.94	1.500	2.16	1.674	5.96	.55	3/8 X 3/8 X 2 1/4	5/8-11 X 1.75
34	S2	4.49	8.97	2.000	2.56	2.210	7.44	.79	1/2 X 7/16 X 2 5/8	5/8-11 X 1.75
35	S2	4.83	9.66	2.375	3.54	2.656	8.15	.94	5/8 X 5/8 X 3 5/8	3/4-10 X 2.00

### Output Flange

Gear Frame	Flange Code	AK	AJ	BB	BD	BE	BF
32	5	5.118	6.50	.14	7.87	.39	.47
	6	7.087	8.46	.16	9.84	.47	.55
33,33A	5	7.087	8.46	.16	9.84	.47	.55
	6	9.055	10.43	.16	11.81	.47	.55
34	5	9.055	10.43	.16	11.81	.59	.55
	6	9.842	11.80	.16	13.77	.59	.71
35	5	9.842	11.80	.20	13.77	.71	.71
	6	11.810	13.77	.20	15.75	.71	.71

### C-Face Input

Motor Frame	Gear Frame	AJ1	AK1	BF1	U1	RU	BDX	Key1
56C	32,33A	5.88	4.50	.38	.625	3.33	6.50	3/16 Sq.
	33,34,35	5.88	4.50	.38	.625	3.54	6.50	3/16 Sq.
143TC/145TC	32,33A	5.88	4.50	.38	.875	3.33	6.50	3/16 Sq.
	33,34,35	5.88	4.50	.38	.875	3.54	6.50	3/16 Sq.
182TC/184TC	33,34,35	7.25	8.50	.50	1.125	5.26	9.00	1/4 Sq.

<sup>1</sup> Dimension "D" will never be exceeded, but may vary from values shown. When exact dimensions are required, shims up to .03" may be necessary.

<sup>2</sup> All rough casting dimensions may vary by .25" due to casting variations.

<sup>3</sup> XM dimension when gear frame 33A is used will be 16.42.

<sup>4</sup> Driven shaft entry can be from either side of the gear reducer housing by reversing positioning of the snap rings and washer illustrated.

<sup>5</sup> Output key supplied only on frame 34 in "S2" version.

<sup>6</sup> Output bore tolerances: +.0020", -.0000" for all diameters.

## Combined Finished Bore Hollow Shaft Flange Mount OtN36 - 38

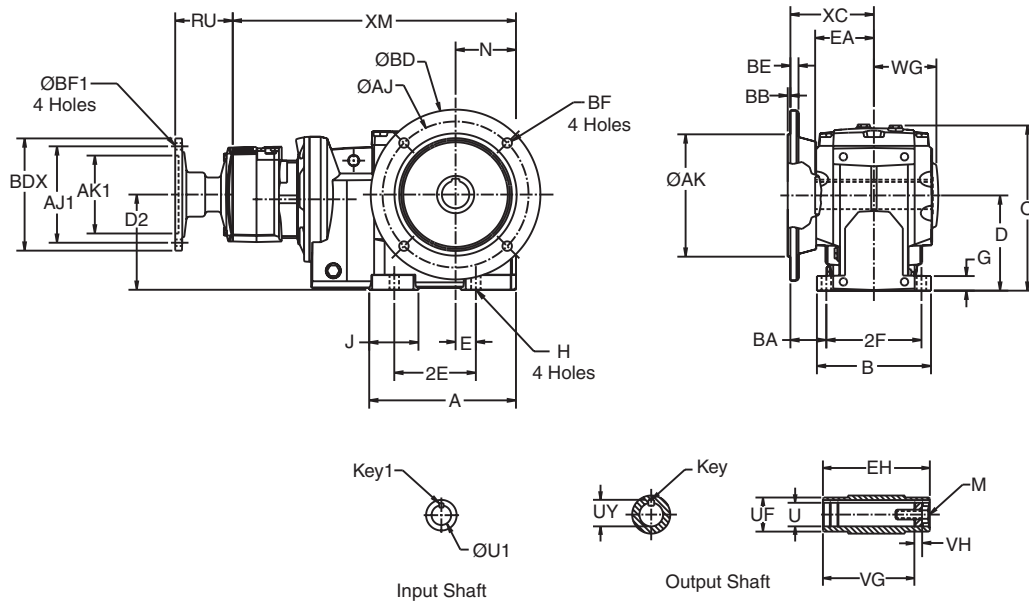

OtN Series

Gear Frame	Version	A	B	D <sup>1</sup>	D2	E	2E	2F	G	H	J	O	N	BA	WG	XC	XM
																	56-215TC
36	S2	17.06	11.41	8.86	8.46	6.99	13.98	9.45	1.57	.87	3.87	16.26	8.74	4.45	6.78	9.17	31.04
37	S2	20.58	12.99	9.84	10.57	8.27	16.54	10.63	1.93	.94	4.78	18.29	10.04	4.45	7.44	9.76	36.37
38	S2	17.85	13.39	14.76	11.48	4.53	13.78	10.63	1.98	1.26	4.06	24.11	8.86	4.65	7.40	9.96	31.94

### Output Shaft

Gear Frame	Version	EA	EH	U <sup>3,4</sup>	UF	UY	VG	VH	Key <sup>5</sup>	M
36	S2	6.22	12.44	2.750	3.93	3.037	10.89	1.23	5/8 X 5/8 X 5 1/2	3/4-10 X 2.00
37	S2	6.80	13.59	3.625	4.72	4.019	11.90	1.23	7/8 X 7/8 X 5 1/2	3/4-10 X 2.00
38	S2	6.81	13.74	4.000	5.50	4.316	11.86	.92	1 X 1 X 6 1/2	1-8 X 2.25

### Output Flange

Gear Frame	Flange Code	AK	AJ	BB	BD	BE	BF
36 & 37	5	13.78	15.75	.236	17.70	.79	.71
	6	17.72	19.68	.236	21.65	.63	.87
38	5	17.72	19.69	.200	21.65	.79	.69
	6	21.65	23.62	.236	25.98	.63	.87

Motor Frame	Gear Frame	AJ1	AK1	BF1	U1	RU	BDX	Key1
56C	All	5.88	4.50	.38	.625	3.54	6.50	3/16 Sq.
143TC/145TC	All	5.88	4.50	.38	.875	3.54	6.50	3/16 Sq.
182TC/184TC	All	7.25	8.50	.50	1.125	5.26	9.00	1/4 Sq.
213TC/215TC	All	7.25	8.50	.50	1.375	5.26	9.00	5/16 Sq.

<sup>1</sup> Dimension "D" will never be exceeded, but may vary from values shown. When exact dimensions are required, shims up to .03" may be necessary.  
<sup>2</sup> All rough casting dimensions may vary by .25" due to casting variations.  
<sup>3</sup> Driven shaft entry can be from either side of the gear reducer housing by reversing positioning of the snap rings and washer illustrated.  
<sup>4</sup> Output bore tolerances: +.0020", -.0000" for all diameters.  
<sup>5</sup> Key not supplied with reducer.

## 2-Stage Bushed Shaft Mount OtN31 - 32

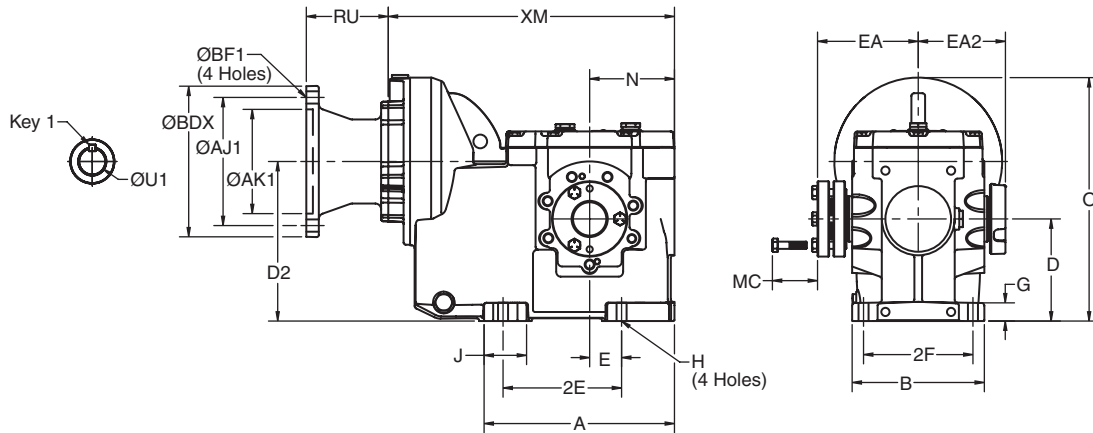

OtN Series

Gear Frame	Version	A	B	D <sup>1</sup>	D2	E	2E	2F	G	H	J	O	N	XM
3132	S2	5.88	4.65	3.15	4.98	1.97	3.94	3.94	.56	.35	1.53	8.01	3.15	10.59
3242	S2	8.22	5.71	4.41	6.89	1.38	5.12	4.72	.79	.43	1.83	10.51	3.66	12.36

### Output Shaft

Gear Frame	Version	EA	EA2	MC <sup>4</sup>	Bushing Bores <sup>3</sup>	
					Min.	Max.
3132	S2	4.25	3.80	1.50	1	1 5/16
3242	S2	4.85	4.27	1.75	1 5/16	1 7/16

Motor Frame	Gear Frame	AJ1	AK1	BF1	U1	RU	BDX	Key1
56C	Any	5.88	4.50	.38	.625	3.54	6.50	3/16 Sq.
143TC/145TC	Any	5.88	4.50	.38	.875	3.54	6.50	3/16 Sq.
182TC/184TC	32	7.25	8.50	.50	1.125	5.26	9.00	1/4 Sq.

<sup>1</sup> Dimension "D" will never be exceeded, but may vary from values shown. When exact dimensions are required, shims up to .03" may be necessary.

<sup>2</sup> All rough casting dimensions may vary by .25" due to casting variations.

<sup>3</sup> Refer to page B-133 by gear frame for listing of all inch and metric bushing bore sizes available.

<sup>4</sup> The MC dimension shows spacing required to install or remove the bushing from the reducer.

<sup>5</sup> Bushing and dust cap can be installed opposite of how they are shown above.

<sup>6</sup> Driven shaft entry can be from either side of the gear reducer housing. Refer to installation manual for requirements.

<sup>7</sup> For details of the torque arm kit, refer to page B-129.

## 3-Stage Taper Bushed Shaft Mount OtN32 - 35

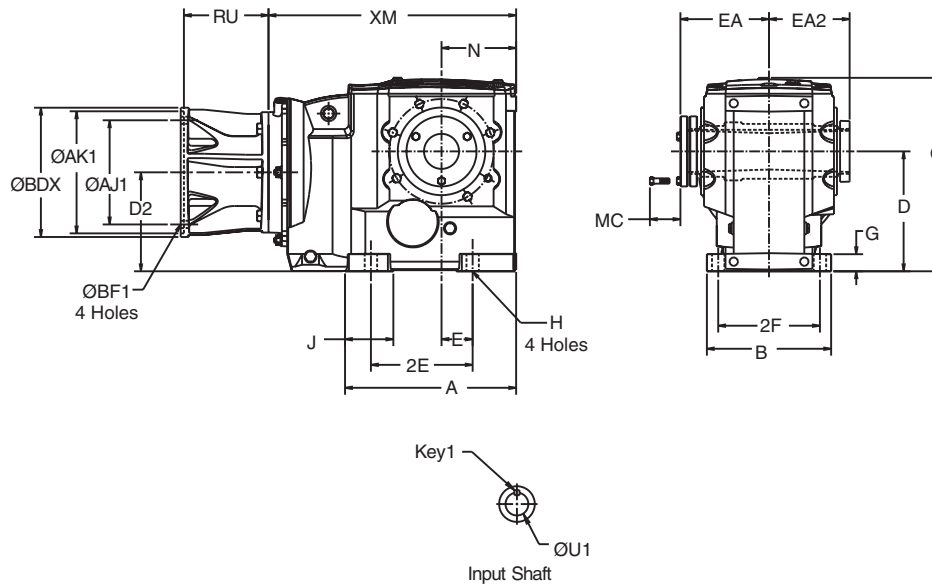

OtN Series

Gear Frame	Version	A	B	D <sup>1</sup>	D2	E	2E	2F	G	H	J	O	N	XM	
														56C-215TC	254TC-286TC
32	S2	7.81	5.71	4.41	3.78	1.38	5.12	4.71	.73	.43	2.34	8.09	3.03	10.98	-
33 (A)	S2	8.50	6.61	5.51	5.24	1.18	4.72	5.51	.85	.55	2.86	9.69	3.54	12.90	-
34	S2	10.13	7.87	7.09	5.90	1.57	5.91	6.50	1.07	.71	2.67	12.05	4.49	14.56	-
35	S2	11.92	8.66	8.35	6.89	2.17	7.09	7.09	1.18	.87	3.45	13.58	5.20	16.90	17.25

### Output Shaft

Gear Frame	Version	EA	EA2	MC <sup>4</sup>	Bushing Bores <sup>3</sup>	
					Min.	Max.
32	S2	4.85	4.27	1.75	1 5/16	1 7/16
33	S2	4.82	4.23	1.75	1 5/16	1 7/16
33A	S2	5.76	5.18	1.88	1 7/16	1 15/16
34	S2	5.84	5.27	1.88	1 11/16	1 15/16
35	S2	6.17	5.620	1.88	2	2 7/16

### C-Face Input

Motor Frame	Gear Frame	AJ1	AK1	BF1	U1	RU	BDX	Key1
56C	Any	5.88	4.50	.38	.625	3.54	6.50	3/16 Sq.
143TC/145TC	Any	5.88	4.50	.38	.875	3.54	6.50	3/16 Sq.
182TC/184TC	Any	7.25	8.50	.50	1.125	5.26	9.00	1/4 Sq.
213TC/215TC	33,34,35	7.25	8.50	.50	1.375	5.26	9.00	5/16 Sq.
254TC/256TC	35	7.25	8.50	.50	1.625	6.12	9.00	3/8 Sq.
284TC/286TC	35	9.00	10.50	.50	1.875	7.09	11.25	1/2 Sq.

<sup>1</sup> Dimension "D" will never be exceeded, but may vary from values shown. When exact dimensions are required, shims up to .03" may be necessary.

<sup>2</sup> All rough casting dimensions may vary by .25" due to casting variations.

<sup>3</sup> Refer to page B-133 by gear frame for listing of all inch and metric bushing bore sizes available.

<sup>4</sup> The MC dimension shows spacing required to install or remove the

bushing from the reducer.

<sup>5</sup> Bushing and dust cap can be installed opposite of how they are shown above.

<sup>6</sup> Driven shaft entry can be from either side of the gear reducer housing. Refer to installation manual for requirements.

<sup>7</sup> For details of the torque arm kit, refer to page B-129.



## 3-Stage Taper Bushed Shaft Mount OtN36 - 38

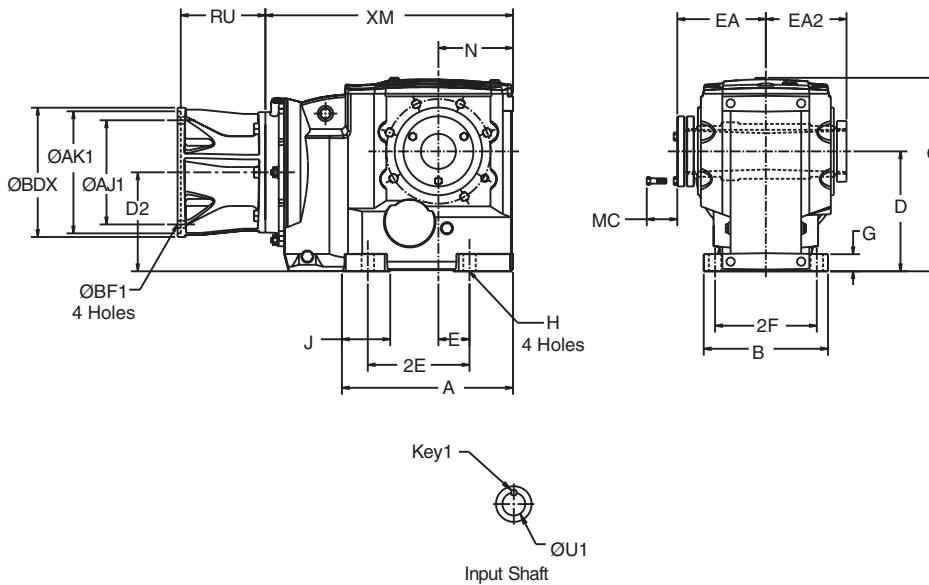

OtN Series

Gear Frame	Version	A	B	D <sup>1</sup>	D2	E	2E	2F	G	H	J	O	N	XM	
														182-215TC	254-365TC
36	S2	17.06	11.41	8.86	8.86	6.99	13.98	9.45	1.57	.87	3.87	16.26	8.74	23.38	23.73
37	S2	20.58	12.99	9.84	10.98	8.27	16.54	10.63	1.93	.94	4.78	18.29	10.04	23.38	29.06
38	S2	17.85	13.39	14.76	11.87	4.53	13.78	10.63	1.98	1.26	4.06	24.11	8.86	24.29	24.64

### Output Shaft

Gear Frame	Version	EA	EA2	MC <sup>4</sup>	Bushing Bores <sup>3</sup>	
					Min.	Max.
36	S2	6.81	7.83	1.88	2 7/16	2 15/16
37	S2	9.50	8.86	2.25	2 7/8	3 7/16
38	S2	8.66	8.08	2.75	2 15/16	3 15/16

Motor Frame	Gear Frame	AJ1	AK1	BF1	U1	RU	BDX	Key1
182TC/184TC	36, 37	7.25	8.50	.50	1.125	5.26	9.00	1/4 Sq.
213TC/215TC	All	7.25	8.50	.50	1.375	5.26	9.00	5/16 Sq.
254TC/256TC	All	7.25	8.50	.50	1.625	6.12	9.00	3/8 Sq.
284TC/286TC	All	9.00	10.50	.50	1.875	7.09	11.25	1/2 Sq.
324TC/326TC	All	11.00	12.50	.625	2.125 <sup>5</sup>	8.45	13.38	1/2 Sq.
364TC/365TC	37, 38	11.00	12.50	.625	2.375 <sup>5</sup>	8.45	13.38	5/8 Sq.

<sup>1</sup> Dimension "D" will never be exceeded, but may vary from values shown. When exact dimensions are required, shims up to .03" may be necessary.

<sup>2</sup> All rough casting dimensions may vary by .25" due to casting variations.

<sup>3</sup> Refer to page B-133 by gear frame for listing of all inch and metric bushing bore sizes available.

<sup>4</sup> The MC dimension shows spacing required to install or remove the bushing from the reducer.

<sup>5</sup> Bushing and dust cap can be installed opposite of how they are shown above.

<sup>6</sup> Driven shaft entry can be from either side of the gear reducer housing. Refer to installation manual for requirements.

<sup>7</sup> For details of the torque arm kit, refer to pages B-129 and B-130.

<sup>8</sup> These frames utilize coupling input. This is input bore for coupling provided.

## Combined Taper Bushed Shaft Mount OtN32 - 35

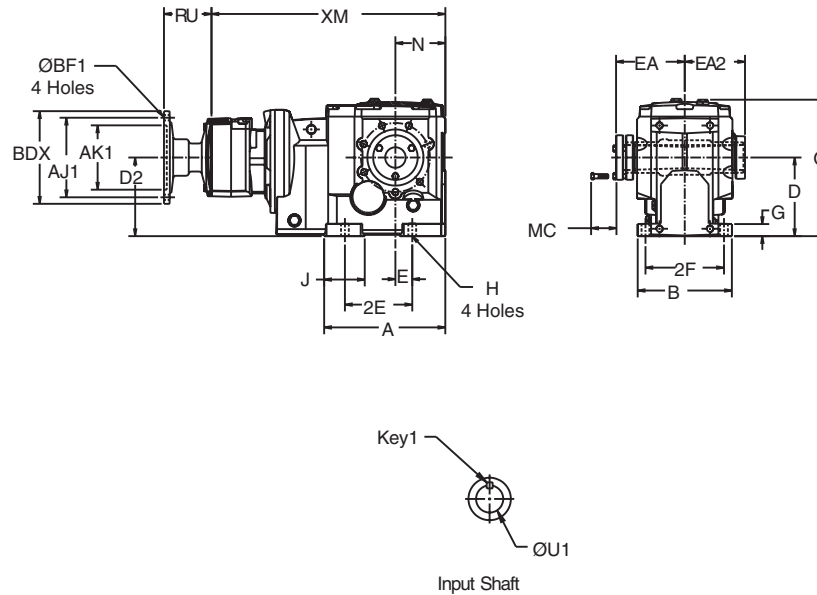

OtN Series

Gear Frame	Version	A	B	D <sup>1</sup>	D <sub>2</sub>	E	2E	2F	G	H	J	O	N	XM
32	S2	7.81	5.71	4.41	4.06	1.38	5.12	4.71	.73	.43	2.34	8.09	3.03	14.49
33, 33A	S2	8.50	6.61	5.51	4.91	1.18	4.72	5.51	.85	.55	2.86	9.69	3.54	19.90 <sup>8</sup>
34	S2	10.13	7.87	7.09	5.57	1.57	5.91	6.50	1.07	.71	2.67	12.05	4.49	21.55
35	S2	11.92	8.66	8.35	6.56	2.17	7.09	7.09	1.18	.87	3.45	13.58	5.20	23.87

### Output Shaft

Gear Frame	Version	EA	EA <sub>2</sub>	MC <sup>4</sup>	Bushing Bores <sup>3</sup>	
					Min.	Max.
32	S2	4.85	4.27	1.75	1 5/16	1 7/16
33	S2	4.82	4.23	1.75	1 5/16	1 7/16
33A	S2	5.76	5.18	1.88	1 7/16	1 15/16
34	S2	5.84	5.27	1.88	1 11/16	1 15/16
35	S2	6.17	5.620	1.88	2	2 7/16

### C-Face Input

Motor Frame	Gear Frame	AJ1	AK1	BF1	U1	RU	BDX	Key1
56C	32, 33A	5.88	4.50	.38	.625	3.33	6.50	3/16 Sq.
	33,34,35	5.88	4.50	.38	.625	3.54	6.50	3/16 Sq.
143TC/145TC	32, 33A	5.88	4.50	.38	.825	3.33	6.50	3/16 Sq.
	33,34,35	5.88	4.50	.38	.875	3.54	6.50	3/16 Sq.
182TC/184TC	33,34,35	7.25	8.50	.50	1.125	5.26	9.00	1/4 Sq.

<sup>1</sup> Dimension "D" will never be exceeded, but may vary from values shown. When exact dimensions are required, shims up to .03" may be necessary.

<sup>2</sup> All rough casting dimensions may vary by .25" due to casting variations.

<sup>3</sup> Refer to page B-133 by gear frame for listing of all inch and metric bushing bore sizes available.

<sup>4</sup> The MC dimension shows spacing required to install or remove the

bushing from the reducer.

<sup>5</sup> Bushing and dust cap can be installed opposite of how they are shown above.

<sup>6</sup> Driven shaft entry can be from either side of the gear reducer housing. Refer to installation manual for requirements.

<sup>7</sup> For details of the torque arm kit, refer to page B-129.

<sup>8</sup> XM dimension when gear frame 33A is used will be 16.42.

## Combined Taper Bushed Shaft Mount OtN36 - 38

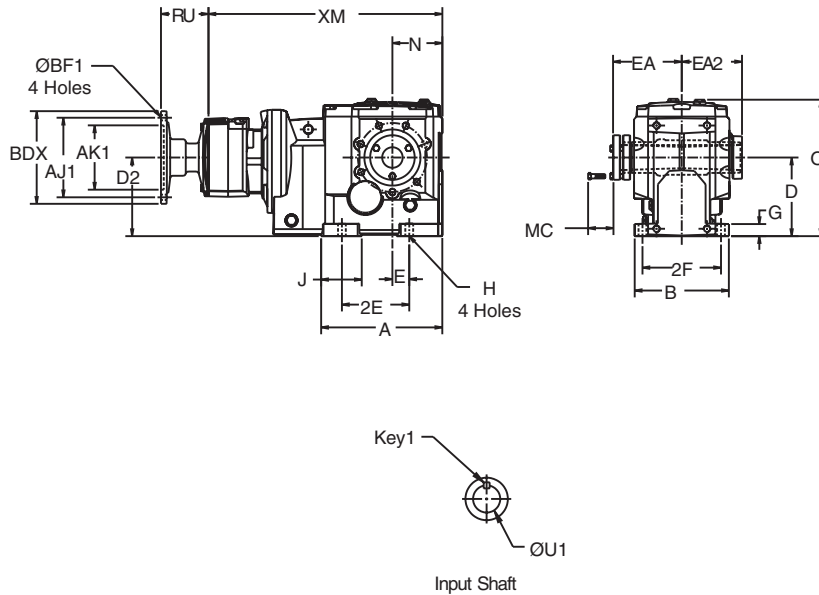

Gear Frame	Version	A	B	D <sup>1</sup>	D2	E	2E	2F	G	H	J	O	N	XM
														56-215TC
36	S2	17.06	11.41	8.86	8.46	6.99	13.98	9.45	1.57	.87	3.87	16.26	8.74	31.04
37	S2	20.58	12.99	9.84	10.57	8.27	16.54	10.63	1.93	.94	4.78	18.29	10.04	36.37
38	S2	17.85	13.39	14.76	11.48	4.53	13.78	10.63	1.98	1.26	4.06	24.11	8.86	31.94

### Output Shaft

Gear Frame	Version	EA	EA2	MC <sup>4</sup>	Bushing Bores <sup>3</sup>	
					Min.	Max.
36	S2	6.81	7.83	1.88	2 7/16	2 15/16
37	S2	9.50	8.86	2.25	2 7/8	3 7/16
38	S2	8.66	8.08	2.75	2 15/16	3 15/16

Motor Frame	Gear Frame	AJ1	AK1	BF1	U1	RU	BDX	Key1
56C	All	5.88	4.50	.38	.625	3.54	6.50	3/16 Sq.
143TC/145TC	All	5.88	4.50	.38	.875	3.54	6.50	3/16 Sq.
182TC/184TC	All	7.25	8.50	.50	1.125	5.26	9.00	1/4 Sq.
213TC/215TC	All	7.25	8.50	.50	1.375	5.26	9.00	5/16 Sq.

<sup>1</sup> Dimension "D" will never be exceeded, but may vary from values shown. When exact dimensions are required, shims up to .03" may be necessary.  
<sup>2</sup> All rough casting dimensions may vary by .25" due to casting variations.  
<sup>3</sup> Refer to page B-133 by gear frame for listing of all inch and metric bushing bore sizes available.  
<sup>4</sup> The MC dimension shows spacing required to install or remove the bushing from the reducer.

<sup>5</sup> Bushing and dust cap can be installed opposite of how they are shown above.  
<sup>6</sup> Driven shaft entry can be from either side of the gear reducer housing. Refer to installation manual for requirements.  
<sup>7</sup> For details of the torque arm kit, refer to pages B-129 and B-130.  
<sup>8</sup> XM dimension when gear frame 33A is used will be 16.42.

## 2-Stage CEMA Screw Conveyor Drive OtN32

Standard conduit box location will be F1 unless specified otherwise.

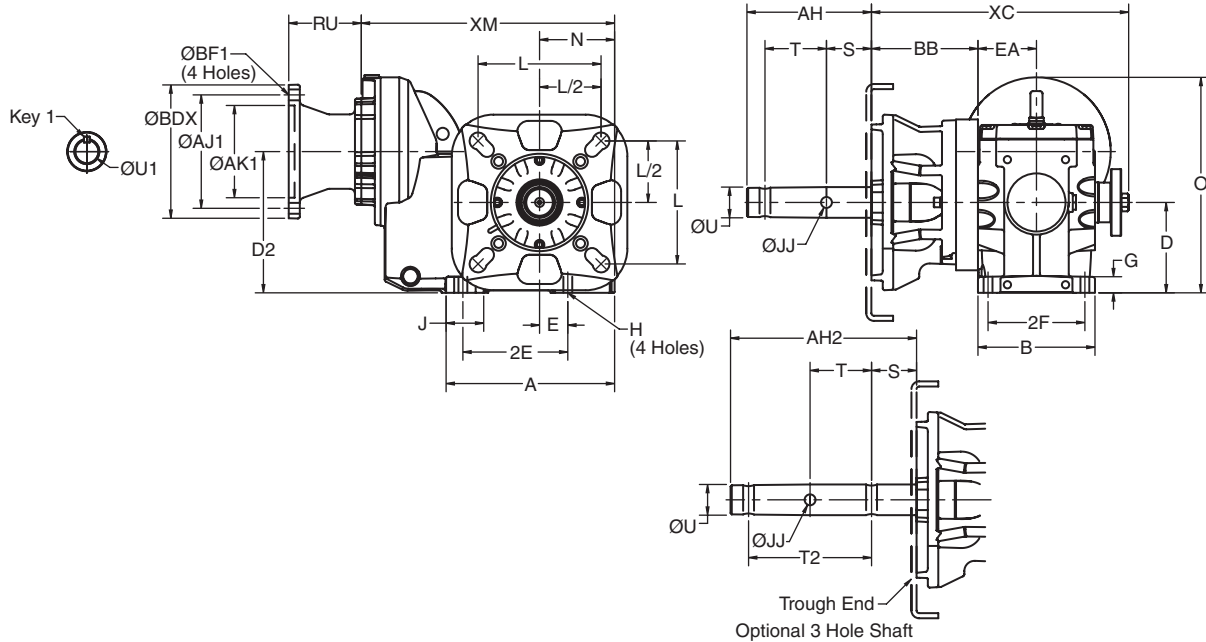

OtN Series

Gear Frame	Version	A	B	D'	D2	E	2E	2F	G	H	J	O	N	EA	XC	XM
3242	S2	8.22	5.71	4.41	6.89	1.38	5.12	4.72	.79	.43	1.83	10.51	3.66	2.85	7.35	12.36

### Output Shaft

Gear Frame	Screw Dia.	JJ	L	U	S	T	T2	AH	AH2	BB
3242	6-10	.53	4.00	1.50	2.13	3.00	6.00	6.00	9.00	5.13
	9-12	.66	5.13	2.00	2.13	3.00	6.00	6.00	9.00	5.13
	12-14	.66	5.63	2.44	2.75	3.00	6.00	6.00	9.69	5.13
	12-20	.78	6.00	3.00	2.88	3.00	6.00	6.88	9.88	5.13

Motor Frame	Gear Frame	AJ1	AK1	BF1	U1	RU	BDX	Key1
56C	32	5.88	4.50	.38	.625	3.54	6.50	3/16 Sq.
143TC/145TC	32	5.88	4.50	.38	.875	3.54	6.50	3/16 Sq.
182TC/184TC	32	7.25	8.50	.50	1.125	5.26	9.00	1/4 Sq.

<sup>1</sup> Dimension "D" will never be exceeded, but may vary from values shown. When exact dimensions are required, shims up to .03" may be necessary.

<sup>2</sup> All rough casting dimensions may vary by .25" due to casting variations.

<sup>3</sup> Refer to pages B-131 and B-132 for the screw conveyor drive shafts, trough ends and other accessories available for each gear frame size.

<sup>4</sup> Thrust ratings for each gear frame size are listed on page B-131.

## 3-Stage CEMA Screw Conveyor Drive OtN32 - 35

Standard conduit box location will be F1 unless specified otherwise.

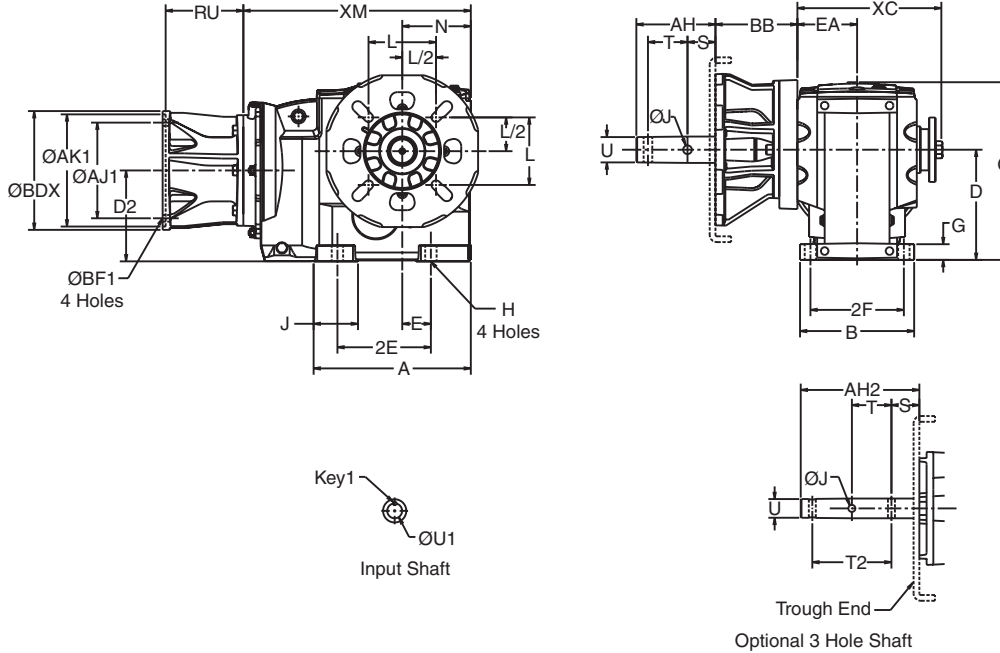

OtN Series

Gear Frame	Version	A	B	D <sup>1</sup>	D2	E	2E	2F	G	H	J	O	N	EA	XC	XM	
																56C-215TC	254TC-286TC
32	S2	7.81	5.71	4.41	3.78	1.38	5.12	4.71	.73	.43	2.34	8.09	3.03	2.85	7.35	10.98	-
33	S2	8.50	6.61	5.51	5.24	1.18	4.72	5.51	.85	.55	2.86	9.69	3.54	3.35	8.30	12.90	-
34	S2	10.13	7.87	7.09	5.90	1.57	5.91	6.50	1.07	.71	2.67	12.05	4.49	4.07	9.84	14.56	-
35	S2	11.92	8.66	8.35	6.89	2.17	7.09	7.09	1.18	.87	3.37	13.58	5.20	4.43	11.00	16.90	17.25

### Screw Conveyor

Gear Frame	Screw Dia.	J	L	U	S	T	T2	AH	AH2	BB
32, 33	6 - 10	.53	4.00	1.50	2.13	3.00	6.00	6.00	9.00	5.13
	9 - 12	.66	5.13	2.00	2.13	3.00	6.00	6.00	9.00	5.13
	12 - 14	.66	5.63	2.44	2.75	3.00	6.00	6.00	9.69	5.13
	12 - 20	.78	6.00	3.00	2.88	3.00	6.00	6.88	9.88	5.13
34	6 - 10	.53	4.00	1.50	2.13	3.00	6.00	6.00	9.00	5.13
	9 - 12	.66	5.13	2.00	2.13	3.00	6.00	6.00	9.00	5.13
	12 - 14	.66	5.63	2.44	2.75	3.00	6.00	6.00	9.69	5.13
	12 - 20	.78	6.00	3.00	2.88	3.00	6.00	6.88	9.88	5.13
35	9 - 12	.66	5.13	2.00	2.13	3.00	6.00	6.00	9.00	6.21
	12 - 14	.66	5.63	2.44	2.75	3.00	6.00	6.69	9.69	6.21
	12 - 20	.78	6.00	3.00	2.88	3.00	6.00	6.88	9.88	6.21
	18 - 24	.91	6.75	3.44	3.88	4.00	-	9.13	-	6.21

Motor Frame	Gear Frame	AJ1	AK1	BF1	U1	RU	BDX	Key1
56C	Any	5.88	4.50	.38	.625	3.54	6.50	3/16 Sq.
143TC/145TC	Any	5.88	4.50	.38	.875	3.54	6.50	3/16 Sq.
182TC/184TC	Any	7.25	8.50	.50	1.125	5.26	9.00	1/4 Sq.
213TC/215TC	33, 34, 35	7.25	8.50	.50	1.375	5.26	9.00	5/16 Sq.
254TC/256TC	35	7.25	8.50	.50	1.625	6.12	9.00	3/8 Sq.
284TC/286TC	35	9.00	10.50	.50	1.875	7.09	11.25	1/2 Sq.

<sup>1</sup> Dimension "D" will never be exceeded, but may vary from values shown. When exact dimensions are required, shims up to .03" may be necessary.

<sup>2</sup> All rough casting dimensions may vary by .25" due to casting variations.

<sup>3</sup> Refer to pages B-131 and B-132 for the screw conveyor drive shafts, trough ends and other accessories available for each gear frame size.

<sup>4</sup> Thrust ratings for each gear frame size are listed on page B-131.

## 3-Stage CEMA Screw Conveyor Drive OtN36 - 37

Standard conduit box location will be F1 unless specified otherwise.

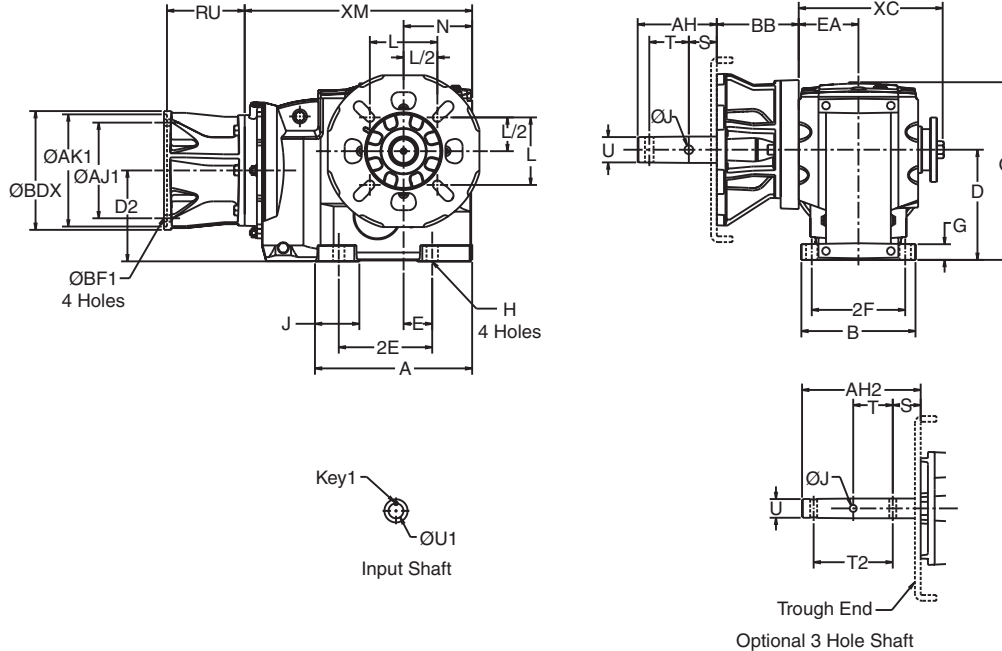

OtN Series

Gear Frame	Version	A	B	D <sup>1</sup>	D2	E	2E	2F	G	H	J	O	N	EA	XC	XM	
																182-215TC	254-365TC
36	S2	17.06	11.41	8.86	8.86	6.99	13.98	9.45	1.57	.87	3.87	16.26	8.74	6.02	13.14	23.38	23.73
37	S2	20.58	12.99	9.84	10.98	8.27	16.54	10.63	1.93	.94	4.78	18.29	10.04	6.61	14.76	23.38	29.06

### Screw Conveyor

Gear Frame	Screw Dia.	JJ	L	U	S	T	T2	AH	AH2	BB
36	9-12	.66	5.13	2.00	2.13	3.00	6.00	6.00	9.00	6.67
	12, 14	.66	5.63	2.44	2.75	3.00	6.00	6.69	9.69	6.67
	12-20	.78	6.00	3.00	2.88	3.00	6.00	6.88	9.88	6.67
	18-24	.91	6.75	3.44	3.88	4.00	8.00	9.13	13.13	6.67
37	12-20	.78	6.00	3.00	2.88	3.00	6.00	6.88	9.88	7.94
	18-24	.91	6.75	3.44	3.88	4.00	8.00	9.13	13.13	7.94

Motor Frame	Gear Frame	AJ1	AK1	BF1	U1	RU	BDX	Key1
182TC/184TC	All	7.25	8.50	.50	1.125	5.26	9.00	1/4 Sq.
213TC/215TC	All	7.25	8.50	.50	1.375	5.26	9.00	5/16 Sq.
254TC/256TC	All	7.25	8.50	.50	1.625	6.12	9.00	3/8 Sq.
284TC/286TC	All	9.00	10.50	.50	1.875	7.09	11.25	1/2 Sq.
324TC/326TC	All	11.00	12.50	.625	2.125 <sup>5</sup>	8.45	13.38	1/2 Sq.
364TC/365TC	All	11.00	12.50	.625	2.375 <sup>5</sup>	8.45	13.38	5/8 Sq.

<sup>1</sup> Dimension "D" will never be exceeded, but may vary from values shown. When exact dimensions are required, shims up to .03" may be necessary.

<sup>2</sup> All rough casting dimensions may vary by .25" due to casting variations.

<sup>3</sup> Refer to pages B-131 and B-132 for the screw conveyor drive shafts, trough ends and other accessories available for each gear frame size.

<sup>4</sup> Thrust ratings for each gear frame size are listed on page B-131.

<sup>5</sup> Frame 36 and 37 utilize coupling input. This is input bore for coupling provided.

## Combined CEMA Screw Conveyor Drive OtN32 - 35

Standard conduit box location will be F1 unless specified otherwise.

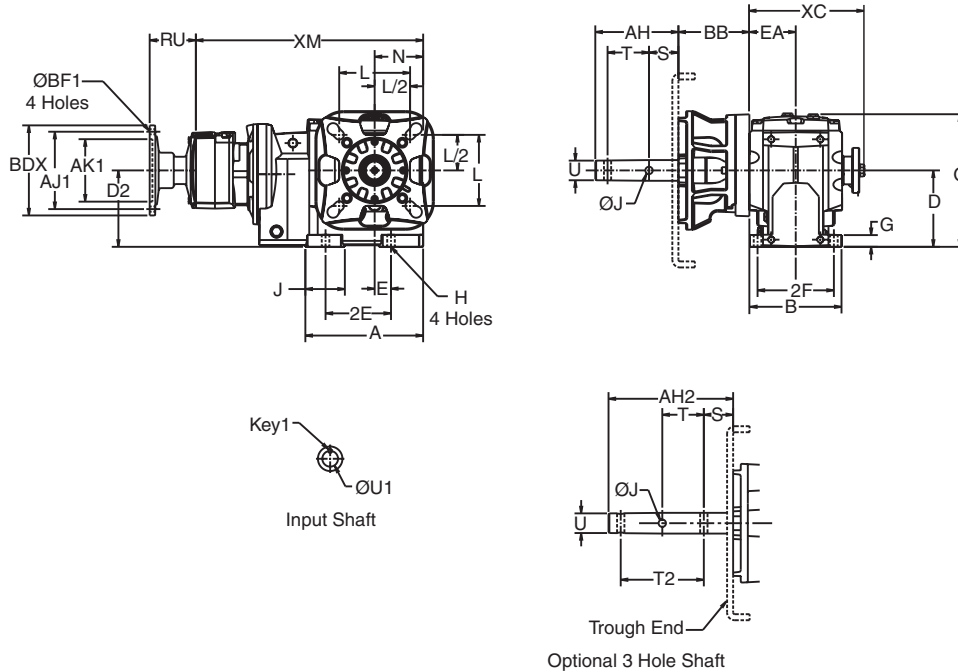

Gear Frame	Version	A	B	D <sup>1</sup>	D <sub>2</sub>	E	2E	2F	G	H	J	O	N	EA	XC	XM
32	S2	7.81	5.71	4.41	4.06	1.38	5.12	4.71	.73	.43	2.34	8.09	3.03	2.85	7.35	14.49
33, 33A	S2	8.50	6.61	5.51	4.91	1.18	4.72	5.51	.85	.55	2.86	9.69	3.54	3.35	8.30	19.90 <sup>5</sup>
34	S2	10.13	7.87	7.09	5.57	1.57	5.91	6.50	1.07	.71	2.67	12.05	4.49	4.07	9.84	21.55
35	S2	11.92	8.66	8.35	6.56	2.17	7.09	7.09	1.18	.87	3.37	13.58	5.20	4.43	11.00	23.87

### Screw Conveyor

Gear Frame	Screw Dia.	J	L	U	S	T	T2	AH	AH2	BB
32, 33, 33A	6 - 10	.53	4.00	1.50	2.13	3.00	6.00	6.00	9.00	5.13
	9 - 12	.66	5.13	2.00	2.13	3.00	6.00	6.00	9.00	5.13
	12 - 14	.66	5.63	2.44	2.75	3.00	6.00	6.00	9.69	5.13
	12 - 20	.78	6.00	3.00	2.88	3.00	6.00	6.88	9.88	5.13
34	6 - 10	.53	4.00	1.50	2.13	3.00	6.00	6.00	9.00	5.13
	9 - 12	.66	5.13	2.00	2.13	3.00	6.00	6.00	9.00	5.13
	12 - 14	.66	5.63	2.44	2.75	3.00	6.00	6.00	9.69	5.13
	12 - 20	.78	6.00	3.00	2.88	3.00	6.00	6.88	9.88	5.13
35	9 - 12	.66	5.13	2.00	2.13	3.00	6.00	6.00	9.00	6.21
	12 - 14	.66	5.63	2.44	2.75	3.00	6.00	6.69	9.69	6.21
	12 - 20	.78	6.00	3.00	2.88	3.00	6.00	6.88	9.88	6.21
	18 - 24	.91	6.75	3.44	3.88	4.00	-	9.13	-	6.21

Motor Frame	Gear Frame	AJ1	AK1	BF1	U1	RU	BDX	Key1
56C	32, 33A	5.88	4.50	.38	.625	3.33	6.50	3/16 Sq.
	33, 34, 35	5.88	4.50	.38	.625	3.54	6.50	3/16 Sq.
143TC/145TC	32, 33A	5.88	4.50	.38	.875	3.33	6.50	3/16 Sq.
	33, 34, 35	5.88	4.50	.38	.875	3.54	6.50	3/16 Sq.
182TC/184TC	33, 34, 35	7.25	8.50	.50	1.125	5.26	9.00	1/4 Sq.

<sup>1</sup> Dimension "D" will never be exceeded, but may vary from values shown. When exact dimensions are required, shims up to .03" may be necessary.

<sup>2</sup> All rough casting dimensions may vary by .25" due to casting variations.

<sup>3</sup> Refer to pages B-131 and B-132 for the screw conveyor drive shafts, trough ends and other accessories available for each gear frame size.

<sup>4</sup> Thrust ratings for each gear frame size are listed on page B-131.

<sup>5</sup> XM dimension is 16.42 for gear frame 33A.



## Combined CEMA Screw Conveyor Drive OtN36 - 37

Standard conduit box location will be F1 unless specified otherwise.

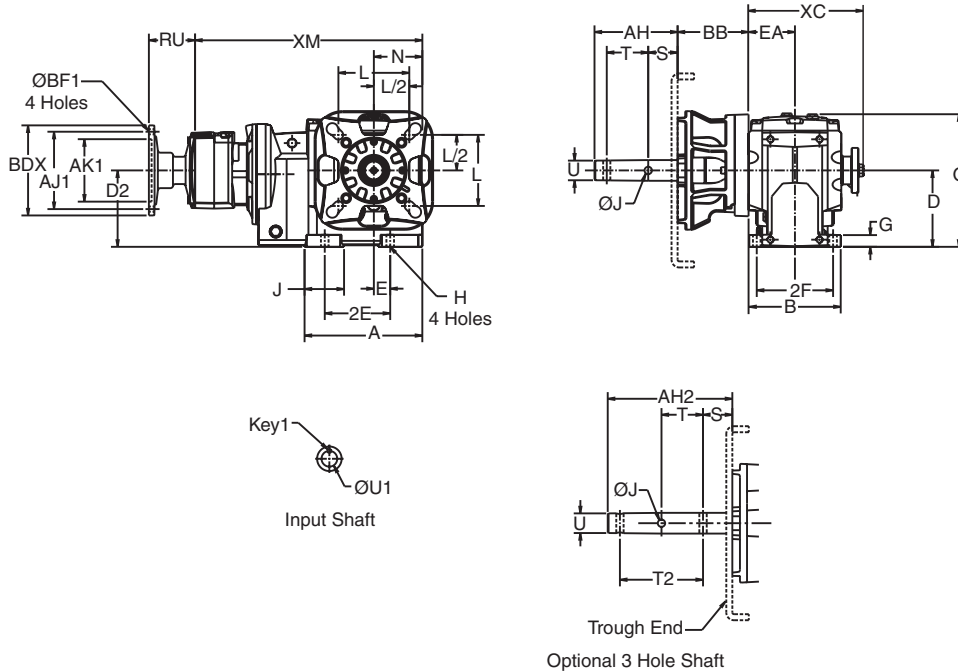

OtN Series

Gear Frame	Version	A	B	D <sup>1</sup>	D2	E	2E	2F	G	H	J	O	N	EA	XC	XM
																56-215TC
36	S2	17.06	11.41	8.86	8.46	6.99	13.98	9.45	1.57	.87	3.87	16.26	8.74	6.02	13.14	31.04
37	S2	20.58	12.99	9.84	10.57	8.27	16.54	10.63	1.93	.94	4.78	18.29	10.04	6.61	14.76	36.37

### Screw Conveyor

Gear Frame	Screw Dia.	JJ	L	U	S	T	T2	AH	AH2	BB
36	9-12	.66	5.13	2.00	2.13	3.00	6.00	6.00	9.00	6.67
	12, 14	.66	5.63	2.44	2.75	3.00	6.00	6.69	9.69	6.67
	12-20	.78	6.00	3.00	2.88	3.00	6.00	6.88	9.88	6.67
	18-24	.91	6.75	3.44	3.88	4.00	8.00	9.13	13.13	6.67
37	12-20	.78	6.00	3.00	2.88	3.00	6.00	6.88	9.88	7.94
	18-24	.91	6.75	3.44	3.88	4.00	8.00	9.13	13.13	7.94

Motor Frame	Gear Frame	AJ1	AK1	BF1	U1	RU	BDX	Key1
56C	All	5.88	4.50	.38	.625	3.54	6.50	3/16 Sq.
143TC/145TC	All	5.88	4.50	.38	.875	3.54	6.50	3/16 Sq.
182TC/184TC	All	7.25	8.50	.50	1.125	5.26	9.00	1/4 Sq.
213TC/215TC	All	7.25	8.50	.50	1.375	5.26	9.00	5/16 Sq.

<sup>1</sup> Dimension "D" will never be exceeded, but may vary from values shown. When exact dimensions are required, shims up to .03" may be necessary.

<sup>2</sup> All rough casting dimensions may vary by .25" due to casting variations.

<sup>3</sup> Refer to pages B-131 and B-132 for the screw conveyor drive shafts, trough ends and other accessories available for each gear frame size.

<sup>4</sup> Thrust ratings for each gear frame size are listed on page B-131.

## 2-Stage Output Shafted Foot Mount OtN31 - 32

OtN Series

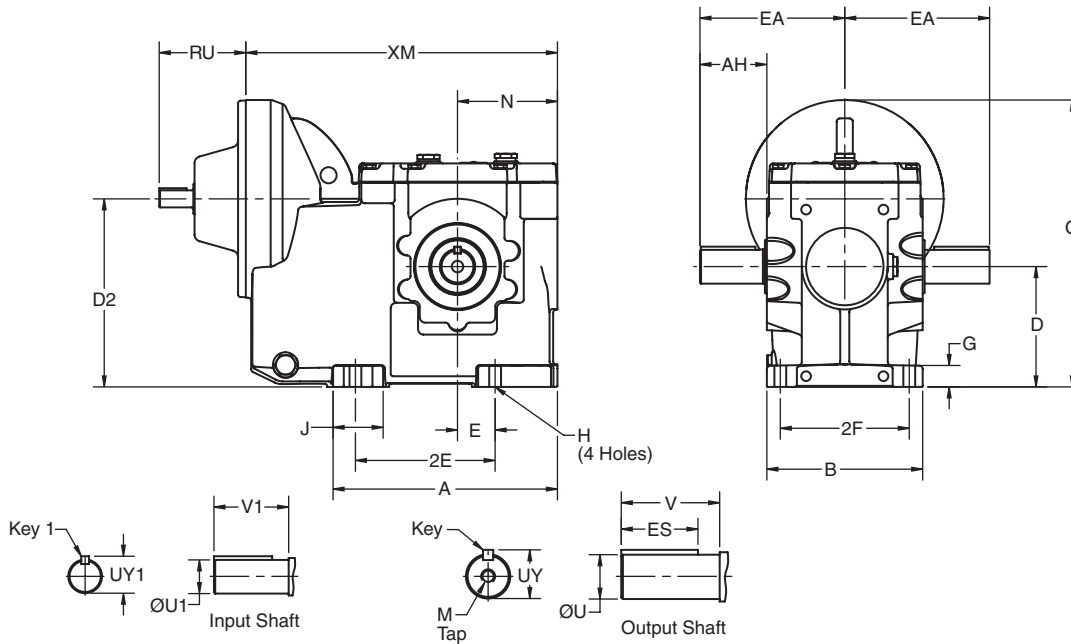

Gear Frame	Version	A	B	D <sup>1</sup>	D2	E	2E	2F	G	H	J	O	N	XM
3132	S2	5.88	4.65	3.15	4.98	1.97	3.94	3.94	.56	.35	1.53	8.01	3.15	10.59
3242	S2	8.22	5.71	4.41	6.89	1.38	5.12	4.72	.79	.43	1.83	10.51	3.66	12.36

### Output Shaft

Gear Frame	Version	U <sup>3</sup>	UY	V	AH	EA	Key	ES	M
3132	S2	1.000	1.10	1.77	1.83	4.33	1/4 Sq.	1.34	3/8-16 X .87
3242	S2	1.250	1.35	2.38	2.45	5.31	1/4 Sq.	2.03	1/2-13 X 1.12

### Input Shaft

Gear Frame	Version	RU	U1 <sup>4</sup>	UY1	V1	Key1
31	S2	3.17	.625	.705	1.25	3/16 Sq.
32	S2	3.17	.625	.705	1.25	3/16 Sq.

<sup>1</sup> Dimension "D" will never be exceeded, but may vary from values shown. When exact dimensions are required, shims up to .03" may be necessary.

<sup>2</sup> All rough casting dimensions may vary by .25" due to casting variations.

<sup>3</sup> Output shaft extension tolerances: +.0000"; -.0005" for shafts up to 1.5" diameter "U". Larger diameter "U", +.000"; -.001".

<sup>4</sup> Input shaft extension tolerances: +.0000"; -.0005" up to 1.5" diameter. Larger diameter "U1", +.000"; -.001".

## 3-Stage Output Shafted Foot Mount OtN32 - 38

OtN Series

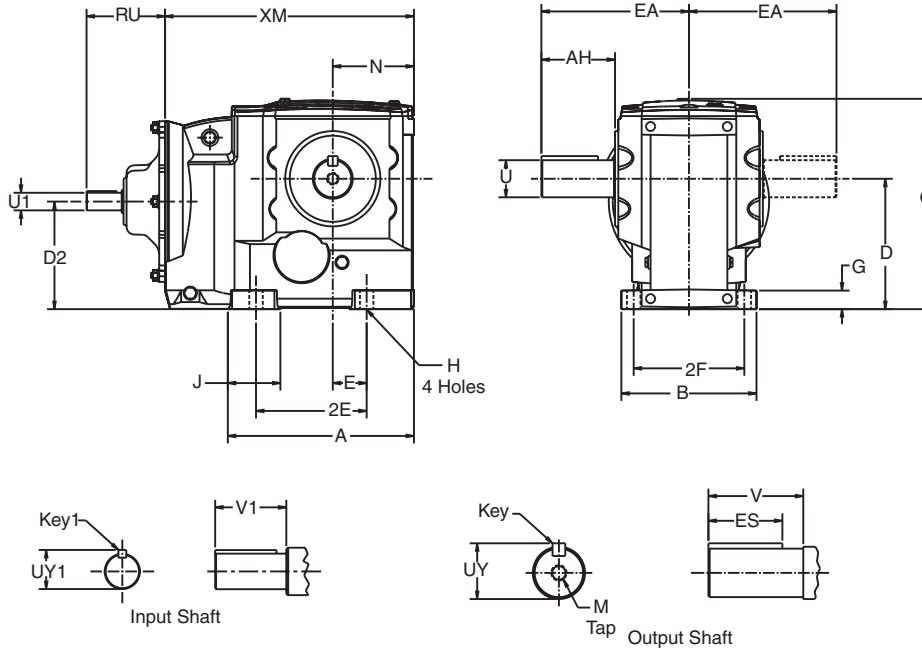

Gear Frame	Version	A	B	D <sup>1</sup>	D2	E	2E	2F	G	H	J	O	N	XM
32	S2	7.81	5.71	4.41	3.78	1.38	5.12	4.72	.73	.43	3.87	8.09	3.03	10.04
	S1	8.50	6.61	5.51	5.24	1.18	4.72	5.51	.85	.55	2.86	9.69	3.54	11.97
33	S2	8.08	8.58	4.92	5.20	3.35	6.69	6.10	.79	.55	2.27	10.43	3.54	11.97
	S1	10.13	7.87	7.09	5.90	1.57	5.91	6.50	1.07	.71	2.67	12.05	4.49	13.78
34	S2	10.69	9.60	6.30	7.49	4.53	9.06	7.68	1.18	.71	3.19	13.39	4.49	13.78
	S1	11.92	8.66	8.35	6.89	2.17	7.09	7.09	1.18	.87	3.37	13.58	5.20	15.95
35	S2	13.07	10.98	7.87	9.33	5.51	11.02	9.06	1.40	.87	4.05	16.22	5.20	15.95
	S1	17.06	11.41	8.86	8.86	6.99	13.98	9.45	1.57	.87	3.87	16.26	8.74	23.11
36	S1	20.58	12.99	9.84	10.98	8.27	16.54	10.63	1.93	.94	4.78	18.29	10.04	28.44
37	S1	17.85	13.39	14.76	11.87	4.53	13.78	10.63	1.98	1.26	4.06	24.11	8.86	24.02

### Output Shaft

Gear Frame	Version	U <sup>3</sup>	UY	V	AH	EA	Key	ES	M
32	S2	1.250	1.354	2.36	2.46	5.31	1/4 Sq.	2.06	1/2 -13 x 1.12
	S1	1.625	1.783	3.25	3.39	6.73	3/8 Sq.	2.78	5/8 -11 x 1.38
33	S2	1.500	1.657	3.18	3.19	7.12	3/8 Sq.	2.78	5/8 -11 x 1.38
	S1	2.000	2.210	3.63	3.76	8.11	1/2 Sq.	3.06	3/4 -10 x 1.61
34	S2	1.750	1.909	3.56	3.66	8.46	3/8 Sq.	3.56	3/4 -10 x 1.61
	S1	2.375	2.638	4.61	4.74	9.45	5/8 Sq.	3.81	3/4 -10 x 1.61
35	S2	2.375	2.638	5.73	5.27	10.57	5/8 Sq.	4.81	3/4 -10 x 1.61
	S1	2.875	3.20	5.75	5.92	11.94	3/4 Sq.	5.00	3/4 -10 x 1.61
36	S1	3.625	4.01	6.86	7.04	13.66	7/8 Sq.	6.00	1-8 x 2.13
37	S1	4.375	4.809	8.99	9.97	17.03	1.00 Sq.	7.00	1-8 X 2.25

### Input Shaft

Gear Frame	Version	RU	U1 <sup>4</sup>	UY1	V1	Key1
32	S2	3.17	.625	.705	1.25	3/16 Sq.
33	S1, S2	3.17	.625	.705	1.25	3/16 Sq.
	S1, S2	4.75	1.125	1.236	2.25	1/14 Sq.
34	S1, S2	5.03	1.125	1.236	2.25	1/14 Sq.
35	S1, S2	7.56	1.875	2.101	3.75	1/2 Sq.
36	S1	7.56	1.875	2.101	3.75	1/2 Sq.
37	S1	7.56	1.875	2.101	3.75	1/2 Sq.
38	S2	7.56	1.875	2.101	3.75	1/2 Sq.

<sup>1</sup> Dimension "D" will never be exceeded, but may vary from values shown. When exact dimensions are required, shims up to .03" may be necessary.

<sup>2</sup> All rough casting dimensions may vary by .25" due to casting variations.

<sup>3</sup> Output shaft extension tolerances: +.0000"; -.0005" for shafts up to 1.5" diameter "U". Larger diameter "U", +.000"; -.001".

<sup>4</sup> Input shaft extension tolerances: +.0000"; -.0005" up to 1.5" diameter. Larger diameter "U1", +.000"; -.001".

## Combined Output Shafted Foot Mount OtN32 - 38

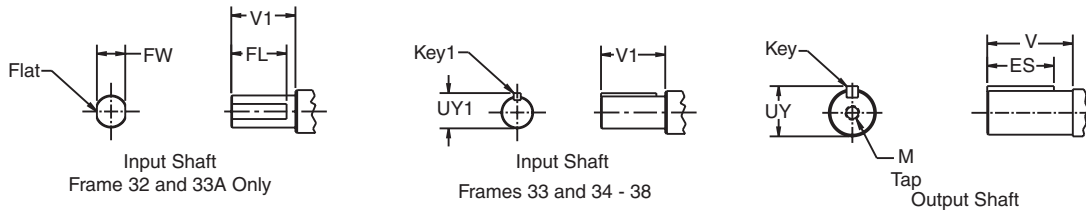
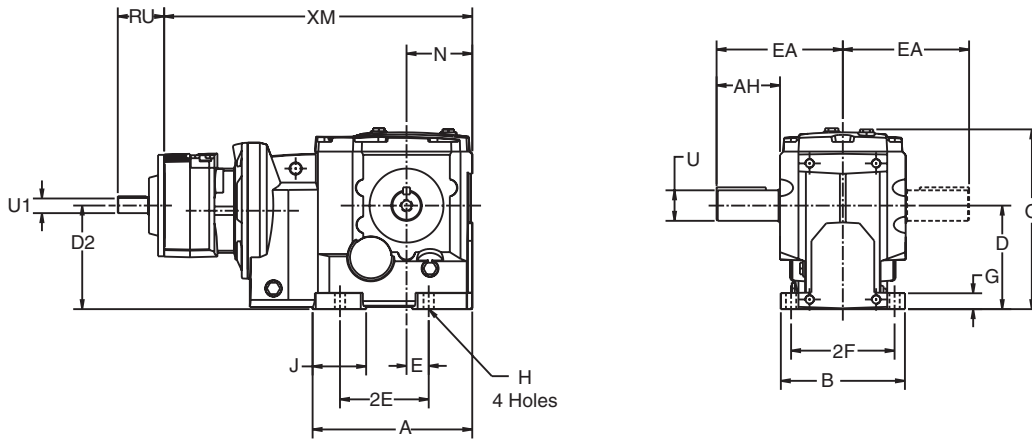

Gear Frame	Version	A	B	D <sup>1</sup>	D2	E	2E	2F	G	H	J	O	N	XM
32	S2	7.81	5.71	4.41	4.06	1.38	5.12	4.72	.73	.43	2.34	8.09	3.03	14.49
33, 33A	S2	8.50	6.61	5.51	4.91	1.18	4.72	5.51	.85	.55	2.86	9.69	3.54	19.90 <sup>4</sup>
	S1	8.08	8.58	4.92	4.87	3.35	6.69	6.10	.79	.55	2.27	10.43	3.54	19.90 <sup>4</sup>
34	S2	10.13	7.87	7.09	5.57	1.57	5.91	6.50	1.07	.71	2.67	12.05	4.49	21.55
	S1	10.69	9.60	6.30	7.16	4.53	9.06	7.68	1.18	.71	3.19	13.39	4.49	21.55
35	S2	11.92	8.66	8.35	6.56	2.17	7.09	7.09	1.18	.87	3.37	13.58	5.20	23.87
	S1	13.07	10.98	7.87	9.00	5.51	11.02	9.06	1.40	.87	4.05	16.22	5.20	23.87
36	S1	17.06	11.41	8.86	8.46	6.99	13.98	9.45	1.57	.87	3.87	16.26	8.74	30.10
37	S1	20.58	12.99	9.84	10.57	8.27	16.54	10.63	1.93	.94	4.78	18.29	10.04	35.43
38	S2	17.85	13.39	14.76	11.48	4.53	13.78	10.63	1.98	1.26	4.06	24.11	8.86	31.00

### Output Shaft

Gear Frame	Version	U <sup>3</sup>	UY	V	AH	EA	Key	ES	M
32	S2	1.250	1.354	2.36	2.46	5.31	1/4 Sq.	2.06	1/2 - 13 x 1.2
33, 33A	S2	1.625	1.783	3.25	3.39	6.73	3/8 Sq.	2.78	5/8 - 11 x 1.38
	S1	1.500	1.657	3.18	3.19	7.12	3/8 Sq.	2.78	5/8 - 11 x 1.38
34	S2	2.000	2.210	3.63	3.76	8.11	1/2 Sq.	3.06	3/4 - 10 x 1.61
	S1	1.750	1.909	3.56	3.66	8.46	3/8 Sq.	3.56	3/4 - 10 x 1.61
35	S2	2.375	2.638	4.61	4.74	9.45	5/8 Sq.	3.81	3/4 - 10 x 1.61
	S1	2.375	2.638	5.73	5.27	10.57	5/8 Sq.	4.81	3/4 - 10 x 1.61
36	S1	2.875	3.20	5.75	5.92	11.94	3/4 Sq.	5.00	3/4 - 10 x 1.61
37	S1	3.625	4.01	6.86	7.04	13.66	7/8 Sq.	6.00	1-8 x 2.13
38	S2	4.375	4.809	8.99	9.97	17.03	1.00 SQ.	7.00	1-8 X 2.25

### Input Shaft

Gear Frame	Version	RU	U1 <sup>5</sup>	FL	FW	UY1	V1	Key1
32, 33A	S2	3.60	.500	.86	.46	-	1.00	-
33	S1, S2	3.17	.625	-	-	.705	1.25	3/16 Sq.
34	S1, S2	3.17	.625	-	-	.705	1.25	3/16 Sq.
35	S1, S2	3.17	.625	-	-	.705	1.25	3/16 Sq.
36	S1	3.17	.625	-	-	.714	1.25	3/16 Sq.
37	S1	3.17	.625	-	-	.714	1.25	3/16 Sq.
38	S2	3.17	.625	-	-	0.714	1.25	3/16 Sq.

<sup>1</sup> Dimension "D" will never be exceeded, but may vary from values shown. When exact dimensions are required, shims up to .03" may be necessary.

<sup>2</sup> All rough casting dimensions may vary by .25" due to casting variations.

<sup>3</sup> Output shaft extension tolerances: +.0000"; -.0005" for shafts up to

1.5" diameter "U". Larger diameter "U", +.000"; -.001".

<sup>4</sup> XM dimension when gear frame 33A is used will be 16.42.

<sup>5</sup> Input shaft extension tolerances: +.0000"; -.0005" up to 1.5" diameter. Larger diameter "U1", +.000"; -.001".

## 2-Stage Output Shafted Flange Mount OtN31 - 32

OtN Series

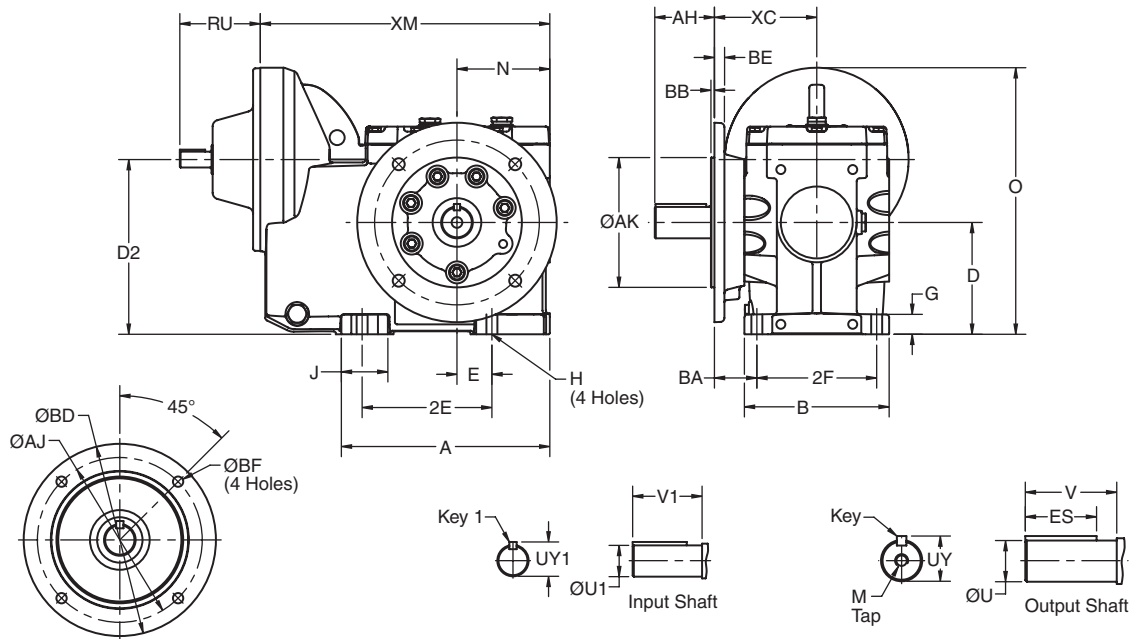

Gear Frame	Version	A	B	D'	D2	E	2E	2F	G	H	J	O	N	BA	XC	XM
3132	S2	5.88	4.65	3.15	4.98	1.97	3.94	3.94	.56	.35	1.53	8.01	3.15	1.54	3.50	10.59
3242	S2	8.22	5.71	4.41	6.89	1.38	5.12	4.72	.79	.43	1.83	10.51	3.66	1.67	4.04	12.36

### Output Shaft

Gear Frame	Version	U <sup>3</sup>	UY	V	AH	Key	ES	M
3132	S2	1.000	1.10	1.97	1.97	1/4 Sq.	1.34	3/8-16 X .87
3242	S2	1.250	1.35	2.36	2.35	1/4 Sq.	2.03	1/2-13 X 1.13

### Output Flange

Gear Frame	Flange Code	AK	AJ	BB	BD	BE	BF
3132	5	4.331	5.12	.14	6.50	.39	.35
	6	3.740	4.53	.14	5.51	.44	.35
3242	5	5.118	6.50	.14	7.87	.39	.47
	6	7.087	8.46	.16	9.84	.47	.55

### Input Shaft

Gear Frame	Version	RU	U1 <sup>4</sup>	UY1	V1	Key1
31	S2	3.17	.625	.705	1.25	3/16 Sq.
32	S2	3.17	.625	.705	1.25	3/16 Sq.

<sup>1</sup> Dimension "D" will never be exceeded, but may vary from values shown. When exact dimensions are required, shims up to .03" may be necessary.

<sup>2</sup> All rough casting dimensions may vary by .25" due to casting variations.

<sup>3</sup> Output shaft extension tolerances: +.0000"; -.0005" for shafts up to 1.5" diameter "U". Larger diameter "U", +.000"; -.001".

<sup>4</sup> Input shaft extension tolerances: +.0000"; -.0005" up to 1.5" diameter. Larger diameter "U1", +.000"; -.001".

## 3-Stage Output Shafted Flange Mount OtN32 - 35

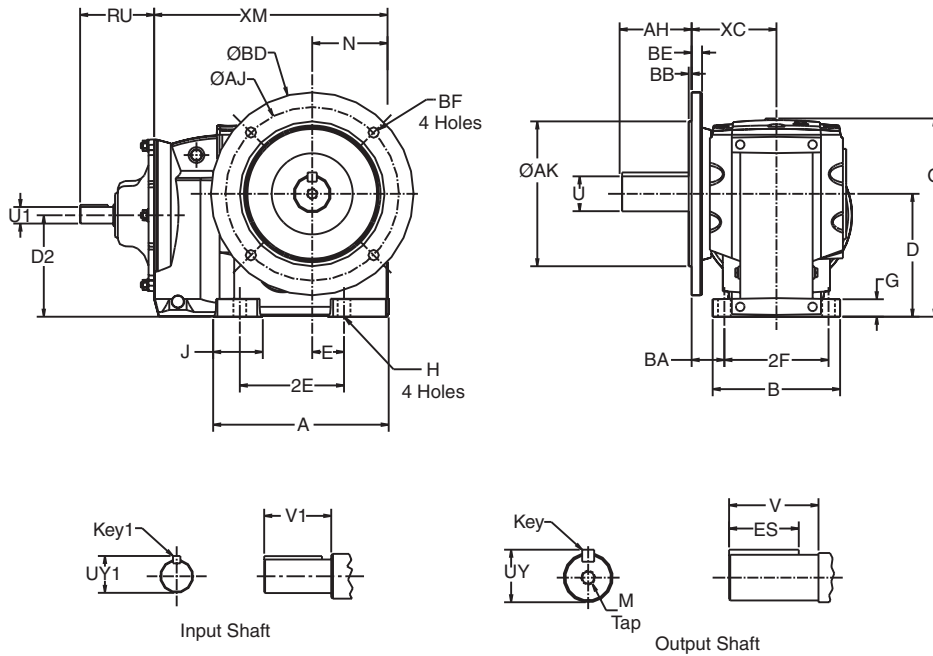

OtN Series

Gear Frame	Version	A	B	D <sup>1</sup>	D2	E	2E	2F	G	H	J	O	N	BA	XC	XM
32	S1, S2	7.81	5.71	4.41	3.78	1.38	5.12	4.71	.73	.43	2.34	8.09	3.03	1.81	4.04	10.04
33	S1, S2	8.50	6.61	5.51	5.24	1.18	4.72	5.51	.85	.55	2.86	9.69	3.54	2.24	4.84	11.97
34	S1, S2	10.13	7.87	7.09	5.90	1.57	5.91	6.50	1.07	.71	2.67	12.05	4.49	1.93	5.18	13.78
35	S2	11.92	8.66	8.35	6.89	2.17	7.09	7.09	1.18	.87	3.45	13.58	5.20	2.22	5.76	15.95

### Output Shaft

Gear Frame	Version	U <sup>3</sup>	UY	V	AH	Key	ES	M
32	S2	1.250	1.354	2.38	2.36	1/4 Sq.	2.06	1/2-13 X 1.12
	S1	1.250	1.354	1.77	1.75	1/4 Sq.	1.45	1/2-13 X 1.12
33	S2	1.625	1.783	3.25	3.15	3/8 Sq.	2.78	5/8-11 X 1.38
	S1	1.500	1.657	3.18	2.28	3/8 Sq.	2.19	5/8-11 X 1.38
34	S2	2.000	2.210	3.94	3.94	1/2 Sq.	3.06	3/4-11 X 1.61
	S1	1.750	1.909	3.56	3.28	3/8 Sq.	3.56	3/4-11 X 1.61
35	S2	2.375	2.646	4.72	4.72	5/8 Sq.	3.81	3/4-11 X 1.61

### Output Flange

Gear Frame	Flange Code	AK	AJ	BB	BD	BE	BF
32	5	5.118	6.50	.14	7.87	.39	.47
	6	7.087	8.46	.16	9.84	.47	.55
33	5	7.087	8.46	.16	9.84	.47	.55
	6	9.055	10.43	.16	11.81	.47	.55
34	5	9.055	10.43	.16	11.81	.59	.55
	6	9.842	11.80	.16	13.77	.59	.71
35	5	9.842	11.80	.20	13.77	.71	.71
	6	11.810	13.77	.20	15.75	.71	.71

### Input Shaft

Gear Frame	Version	RU	U1 <sup>4</sup>	UY1	V1	Key1
32	S1,S2	3.17	.625	.705	1.25	3/16 Sq.
33	S1,S2	3.17	.625	.705	1.25	3/16 Sq.
34	S1,S2	4.75	1.125	1.236	2.25	1/4 Sq.
35	S2	5.03	1.125	1.236	2.25	1/4 Sq.

<sup>1</sup> Dimension "D" will never be exceeded, but may vary from values shown. When exact dimensions are required, shims up to .03" may be necessary.

<sup>2</sup> All rough casting dimensions may vary by .25" due to casting variations.

<sup>3</sup> Output shaft extension tolerances: +.0000"; -.0005" for shafts up to 1.5" diameter "U". Larger diameter "U", +.000"; -.001".

<sup>4</sup> Input shaft extension tolerances: +.0000"; -.0005" up to 1.5" diameter. Larger diameter "U1", +.000"; -.001".

## 3-Stage Output Shafted Flange Mount OtN36 - 38

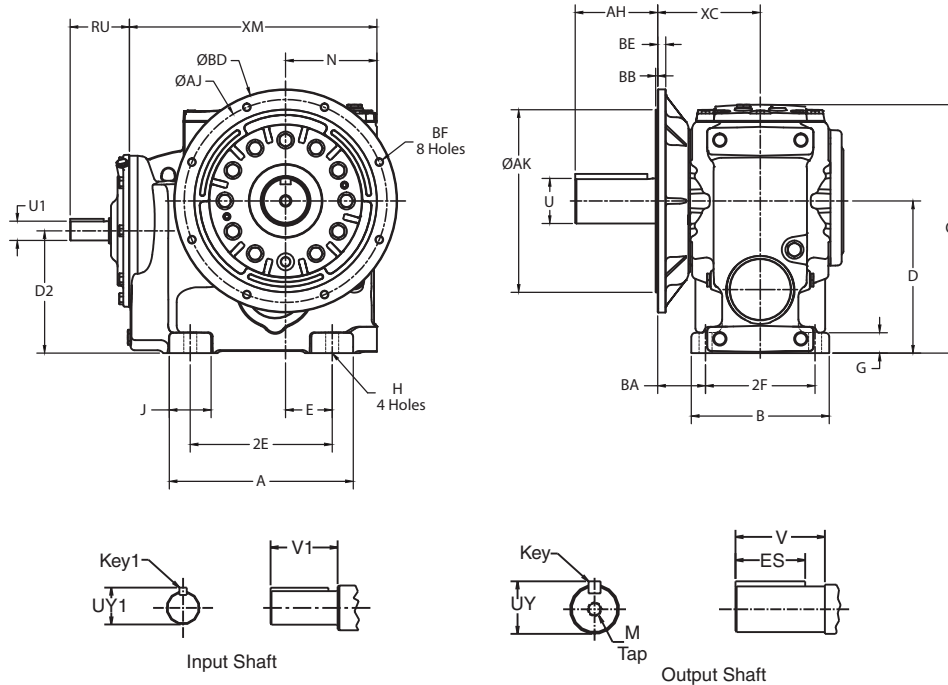

OtN Series

Gear Frame	Version	A	B	D <sup>1</sup>	D2	E	2E	2F	G	H	J	O	N	BA	XC	XM
36	S2	17.06	11.41	8.86	8.86	6.99	13.98	9.45	1.57	.87	3.87	16.26	8.74	4.45	9.17	23.11
37	S2	20.58	12.99	9.84	10.98	8.27	16.54	10.63	1.93	.94	4.78	18.29	10.04	4.45	9.76	28.44
38	S2	17.85	13.39	14.76	11.87	4.53	13.78	10.63	1.98	1.26	4.06	24.11	8.86	4.65	9.96	24.02

### Output Shaft

Gear Frame	Version	U <sup>3</sup>	UY	V	AH	Key	ES	M
36	S1	2.875	3.20	7.68	5.51	3/4 Sq.	5.00	3/4 -10 x 1.61
37	S1	3.625	4.01	8.88	6.69	7/8 Sq.	6.00	1-8 x 2.13
38	S2	4.375	4.809	8.99	9.97	1.00 Sq.	7.00	1-8 X 2.25

### Output Flange

Gear Frame	Flange Code	AJ	AK	BB	BD	BE	BF
36 & 37	5	13.78	15.75	.236	17.70	.79	.71
	6	17.72	19.68	.236	21.65	.63	.87
38	5	17.72	19.69	.200	21.65	.79	.69
	6	21.65	23.62	.236	25.98	.63	.87

### Input Shaft

Gear Frame	Version	RU	U1 <sup>4</sup>	UY1	V1	Key1
36	S1	7.56	1.875	2.101	3.75	1/2 Sq.
37	S1	7.56	1.875	2.101	3.75	1/2 Sq.
38	S2	7.56	1.875	2.101	3.75	1/2 Sq.

<sup>1</sup> Dimension "D" will never be exceeded, but may vary from values shown. When exact dimensions are required, shims up to .03" may be necessary.

<sup>2</sup> All rough casting dimensions may vary by .25" due to casting variations.

<sup>3</sup> Output shaft extension tolerances: +.0000"; -.0005" for shafts up to 1.5" diameter "U". Larger diameter "U", +.000"; -.001".

<sup>4</sup> Input shaft extension tolerances: +.0000"; -.0005" up to 1.5" diameter. Larger diameter "U1", +.000"; -.001".



## Combined Output Shafted Flange Mount OtN32 - 35

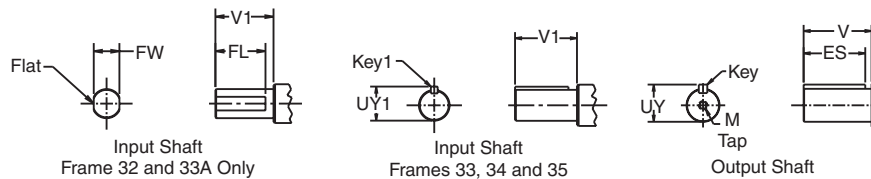
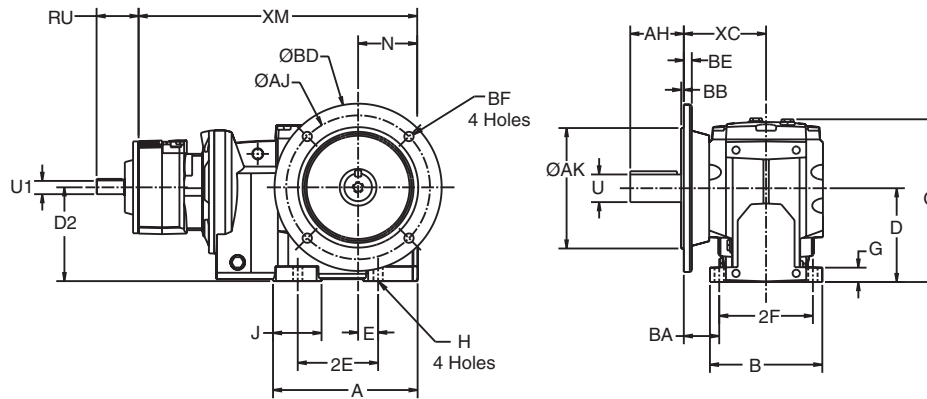

OtN Series

Gear Frame	Version	A	B	D <sup>1</sup>	D2	E	2E	2F	G	H	J	O	N	BA	XC	XM
32	S1,S2	7.81	5.71	4.41	4.06	1.38	5.12	4.71	.73	.43	2.34	8.09	3.03	1.81	4.04	14.49
33,33A	S1,S2	8.50	6.61	5.51	4.91	1.18	4.72	5.51	.85	.55	2.86	9.69	3.54	2.24	4.84	19.90 <sup>4</sup>
34	S1,S2	10.13	7.87	7.09	5.57	1.57	5.91	6.50	1.07	.71	2.67	12.05	4.49	1.93	5.18	21.55
35	S2	11.92	8.66	8.35	6.56	2.17	7.09	7.09	1.18	.87	3.45	13.58	5.20	2.22	5.76	23.87

### Output Shaft

Gear Frame	Version	U <sup>3</sup>	UY	V	AH	Key	ES	M
32	S2	1.250	1.354	2.38	2.36	1/4 Sq.	2.06	1/2-13 X 1.12
	S1	1.250	1.354	1.77	1.75	1/4 Sq.	1.45	1/2-13 X 1.12
33,33A	S2	1.625	1.783	3.25	3.15	3/8 Sq.	2.78	5/8-11 X 1.38
	S1	1.500	1.657	3.18	2.28	3/8 Sq.	2.19	5/8-11 X 1.38
34	S2	2.000	2.210	3.94	3.94	1/2 Sq.	3.06	3/4-10 X 1.61
	S1	1.750	1.909	3.56	3.28	3/8 Sq.	3.56	3/4-10 X 1.61
35	S2	2.375	2.638	4.72	4.72	5/8 Sq.	3.81	3/4-10 X 1.61

### Output Flange

Gear Frame	Flange Code	AK	AJ	BB	BD	BE	BF
32	5	5.118	6.50	.14	7.87	.39	.47
	6	7.087	8.46	.16	9.84	.47	.55
33,33A	5	7.087	8.46	.16	9.84	.47	.55
	6	9.055	10.43	.16	11.81	.47	.55
34	5	9.055	10.43	.16	11.81	.59	.55
	6	9.842	11.80	.16	13.77	.59	.71
35	5	9.842	11.80	.20	13.77	.71	.71
	6	11.810	13.77	.20	15.75	.71	.71

### Input Shaft

Gear Frame	Version	RU	U1 <sup>5</sup>	FL	FW	UY1	V1	Key1
32,33A	S1,S2	3.60	.500	.86	.46	-	1.00	-
33	S1,S2	3.17	.625	-	-	.705	1.25	3/16 Sq.
34	S1,S2	3.17	.625	-	-	.705	1.25	3/16 Sq.
35	S2	3.17	.625	-	-	.705	1.25	3/16 Sq.

<sup>1</sup> Dimension "D" will never be exceeded, but may vary from values shown. When exact dimensions are required, shims up to .03" may be necessary.

<sup>2</sup> All rough casting dimensions may vary by .25" due to casting variations.

<sup>3</sup> Output shaft extension tolerances: +.0000"; -.0005" for shafts up to

1.5" diameter "U". Larger diameter "U", +.000"; -.001".

<sup>4</sup> XM dimension when gear frame 33A is used will be 16.42.

<sup>5</sup> Input shaft extension tolerances: +.0000"; -.0005" up to 1.5" diameter. Larger diameter "U1", +.000"; -.001".

## Combined Output Shafted Flange Mount OtN36 - 38

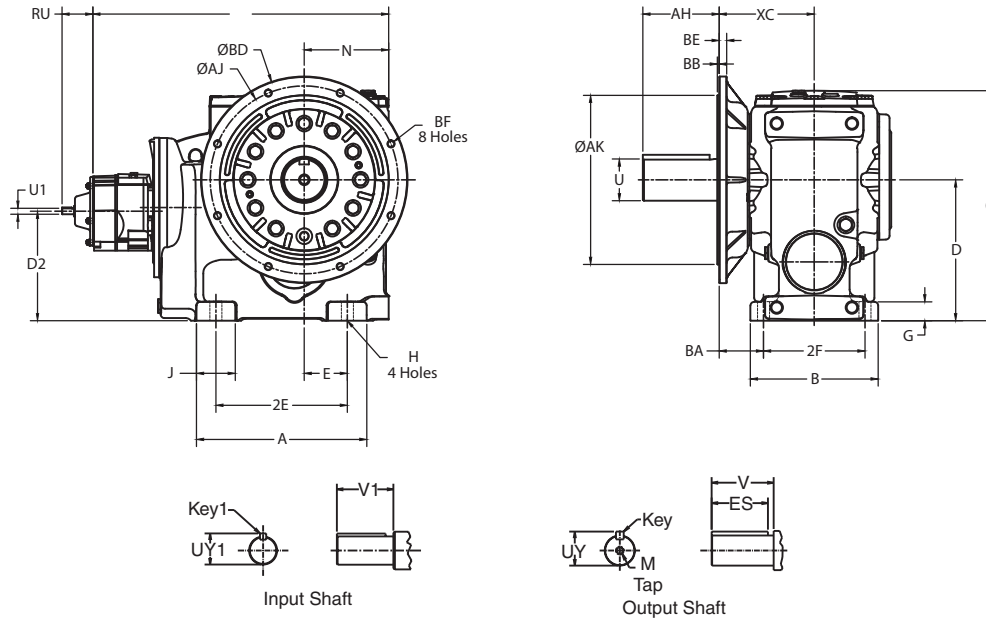

OtN Series

Gear Frame	Version	A	B	D <sup>1</sup>	D2	E	2E	2F	G	H	J	O	N	BA	XC	XM
36	S2	17.06	11.41	8.86	8.46	6.99	13.98	9.45	1.57	.87	3.87	16.26	8.74	4.45	9.17	30.10
37	S2	20.58	12.99	9.84	10.57	8.27	16.54	10.63	1.93	.94	4.78	18.29	10.04	4.45	9.76	35.43
38	S2	17.85	13.39	14.76	11.48	4.53	13.78	10.63	1.98	1.26	4.06	24.11	8.86	4.65	9.96	31.00

### Output Shaft

Gear Frame	Version	U <sup>3</sup>	UY	V	AH	Key	ES	M
36	S1	2.875	3.20	7.68	5.51	3/4 Sq.	5.00	3/4 -10 x 1.61
37	S1	3.625	4.01	8.88	6.69	7/8 Sq.	6.00	1-8 x 2.13
38	S2	4.375	4.809	8.99	9.97	1.00 Sq.	7.00	1-8 X 2.25

### Output Flange

Gear Frame	Flange Code	AJ	AK	BB	BD	BE	BF
36 & 37	5	13.78	15.75	.236	17.70	.79	.71
	6	17.72	19.68	.236	21.65	.63	.87
38	5	17.72	19.69	.200	21.65	.79	.69
	6	21.65	23.62	.236	25.98	.63	.87

### Input Shaft

Gear Frame	Version	RU	U1 <sup>4</sup>	UY1	V1	Key1
36	S1	3.17	.625	.714	1.25	3/16 Sq.
37	S1	3.17	.625	.714	1.25	3/16Sq.
38	S2	3.17	0.625	0.714	1.25	3/16 Sq.

<sup>1</sup> Dimension "D" will never be exceeded, but may vary from values shown. When exact dimensions are required, shims up to .03" may be necessary.

<sup>2</sup> All rough casting dimensions may vary by .25" due to casting variations.

<sup>3</sup> Output shaft extension tolerances: +.0000"; -.0005" for shafts up to 1.5" diameter "U". Larger diameter "U", +.000"; -.001".

<sup>4</sup> Input shaft extension tolerances: +.0000"; -.0005" up to 1.5" diameter. Larger diameter "U1", +.000"; -.001".

## 2-Stage Finished Bore Hollow Shaft OtN31 - 32

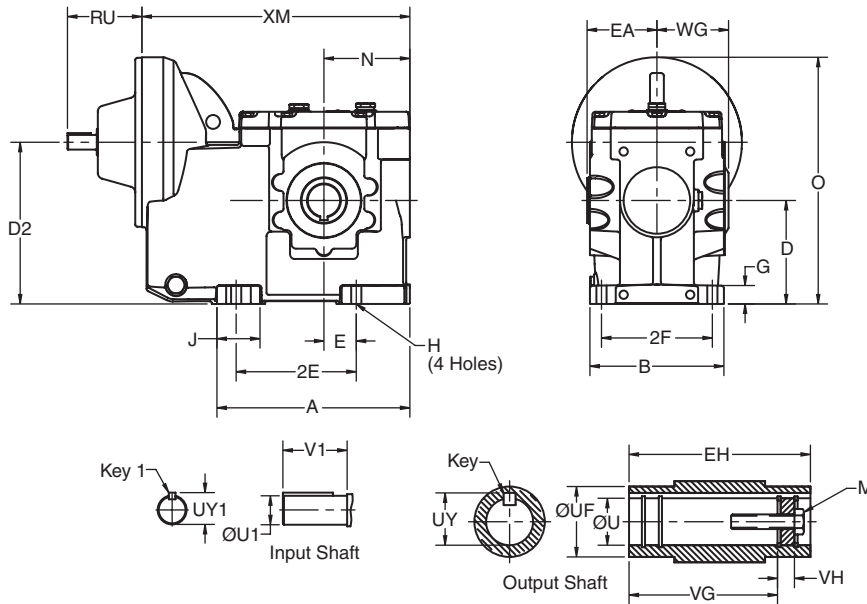

OtN Series

Gear Frame	Version	A	B	D'	D2	E	2E	2F	G	H	J	O	N	WG	XM
3132	S2	5.88	4.65	3.15	4.98	1.97	3.94	3.94	.56	.35	1.53	8.01	3.15	2.85	10.59
3242	S2	8.22	5.71	4.41	6.89	1.38	5.12	4.72	.79	.43	1.83	10.51	3.66	3.22	12.36

### Output Shaft

Gear Frame	Version	EA	EH	U <sup>3,4,6</sup>	UF	UY	VG	VH	Key <sup>8</sup>	M
3132	S2	2.56	5.12	1.250	1.77	1.372	4.31	.37	1/4 X 1/4 X 1 1/2	7/16-14 X 1.00
3242	S2	2.97	5.94	1.375	1.96	1.523	5.06	.37	5/16 X 5/16 1 13/16	1/2-13 X 1.00

### Input Shaft

Gear Frame	Version	RU	U1 <sup>4</sup>	UY1	V1	Key1
31	S2	3.17	.625	.705	1.25	3/16 Sq.
32	S2	3.17	.625	.705	1.25	3/16 Sq.

<sup>1</sup> Dimension "D" will never be exceeded, but may vary from values shown. When exact dimensions are required, shims up to .03" may be necessary.

<sup>2</sup> All rough casting dimensions may vary by .25" due to casting variations.

<sup>3</sup> Driven shaft entry can be from either side of the gear reducer housing by reversing positioning of the snap rings and washer illustrated.

<sup>4</sup> Output finished bore tolerance: +.0020", -.0000 for all diameters.

<sup>5</sup> Input shaft extension tolerances: +.0000"; -.0005" up to 1.5" diameter. Larger diameter "U1", +.000"; -.001".

<sup>6</sup> Refer to Tapered Bushed designs if driven shaft varies from "U" dimensions offered above.

<sup>7</sup> For details of the torque arm kit, refer to page B-129.

<sup>8</sup> Key not supplied with reducer.

## 3-Stage Finished Bore Hollow Shaft Mount OtN32 - 38

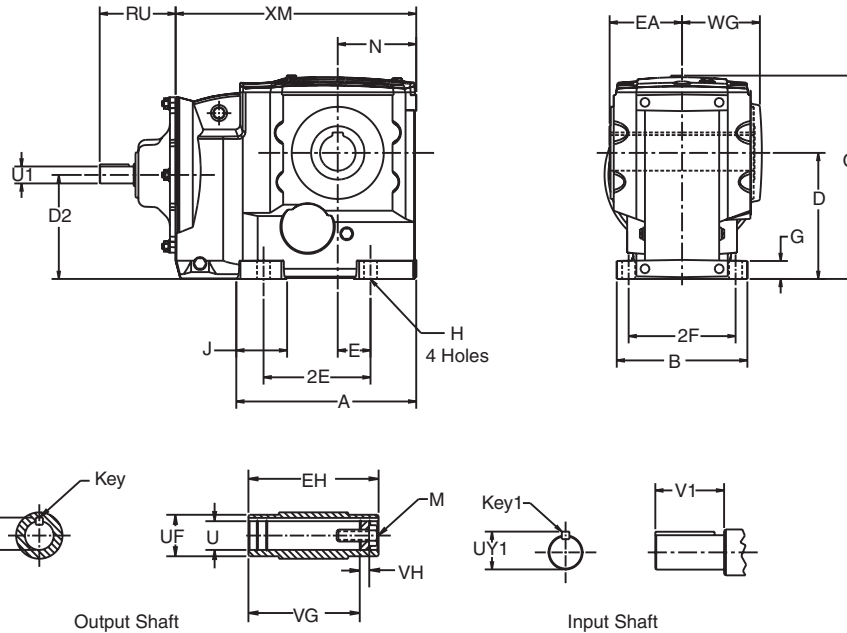

OtN Series

Gear Frame	Version	A	B	D <sup>1</sup>	D2	E	2E	2F	G	H	J	O	N	WG	XM
32	S2	7.81	5.71	4.41	3.78	1.38	5.12	4.71	.73	.43	2.34	8.09	3.03	3.22	10.04
33	S2	8.50	6.61	5.51	5.24	1.18	4.72	5.51	.85	.55	2.86	9.69	3.54	3.73	11.97
34	S2	10.13	7.87	7.09	5.90	1.57	5.91	6.50	1.07	.71	2.67	12.05	4.49	4.66	13.78
35	S2	11.92	8.66	8.35	6.89	2.17	7.09	7.09	1.18	.87	3.45	13.58	5.20	5.15	15.95
36	S2	17.06	11.41	8.86	8.46	6.99	13.98	9.45	1.57	.87	3.87	16.26	8.74	6.78	23.11
37	S2	20.58	12.99	9.84	10.57	8.27	16.54	10.63	1.93	.94	4.78	18.29	10.04	7.44	28.44
38	S2	17.85	13.39	14.76	11.87	4.53	13.78	10.63	1.98	1.26	4.06	24.11	8.86	7.40	24.02

### Output Shaft

Gear Frame	Version	EA	EH	U <sup>4,7</sup>	UF	UY	VG	VH	Key <sup>5</sup>	M
33	S2	3.47	6.94	1.500	2.16	1.674	5.96	.55	3/8 x 3/8 x 2 1/4	5/8-11 x 1.75
34	S2	4.49	8.97	2.000	2.56	2.210	7.44	.79	1/2 x 7/16 x 2 5/8	5/8-11 x 1.75
35	S2	4.83	9.66	2.375	3.54	2.656	8.15	.94	5/8 x 5/8 x 3 5/8	3/4-10 x 2.00
36	S2	6.22	12.44	2.750	3.93	3.037	10.89	1.23	5/8 x 5/8 x 5 1/2	3/4-10 x 2.00
37	S2	6.80	13.59	3.625	4.72	4.019	11.90	1.23	7/8 x 7/8 x 5 1/2	3/4-10 x 2.00
38	S2	6.81	13.74	4.000	5.50	4.316	11.86	.92	1 x 1 x 6 1/2	1-8 x 2.25

### Input Shaft

Gear Frame	Version	RU	U1 <sup>6</sup>	UY1	V1	Key1
32	S2	3.17	.625	.705	1.25	3/16 Sq.
33	S2	3.17	.625	.705	1.25	3/16 Sq.
34	S2	4.75	1.125	1.236	2.25	1/4 Sq.
35	S2	5.03	1.125	1.236	2.25	1/4 Sq.
36	S2	7.56	1.875	2.101	3.75	1/2 Sq.
37	S2	7.56	1.875	2.101	3.75	1/2 Sq.
38	S2	7.56	1.875	2.101	3.75	1/2 Sq.

<sup>1</sup> Dimension "D" will never be exceeded, but may vary from values shown. When exact dimensions are required, shims up to .03" may be necessary.

<sup>2</sup> All rough casting dimensions may vary by .25" due to casting variations.

<sup>3</sup> Driven shaft entry can be from either side of the gear reducer housing by reversing positioning of the snap rings and washer illustrated.

<sup>4</sup> Output finished bore tolerance: +.0020", -.0000 for all diameters.

<sup>5</sup> Output key supplied only on frame 34 in "S2" version.

<sup>6</sup> Input shaft extension tolerances: +.0000"; -.0005" up to 1.5" diameter. Larger diameter "U1", +.000"; -.001".

<sup>7</sup> Refer to Tapered Bushed designs if driven shaft varies from "U" dimensions offered above. (Frames 32 - 35 only).

<sup>8</sup> For details of the torque arm kit, refer to pages B-129 and B-130.

## Combined Finished Bore Hollow Shaft OtN32 - 38

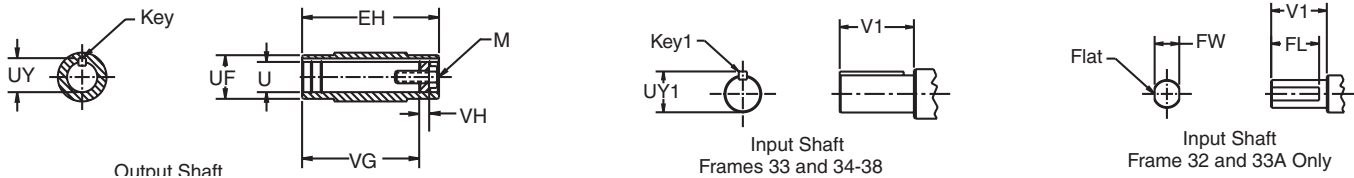
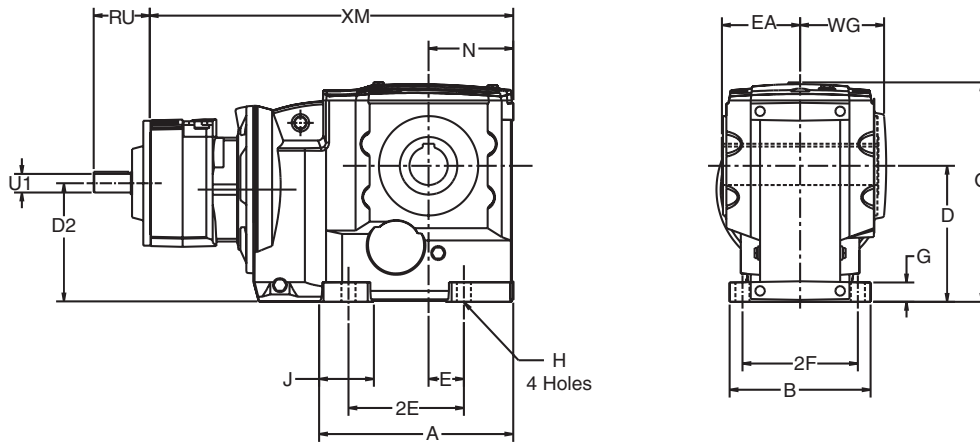

Gear Frame	Version	A	B	D <sup>1</sup>	D2	E	2E	2F	G	H	J	O	N	WG	XM
32	S2	7.81	5.71	4.41	4.06	1.38	5.12	4.71	.73	.43	2.34	8.09	3.03	3.22	14.49
33, 33A	S2	8.50	6.61	5.51	4.91	1.18	4.72	5.51	.85	.55	2.86	9.69	3.54	3.73	19.90 <sup>7</sup>
34	S2	10.13	7.87	7.09	5.57	1.57	5.91	6.50	1.07	.71	2.67	12.05	4.49	4.66	21.55
35	S2	11.92	8.66	8.35	6.56	2.17	7.09	7.09	1.18	.87	3.45	13.58	5.20	5.15	23.87
36	S2	17.06	11.41	8.86	8.46	6.99	13.98	9.45	1.57	.87	3.87	16.26	8.74	6.78	30.10
37	S2	20.58	12.99	9.84	10.57	8.27	16.54	10.63	1.93	.94	4.78	18.29	10.04	7.44	35.43
38	S2	17.85	13.39	14.76	11.48	4.53	13.78	10.63	1.98	1.26	4.06	24.11	8.86	7.40	31.00

### Output Shaft

Gear Frame	Version	EA	EH	U <sup>4,8</sup>	UF	UY	VG	VH	Key <sup>5</sup>	M
32	S2	2.98	5.95	1.375	1.96	1.523	5.20	.55	5/16 x 5/16 x 1 13/16	1/2-13 x 1.00
33, 33A	S2	3.47	6.94	1.500	2.16	1.674	5.96	.55	3/8 x 3/8 x 2 1/4	5/8-11 x 1.75
34	S2	4.49	8.97	2.000	2.56	2.210	7.44	.79	1/2 x 7/16 x 2 5/8	5/8-11 x 1.75
35	S2	4.83	9.66	2.375	3.54	2.656	8.15	.94	5/8 x 5/8 x 3 5/8	3/4-10 x 2.00
36	S2	6.22	12.44	2.750	3.93	3.037	10.89	1.23	5/8 x 5/8 x 5 1/2	3/4-10 x 2.00
37	S2	6.80	13.59	3.625	4.72	4.019	11.90	1.23	7/8 x 7/8 x 5 1/2	3/4-10 x 2.00
38	S2	6.81	13.74	4.000	5.50	4.316	11.86	.92	1 X 1 X 6 1/2	1-8 X 2.25

### Input Shaft

Gear Frame	Version	RU	U <sup>1,6</sup>	FL	FW	UY1	V1	Key1
32, 33A	S2	3.60	.500	.86	.46	-	1.00	-
33	S2	3.17	.625	-	-	.705	1.25	3/16 Sq.
34	S2	3.17	.625	-	-	.705	1.25	3/16 Sq.
35	S2	3.17	.625	-	-	.705	1.25	3/16 Sq.
36	S2	3.17	.625	-	-	.714	1.25	3/16 Sq.
37	S2	3.17	.625	-	-	.714	1.25	3/16 Sq.
38	S2	3.17	.625	-	-	.714	1.25	3/16 Sq.

<sup>1</sup> Dimension "D" will never be exceeded, but may vary from values shown. When exact dimensions are required, shims up to .03" may be necessary.

<sup>2</sup> All rough casting dimensions may vary by .25" due to casting variations.

<sup>3</sup> Driven shaft entry can be from either side of the gear reducer housing by reversing positioning of the snap rings and washer illustrated.

<sup>4</sup> Output finished bore tolerance: +.0020", -.0000 for all diameters.

<sup>5</sup> Output key supplied only on frame 34 in "S2" version.

<sup>6</sup> Input shaft extension tolerances: +.0000"; -.0005" up to 1.5" diameter. Larger diameter "U1", +.000"; -.001".

<sup>7</sup> XM dimension when gear frame 33A is used will be 16.42.

<sup>8</sup> Refer to Tapered Bushed designs if driven shaft varies from "U" dimensions offered above. (Frames 32 - 37 only).

<sup>9</sup> For details of the torque arm kit, refer to pages B-129 and B-130.

## 2-Stage Finished Bore Hollow Shaft Face Mount OtN31 - 32

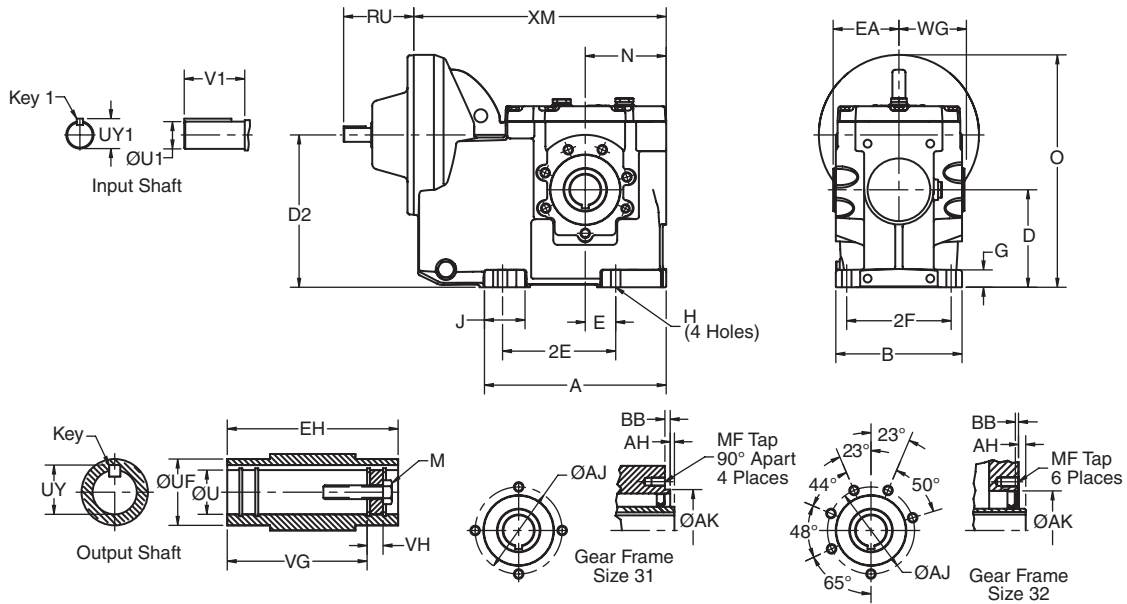

OtN Series

Gear Frame	Version	A	B	D'	D2	E	2E	2F	G	H	J	O	N	WG	XM
3132	S2	5.88	4.65	3.15	4.98	1.97	3.94	3.94	.56	.35	1.53	8.01	3.15	2.85	10.59
3242	S2	8.22	5.71	4.41	6.89	1.38	5.12	4.72	.79	.43	1.83	10.51	3.66	3.22	12.36

### Output Shaft

Gear Frame	Version	EA	EH	U <sup>3,4</sup>	UF	UY	VG	VH	Key <sup>6</sup>	M
3132	S2	2.56	5.12	1.250	1.77	1.372	4.31	.37	1/4 X 1/4 X 1 1/2	7/16-14 X 1.00
3242	S2	2.97	5.94	1.375	1.96	1.523	5.06	.37	5/16 X 5/16 1 13/16	1/2-13 X 1.00

### Face Mount

Gear Frame	Version	AH	AJ	AK	BB	MF
31	S2	.20	3.740	3.35	.14	M8-1.25 X12
32	S2	.12	3.94	3.15	.16	M10-1.50 X 22

### Input Shaft

Gear Frame	Version	RU	U1 <sup>5</sup>	UY1	V1	Key1
31	S2	3.17	.625	.705	1.25	3/16 Sq.
32	S2	3.17	.625	.705	1.25	3/16 Sq.

<sup>1</sup> Dimension "D" will never be exceeded, but may vary from values shown. When exact dimensions are required, shims up to .03" may be necessary.

<sup>2</sup> All rough casting dimensions may vary by .25" due to casting variations.

<sup>3</sup> Driven shaft entry can be from either side of the gear reducer housing by reversing positioning of the snap rings and washer illustrated.

<sup>4</sup> Output finished bore tolerance: +.0020", -.0000 for all diameters.

<sup>5</sup> Input shaft extension tolerances: +.0000"; -.0005" up to 1.5" diameter. Larger diameter "U1", +.000"; -.001".

<sup>6</sup> Key not supplied with reducer.

## 3-Stage Finished Bore Hollow Shaft Face Mount OtN32 - 35

OtN Series

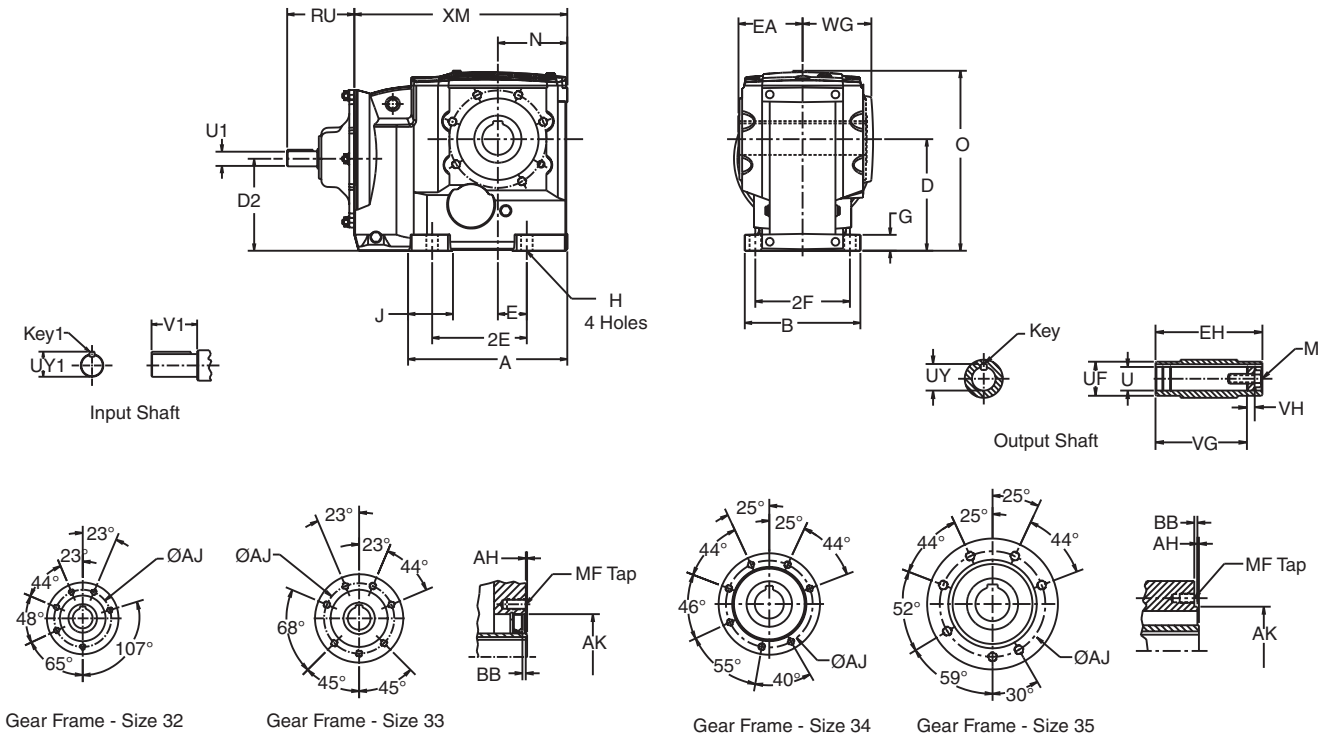

Gear Frame	Version	A	B	D <sup>1</sup>	D2	E	2E	2F	G	H	J	O	N	WG	XM
32	S2	7.81	5.71	4.41	3.78	1.38	5.12	4.71	.73	.43	2.34	8.09	3.03	3.15	10.04
33	S2	8.50	6.61	5.51	5.24	1.18	4.72	5.51	.85	.55	2.86	9.69	3.54	3.63	11.97
34	S2	10.13	7.87	7.09	5.90	1.57	5.91	6.50	1.07	.71	2.67	12.05	4.49	4.66	13.78
35	S2	11.92	8.66	8.35	6.89	2.17	7.09	7.09	1.18	.87	3.45	13.58	5.20	5.15	15.95

### Face Mount

Gear Frame	Version	AH	AJ	AK	BB	MF
32	S2	.12	3.94	3.15	.16	M10-1.50 X 22
33	S2	.12	4.84	3.94	.16	M12-1.75 X 22
34	S2	.14	5.98	5.12	.28	M12-1.75 X 22
35	S2	.13	7.48	6.10	.28	M16-2.00 X 27

### Output Shaft

Gear Frame	Version	EA	EH	U <sup>4</sup>	UF	UY	VG	VH	Key <sup>5</sup>	M
32	S2	2.98	5.95	1.375	1.96	1.523	5.20	.55	5/16 X 5/16 X 1 13/16	1/2-13 X 1.00
33	S2	3.47	6.94	1.500	2.16	1.674	5.96	.55	3/8 X 3/8 X 2 1/4	5/8-11 X 1.75
34	S2	4.49	8.97	2.000	2.56	2.210	7.44	.79	1/2 X 7/16 X 2 5/8	5/8-11 X 1.75
35	S2	4.83	9.66	2.375	3.54	2.656	8.15	.94	5/8 X 5/8 X 3 5/8	3/4-10 X 2.00

### Input Shaft

Gear Frame	Version	RU	U1 <sup>6</sup>	UY1	V1	Key1
32	S2	3.17	.625	.705	1.25	3/16 Sq.
33	S2	3.17	.625	.705	1.25	3/16 Sq.
34	S2	4.75	1.125	1.236	2.25	1/4 Sq.
35	S2	5.03	1.125	1.236	2.25	1/4 Sq.

<sup>1</sup> Dimension "D" will never be exceeded, but may vary from values shown. When exact dimensions are required, shims up to .03" may be necessary.

<sup>2</sup> All rough casting dimensions may vary by .25" due to casting variations.

<sup>3</sup> Driven shaft entry can be from either side of the gear reducer

housing by reversing positioning of the snap rings and washer illustrated.

<sup>4</sup> Output finished bore tolerance: +.0020", -.0000 for all diameters.

<sup>5</sup> Output key supplied only on frame 34 in "S2" version.

<sup>6</sup> Input shaft extension tolerances: +.0000"; -.0005" up to 1.5" diameter. Larger diameter "U1", +.000"; -.001".



**3-Stage Finished Bore Hollow Shaft Face Mount**  
**OtN36 - 38**

OtN Series

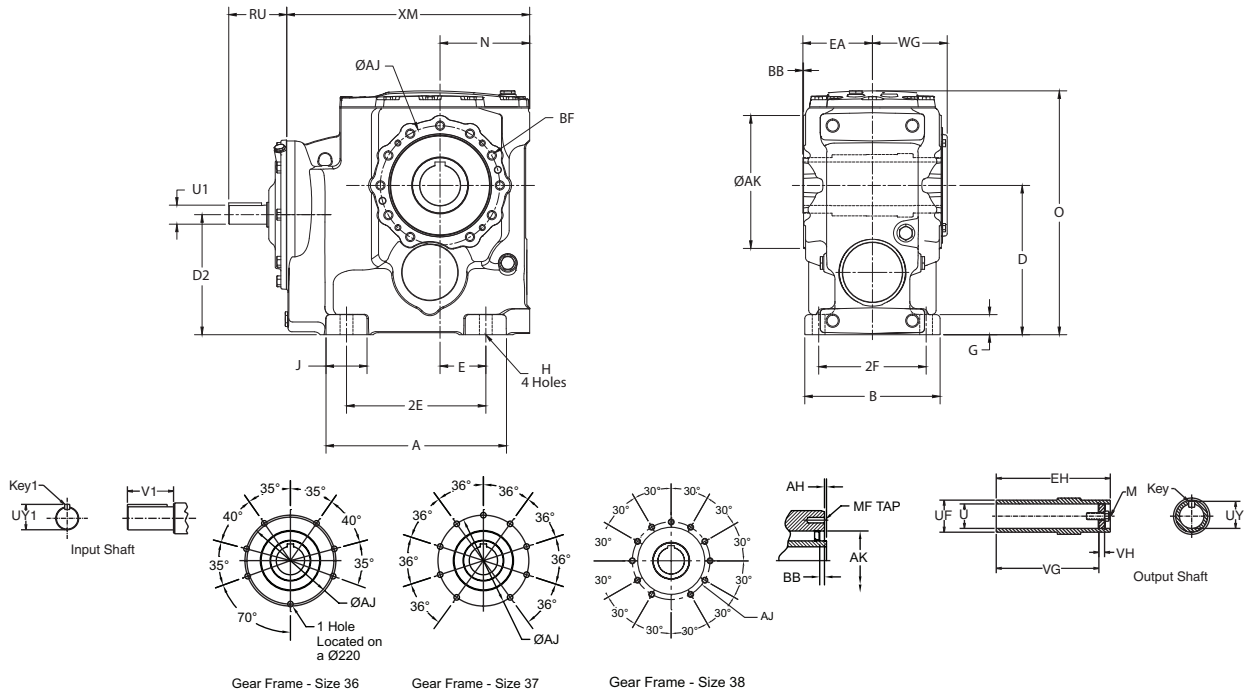

Gear Frame	Version	A	B	D <sup>1</sup>	D2	E	2E	2F	G	H	J	O	N	WG	XM
36	S2	17.06	11.41	8.86	8.86	6.99	13.98	9.45	1.57	.87	3.87	16.26	8.74	6.78	23.11
37	S2	20.58	12.99	9.84	10.98	8.27	16.54	10.63	1.93	.94	4.78	18.29	10.04	7.44	28.44
38	S2	17.85	13.39	14.76	11.87	4.53	13.78	10.63	1.98	1.26	4.06	24.11	8.86	7.40	24.02

**Face Mount**

Gear Frame	Version	AH	AJ	AK	BB	MF
36	S2	.20	9.06	5.91	.28	M16-2.0 X 27
37	S2	.20	9.06	7.09	.28	M20-2.5 X 35
38	S2	.10	11.81	9.84	.20	M20-2.00 X 35

**Output Shaft**

Gear Frame	Version	EA	EH	U <sup>4</sup>	UF	UY	VG	VH	Key <sup>6</sup>	M
36	S2	6.22	12.44	2.750	3.93	3.037	10.89	1.23	5/8 x 5/8 x 5 1/2	3/4-10 x 2.00
37	S2	6.80	13.59	3.625	4.72	4.019	11.90	1.23	7/8 x 7/8 x 5 1/2	3/4-10 x 2.00
38	S2	6.81	13.74	4.000	5.50	4.316	11.86	.92	1 X 1 X 6 1/2	1-8 X 2.25

**Input Shaft**

Gear Frame	Version	RU	U1 <sup>6</sup>	UY1	V1	Key1
36	S2	7.56	1.875	2.101	3.75	1/2 Sq.
37	S2	7.56	1.875	2.101	3.75	1/2 Sq.
38	S2	7.56	1.875	2.101	3.75	1/2 Sq.

<sup>1</sup> Dimension "D" will never be exceeded, but may vary from values shown. When exact dimensions are required, shims up to .03" may be necessary.  
<sup>2</sup> All rough casting dimensions may vary by .25" due to casting variations.  
<sup>3</sup> Driven shaft entry can be from either side of the gear reducer housing by reversing positioning of the snap rings and washer illustrated.  
<sup>4</sup> Output finished bore tolerance: +.0020", -.0000 for all diameters.  
<sup>5</sup> Input shaft extension tolerances: +.0000"; -.0005" up to 1.5" diameter. Larger diameter "U1", +.000"; -.001".  
<sup>6</sup> Key not supplied with reducer.

**Combined Finished Bore Hollow Shaft Face Mount**  
**OtN32 - 35**

OtN Series

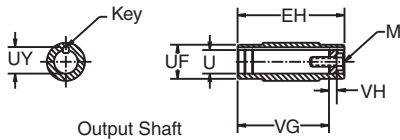
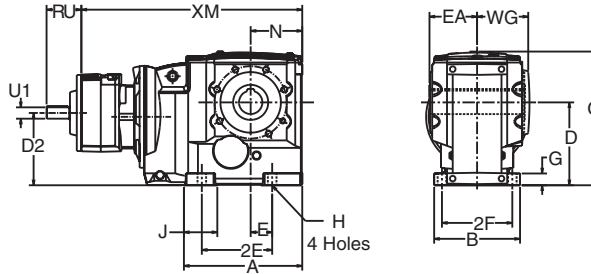

Output Shaft

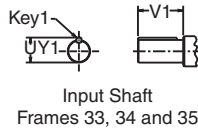

Input Shaft  
Frames 33, 34 and 35

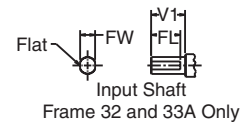

Input Shaft  
Frame 32 and 33A Only

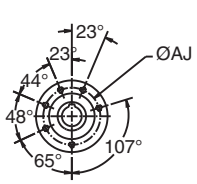

Gear Frame - Size 32

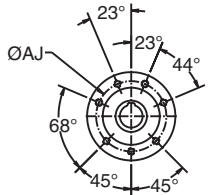

Gear Frame - Size 33

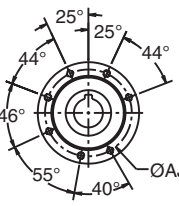
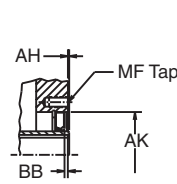

Gear Frame - Size 34

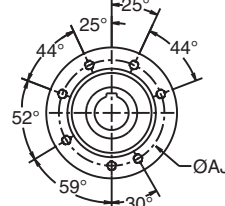

Gear Frame - Size 35

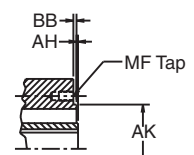

Gear Frame	Version	A	B	D <sup>1</sup>	D2	E	2E	2F	G	H	J	O	N	WG	XM
32	S2	7.81	5.71	4.41	4.06	1.38	5.12	4.71	.73	.43	2.34	8.09	3.03	3.15	14.49
33,33A	S2	8.50	6.61	5.51	4.91	1.18	4.72	5.51	.85	.55	2.86	9.69	3.54	3.63	19.90 <sup>7</sup>
34	S2	10.13	7.87	7.09	5.57	1.57	5.91	6.50	1.07	.71	2.67	12.05	4.49	4.66	21.55
35	S2	11.92	8.66	8.35	6.56	2.17	7.09	7.09	1.18	.87	3.45	13.58	5.20	5.15	23.87

Face Mount

Gear Frame	Version	AH	AJ	AK	BB	MF
32	S2	.12	3.94	3.15	.16	M10-1.50 X 22
33,33A	S2	.12	4.84	3.94	.16	M12-1.75 X 22
34	S2	.14	5.98	5.12	.28	M12-1.75 X 22
35	S2	.13	7.48	6.10	.28	M16-2.00 X 27

Output Shaft

Gear Frame	Version	EA	EH	U <sup>4</sup>	UF	UY	VG	VH	Key <sup>5</sup>	M
32	S2	2.98	5.95	1.375	1.96	1.523	5.20	.55	5/16 X 5/16 X 1 13/16	1/2-13 X 1.00
33,33A	S2	3.47	6.94	1.500	2.16	1.674	5.96	.55	3/8 X 3/8 X 2 1/4	5/8-11 X 1.75
34	S2	4.49	8.97	2.000	2.56	2.210	7.44	.79	1/2 X 7/16 X 2 5/8	5/8-11 X 1.75
35	S2	4.83	9.66	2.375	3.54	2.656	8.15	.94	5/8 X 5/8 X 3 5/8	3/4-10 X 2.00

Input Shaft

Gear Frame	Version	RU	U1 <sup>6</sup>	FL	FW	UY1	V1	Key1
32,33A	S2	3.60	.500	.86	.46	-	1.00	-
33	S2	3.17	.625	-	-	.705	1.25	3/16 Sq.
34	S2	3.17	.625	-	-	.705	1.25	3/16 Sq.
35	S2	3.17	.625	-	-	.705	1.25	3/16 Sq.

<sup>1</sup> Dimension "D" will never be exceeded, but may vary from values shown. When exact dimensions are required, shims up to .03" may be necessary.

<sup>2</sup> All rough casting dimensions may vary by .25" due to casting variations.

<sup>3</sup> Driven shaft entry can be from either side of the gear reducer

housing by reversing positioning of the snap rings and washer illustrated.

<sup>4</sup> Output finished bore tolerance: +.0020", -.0000 for all diameters.

<sup>5</sup> Output key supplied only on frame 34 in "S2" version.

<sup>6</sup> Input shaft extension tolerances: +.0000"; -.0005" up to 1.5" diameter. Larger diameter "U1", +.000"; -.001".

<sup>7</sup> XM dimension when gear frame 33A is used will be 16.42.

## Combined Finished Bore Hollow Shaft Face Mount OtN36 - 38

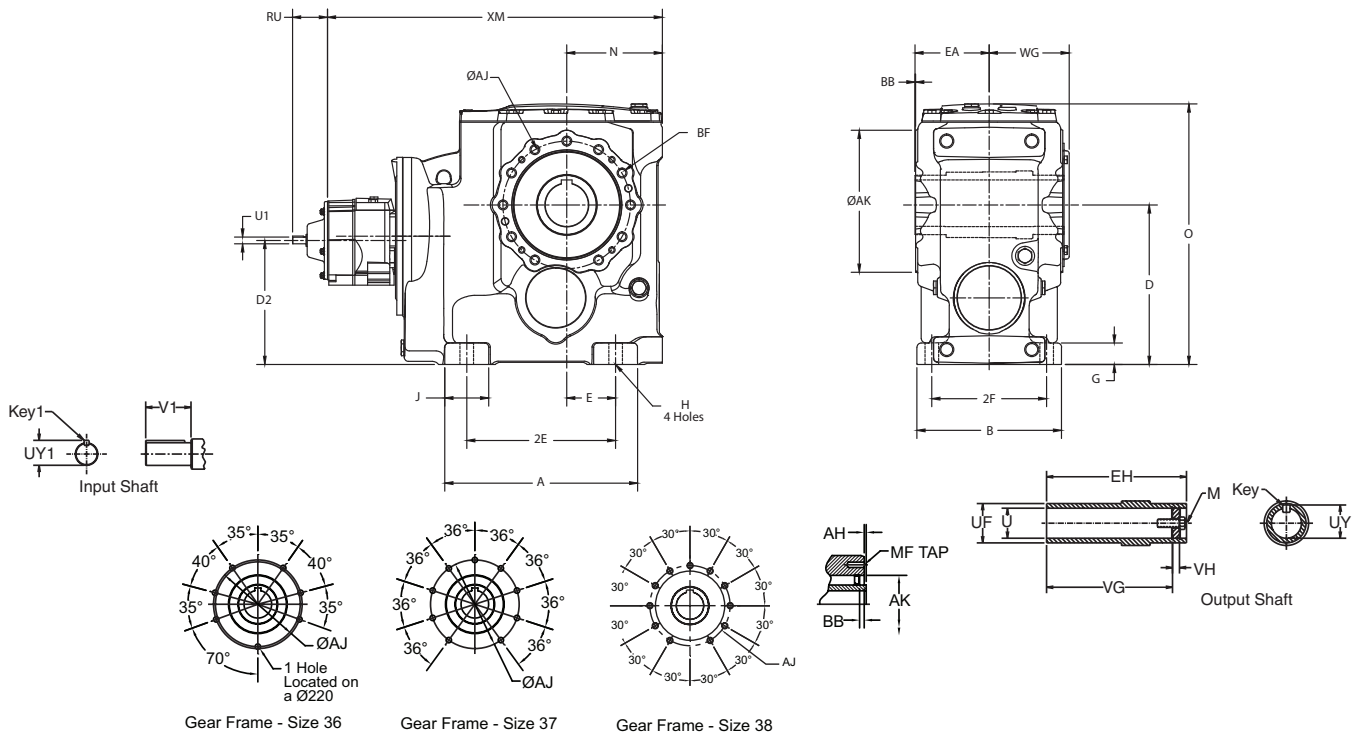

OtN Series

Gear Frame	Version	A	B	D <sup>1</sup>	D2	E	2E	2F	G	H	J	O	N	WG	XM
36	S2	17.06	11.41	8.86	8.46	6.99	13.98	9.45	1.57	.87	3.87	16.26	8.74	6.78	30.10
37	S2	20.58	12.99	9.84	10.57	8.27	16.54	10.63	1.93	.94	4.78	18.29	10.04	7.44	37.49
38	S2	17.85	13.39	14.76	11.48	4.53	13.78	10.63	1.98	1.26	4.06	24.11	8.86	7.40	31.00

### Face Mount

Gear Frame	Version	AJ	AK	BB	MF
36	S2	9.06	5.91	.28	M16-2.00 X 27
37	S2	9.06	7.09	.28	M20-2.50 X 35
38	S2	11.81	9.84	.20	M20-2.00 X 35

### Output Shaft

Gear Frame	Version	EA	EH	U <sup>4</sup>	UF	UY	VG	VH	Key <sup>5</sup>	M
36	S2	6.22	12.44	2.750	3.93	3.037	10.89	1.23	5/8 x 5/8 x 5 1/2	3/4-10 x 2.00
37	S2	6.80	13.59	3.625	4.72	4.019	11.90	1.23	7/8 x 7/8 x 5 1/2	3/4-10 x 2.00
38	S2	6.81	13.74	4.000	5.50	4.316	11.86	.92	1 X 1 X 6 1/2	1-8 X 2.25

### Input Shaft

Gear Frame	Version	RU	U1 <sup>5</sup>	UY1	V1	Key1
36	S2	3.17	.625	.714	1.25	3/16 Sq.
37	S2	3.17	.625	.714	1.25	3/16 Sq.
38	S2	3.17	.625	.714	1.25	3/16 Sq.

<sup>1</sup> Dimension "D" will never be exceeded, but may vary from values shown. When exact dimensions are required, shims up to .03" may be necessary.

<sup>2</sup> All rough casting dimensions may vary by .25" due to casting variations.

<sup>3</sup> Driven shaft entry can be from either side of the gear reducer

housing by reversing positioning of the snap rings and washer illustrated.

<sup>4</sup> Output finished bore tolerance: +.0020", -.0000 for all diameters.

<sup>5</sup> Input shaft extension tolerances: +.0000"; -.0005" up to 1.5" diameter. Larger diameter "U1", +.000"; -.001".

<sup>6</sup> Key not supplied with reducer.

## 2-Stage Finished Bore Hollow Shaft Flange Mount OtN31 - 32

OtN Series

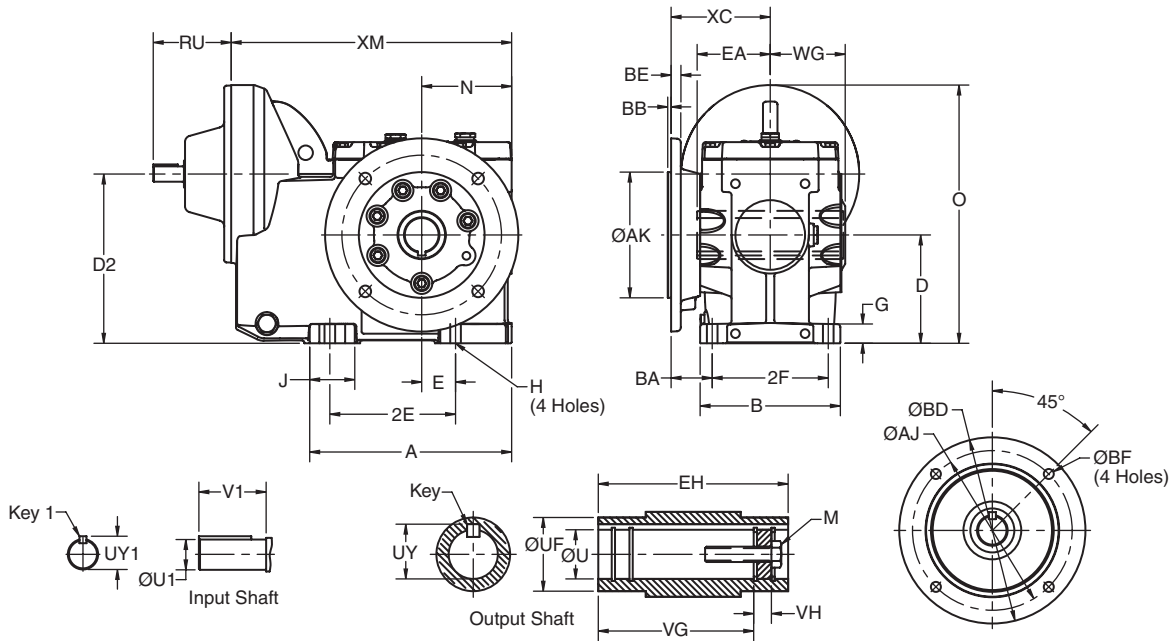

Gear Frame	Version	A	B	D <sup>1</sup>	D2	E	2E	2F	G	H	J	O	N	BA	WG	XC	XM
3132	S2	5.88	4.65	3.15	4.98	1.97	3.94	3.94	.56	.35	1.53	8.01	3.15	1.54	2.85	3.50	10.59
3242	S2	8.22	5.71	4.41	6.89	1.38	5.12	4.72	.79	.43	1.83	10.51	3.66	1.67	3.22	4.04	12.36

### Output Shaft

Gear Frame	Version	EA	EH	U <sup>3,4</sup>	UF	UY	VG	VH	Key <sup>6</sup>	M
3132	S2	2.56	5.12	1.250	1.77	1.372	4.31	.37	1/4 X 1/4 X 1 1/2	7/16-14 X 1.00
3242	S2	2.97	5.94	1.375	1.96	1.523	5.06	.37	5/16 X 5/16 X 1 13/16	1/2-13 X 1.00

### Output Flange

Gear Frame	Flange Code	AK	AJ	BB	BD	BE	BF
3132	5	4.331	5.12	.14	6.50	.39	.35
	6	3.740	4.53	.14	5.51	.44	.35
3242	5	5.118	6.50	.14	7.87	.39	.47
	6	7.087	8.46	.16	9.84	.47	.55

### Input Shaft

Gear Frame	Version	RU	U1 <sup>5</sup>	UY1	V1	Key1
31	S2	3.17	.625	.705	1.25	3/16 Sq.
32	S2	3.17	.625	.705	1.25	3/16 Sq.

<sup>1</sup> Dimension "D" will never be exceeded, but may vary from values shown. When exact dimensions are required, shims up to .03" may be necessary.

<sup>2</sup> All rough casting dimensions may vary by .25" due to casting variations.  
<sup>3</sup> Driven shaft entry can be from either side of the gear reducer housing by reversing positioning of the snap rings and washer illustrated.

<sup>4</sup> Output finished bore tolerance: +.0020", -.0000 for all diameters.

<sup>5</sup> Input shaft extension tolerances: +.0000"; -.0005" up to 1.5" diameter. Larger diameter "U1", +.000"; -.001".

<sup>6</sup> Key not supplied with reducer.

**3-Stage Finished Bore Hollow Shaft Flange Mount**  
**OtN32 - 35**

**OtN Series**

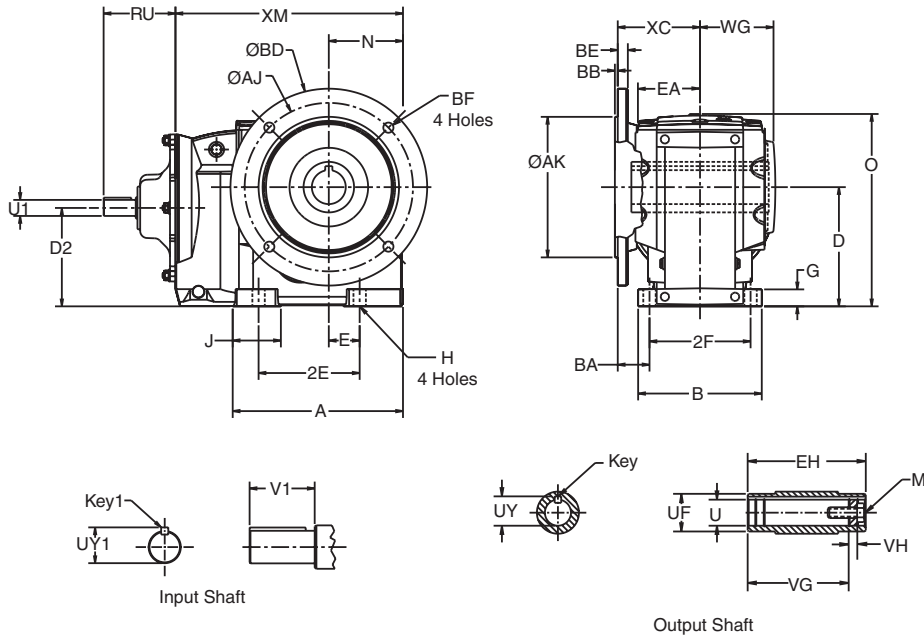

Gear Frame	Version	A	B	D <sup>1</sup>	D2	E	2E	2F	G	H	J	O	N	BA	WG	XC	XM
32	S2	7.81	5.71	4.41	3.78	1.38	5.12	4.71	.73	.43	2.34	8.09	3.03	1.81	3.22	4.04	10.04
33	S2	8.50	6.61	5.51	5.24	1.18	4.72	5.51	.85	.55	2.86	9.69	3.54	2.08	3.73	4.84	11.97
34	S2	10.13	7.87	7.09	5.90	1.57	5.91	6.50	1.07	.71	2.67	12.05	4.49	1.93	4.66	5.18	13.78
35	S2	11.92	8.66	8.35	6.89	2.17	7.09	7.09	1.18	.87	3.45	13.58	5.20	2.22	5.15	5.77	15.95

**Output Shaft**

Gear Frame	Version	EA	EH	U <sup>4</sup>	UF	UY	VG	VH	Key <sup>5</sup>	M
32	S2	2.98	5.95	1.375	1.96	1.523	5.20	.55	5/16 X 5/16 X 1 13/16	1/2-13 X 1.00
33	S2	3.47	6.94	1.500	2.16	1.674	5.96	.55	3/8 X 3/8 X 2 1/4	5/8-11 X 1.75
34	S2	4.49	8.97	2.000	2.56	2.210	7.44	.79	1/2 X 7/16 X 2 5/8	5/8-11 X 1.75
35	S2	4.83	9.66	2.375	3.54	2.656	8.15	.94	5/8 X 5/8 X 3 5/8	3/4-10 X 2.00

**Output Flange**

Gear Frame	Flange Code	AK	AJ	BB	BD	BE	BF
32	5	5.118	6.50	.14	7.87	.39	.47
	6	7.087	8.46	.16	9.84	.47	.55
33	5	7.087	8.46	.16	9.84	.47	.55
	6	9.055	10.43	.16	11.81	.47	.55
34	5	9.055	10.43	.16	11.81	.59	.55
	6	9.842	11.80	.16	13.77	.59	.71
35	5	9.842	11.80	.20	13.77	.71	.71
	6	11.810	13.77	.20	15.75	.71	.71

**Input Shaft**

Gear Frame	Version	RU	U1 <sup>6</sup>	UY1	V1	Key1
32	S2	3.17	.625	.705	1.25	3/16 Sq.
33	S2	3.17	.625	.705	1.25	3/16 Sq.
34	S2	4.75	1.125	1.236	2.25	1/4 Sq.
35	S2	5.03	1.125	1.236	2.25	1/4 Sq.

<sup>1</sup> Dimension "D" will never be exceeded, but may vary from values shown. When exact dimensions are required, shims up to .03" may be necessary.  
<sup>2</sup> All rough casting dimensions may vary by .25" due to casting variations.  
<sup>3</sup> Driven shaft entry can be from either side of the gear reducer

housing by reversing positioning of the snap rings and washer illustrated.  
<sup>4</sup> Output finished bore tolerance: +.0020", -.0000 for all diameters.  
<sup>5</sup> Output key supplied only on frame 34 in "S2" version.  
<sup>6</sup> Input shaft extension tolerances: +.0000"; -.0005" up to 1.5" diameter. Larger diameter "U1", +.000"; -.001".

## 3-Stage Finished Bore Hollow Shaft Flange Mount OtN36 - 38

OtN Series

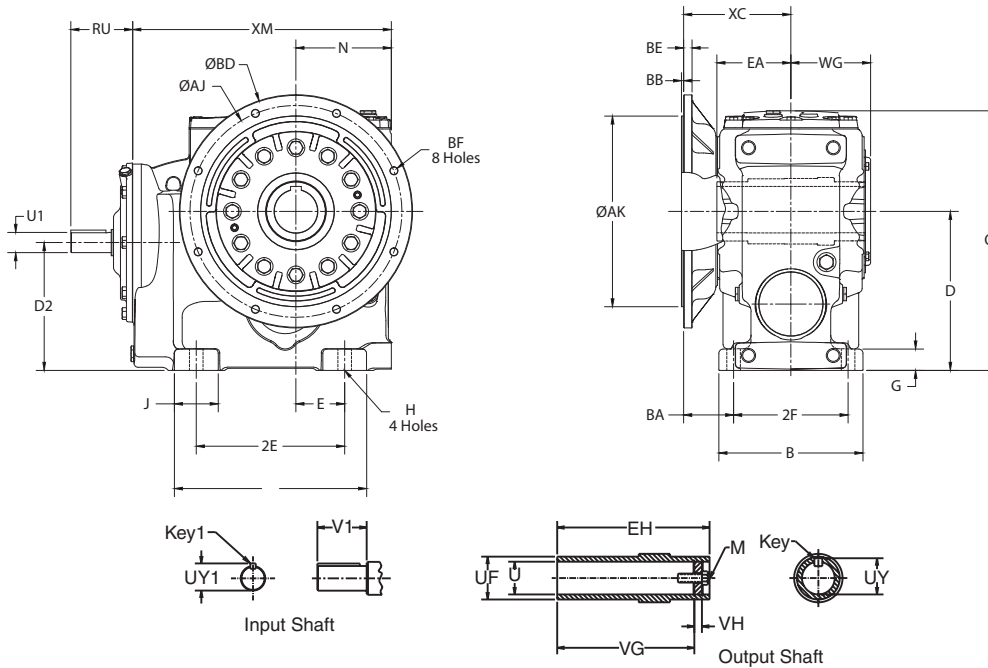

Gear Frame	Version	A	B	D <sup>1</sup>	D2	E	2E	2F	G	H	J	O	N	BA	WG	XC	XM
36	S2	17.06	11.41	8.86	8.86	6.99	13.98	9.45	1.57	.87	3.87	16.26	8.74	4.45	6.78	9.17	23.11
37	S2	20.58	12.99	9.84	10.98	8.27	16.54	10.63	1.93	.94	4.78	18.29	10.04	4.45	7.44	9.76	28.44
38	S2	17.85	13.39	14.76	11.87	4.53	13.78	10.63	1.98	1.26	4.06	24.11	8.86	4.65	7.40	9.96	24.02

### Output Shaft

Gear Frame	Version	EA	EH	U <sup>5</sup>	UF	UY	VG	VH	Key <sup>4</sup>	M
36	S2	6.22	12.44	2.750	3.93	3.037	10.89	1.23	5/8 x 5/8 x 5 1/2	3/4-10 x 2.00
37	S2	6.80	13.59	3.625	4.72	4.019	11.90	1.23	7/8 x 7/8 x 5 1/2	3/4-10 x 2.00
38	S2	6.81	13.74	4.000	5.50	4.316	11.86	.92	1 x 1 x 6 1/2	1-8 x 2.25

### Output Flange

Gear Frame	Flange Code	AJ	AK	BB	BD	BE	BF
36 & 37	5	13.78	15.75	.236	17.70	.79	.71
	6	17.72	19.68	.236	21.65	.63	.87
38	5	17.72	19.69	.200	21.65	.79	.69
	6	21.65	23.62	.236	25.98	.63	.87

### Input Shaft

Gear Frame	Version	RU	U1 <sup>6</sup>	UY1	V1	Key1
36	S2	7.56	1.875	2.101	3.75	1/2 Sq.
37	S2	7.56	1.875	2.101	3.75	1/2 Sq.
38	S2	7.56	1.875	2.101	3.75	1/2 Sq.

<sup>1</sup> Dimension "D" will never be exceeded, but may vary from values shown. When exact dimensions are required, shims up to .03" may be necessary.

<sup>2</sup> All rough casting dimensions may vary by .25" due to casting variations.

<sup>3</sup> Driven shaft entry can be from either side of the gear reducer

housing by reversing positioning of the snap rings and washer illustrated.

<sup>4</sup> Output key supplied only on frame 34 in "S2" version.

<sup>5</sup> Output finished bore tolerance: +.0020", -.0000 for all diameters.

<sup>6</sup> Input shaft extension tolerances: +.0000"; -.0005" up to 1.5" diameter. Larger diameter "U1", +.000"; -.001".

## Combined Finished Bore Hollow Shaft Flange Mount OtN32 - 35

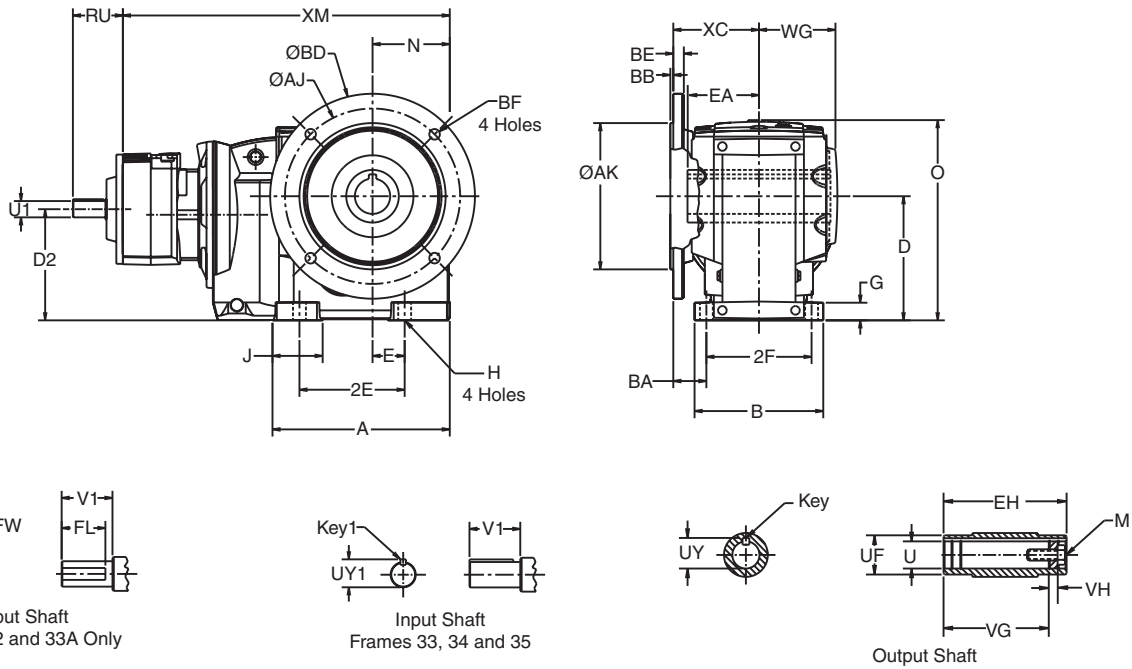

Gear Frame	Version	A	B	D <sup>1</sup>	D2	E	2E	2F	G	H	J	O	N	BA	WG	XC	XM
32	S2	7.81	5.71	4.41	4.06	1.38	5.12	4.71	.73	.43	2.34	8.09	3.03	1.81	3.22	4.04	14.49
33,33A	S2	8.50	6.61	5.51	4.91	1.18	4.72	5.51	.85	.55	2.86	9.69	3.54	2.08	3.73	4.84	19.90 <sup>7</sup>
34	S2	10.13	7.87	7.09	5.57	1.57	5.91	6.50	1.07	.71	2.67	12.05	4.49	1.93	4.66	5.18	21.55
35	S2	11.92	8.66	8.35	6.56	2.17	7.09	7.09	1.18	.87	3.45	13.58	5.20	2.22	5.15	5.77	23.87

### Output Shaft

Gear Frame	Version	EA	EH	U <sup>5</sup>	UF	UY	VG	VH	Key <sup>4</sup>	M
32	S2	2.98	5.95	1.375	1.96	1.523	5.20	.55	5/16 X 5/16 X 1 13/16	1/2-13 X 1.00
33,33A	S2	3.47	6.94	1.500	2.16	1.674	5.96	.55	3/8 X 3/8 X 2 1/4	5/8-11 X 1.75
34	S2	4.49	8.97	2.000	2.56	2.210	7.44	.79	1/2 X 7/16 X 2 5/8	5/8-11 X 1.75
35	S2	4.83	9.66	2.375	3.54	2.656	8.15	.94	5/8 X 5/8 X 3 5/8	3/4-10 X 2.00

### Output Flange

Gear Frame	Flange Code	AK	AJ	BB	BD	BE	BF
32	5	5.118	6.50	.14	7.87	.39	.47
	6	7.087	8.46	.16	9.84	.47	.55
33,33A	5	7.087	8.46	.16	9.84	.47	.55
	6	9.055	10.43	.16	11.81	.47	.55
34	5	9.055	10.43	.16	11.81	.59	.55
	6	9.842	11.80	.16	13.77	.59	.71
35	5	9.842	11.80	.20	13.77	.71	.71
	6	11.810	13.77	.20	15.75	.71	.71

### Input Shaft

Gear Frame	Version	RU	U1 <sup>6</sup>	FL	FW	UY1	V1	Key1
32,33A	S2	3.60	.500	.86	.46	-	1.00	-
33	S2	3.17	.625	-	-	.705	1.25	3/16 Sq.
34	S2	3.17	.625	-	-	.705	1.25	3/16 Sq.
35	S2	3.17	.625	-	-	.705	1.25	3/16 Sq.

<sup>1</sup> Dimension "D" will never be exceeded, but may vary from values shown. When exact dimensions are required, shims up to .03" may be necessary.  
<sup>2</sup> All rough casting dimensions may vary by .25" due to casting variations.  
<sup>3</sup> Driven shaft entry can be from either side of the gear reducer housing by reversing positioning of the snap rings and washer illustrated.  
<sup>4</sup> Output key supplied only on frame 34 in "S2" version.  
<sup>5</sup> Output finished bore tolerance: +.0020", -.0000 for all diameters.  
<sup>6</sup> Input shaft extension tolerances: +.0000"; -.0005" up to 1.5" diameter. Larger diameter "U1", +.000"; -.001".  
<sup>7</sup> XM dimension when gear frame 33A is used will be 16.42.



## Combined Finished Bore Hollow Shaft Flange Mount OtN36 - 38

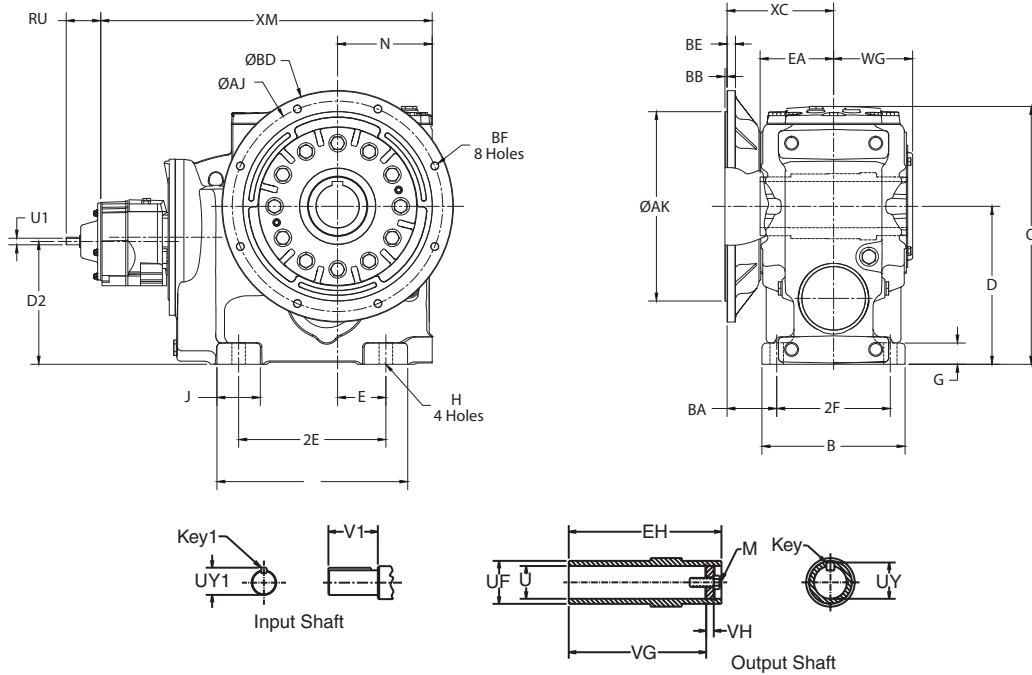

OtN Series

Gear Frame	Version	A	B	D <sup>1</sup>	D2	E	2E	2F	G	H	J	O	N	BA	WG	XC	XM
36	S2	17.06	11.41	8.86	8.46	6.99	13.98	9.45	1.57	.87	3.87	16.26	8.74	4.45	6.78	9.17	30.10
37	S2	20.58	12.99	9.84	10.57	8.27	16.54	10.63	1.93	.94	4.78	18.29	10.04	4.45	7.44	9.76	35.43
38	S2	17.85	13.39	14.76	11.48	4.53	13.78	10.63	1.98	1.26	4.06	24.11	8.86	4.65	7.40	9.96	31.00

### Output Shaft

Gear Frame	Version	EA	EH	U <sup>5</sup>	UF	UY	VG	VH	Key <sup>4</sup>	M
36	S2	6.22	12.44	2.750	3.93	3.037	10.89	1.23	5/8 x 5/8 x 5 1/2	3/4-10 x 2.00
37	S2	6.80	13.59	3.625	4.72	4.019	11.90	1.23	7/8 x 7/8 x 5 1/2	3/4-10 x 2.00
38	S2	6.81	13.74	4.000	5.50	4.316	11.86	.92	1 x 1 x 6 1/2	1-8 x 2.25

### Output Flange

Gear Frame	Flange Code	AJ	AK	BB	BD	BE	BF
36 & 37	5	13.78	15.75	.236	17.70	.79	.71
	6	17.72	19.68	.236	21.65	.63	.87
38	5	17.72	19.69	.200	21.65	.79	.69
	6	21.65	23.62	.236	25.98	.63	.87

### Input Shaft

Gear Frame	Version	RU	U1 <sup>6</sup>	UY1	V1	Key1
36	S2	3.17	.625	.714	1.25	3/16 Sq.
37	S2	3.17	.625	.714	1.25	3/16 Sq.
38	S2	3.17	.625	.714	1.25	3/16 Sq.

<sup>1</sup> Dimension "D" will never be exceeded, but may vary from values shown. When exact dimensions are required, shims up to .03" may be necessary.

<sup>2</sup> All rough casting dimensions may vary by .25" due to casting variations.

<sup>3</sup> Driven shaft entry can be from either side of the gear reducer

housing by reversing positioning of the snap rings and washer illustrated.

<sup>4</sup> Output key supplied only on frame 34 in "S2" version.

<sup>5</sup> Output finished bore tolerance: +.0020", -.0000 for all diameters.

<sup>6</sup> Input shaft extension tolerances: +.0000"; -.0005" up to 1.5" diameter. Larger diameter "U1", +.000"; -.001".

## 2-Stage Bushed Shaft Mount OtN31 - 32

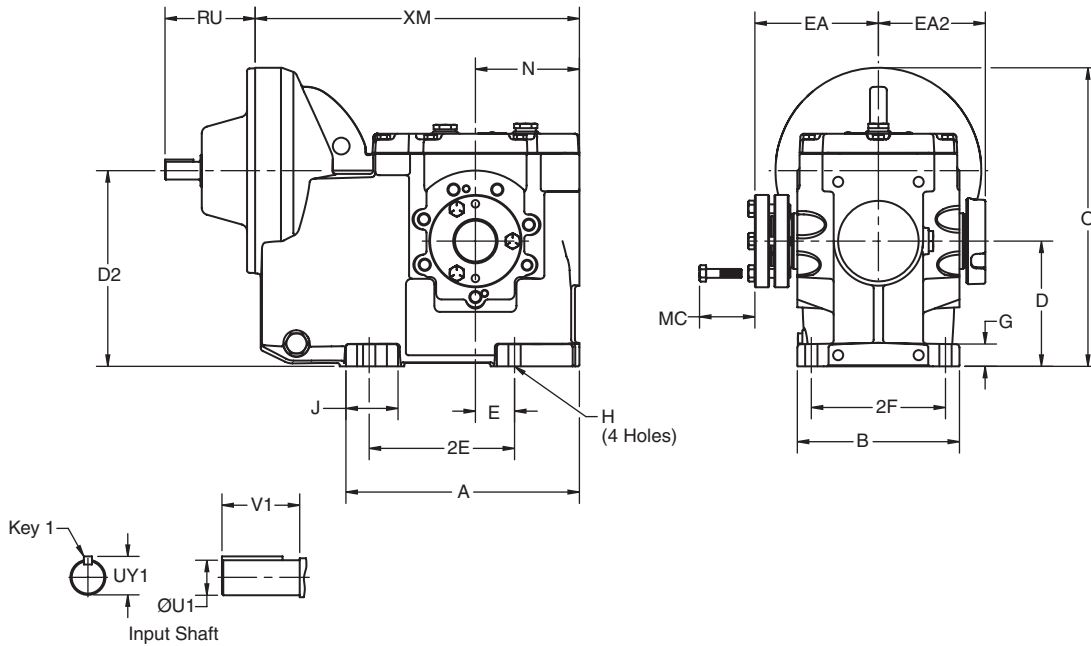

OtN Series

Gear Frame	Version	A	B	D <sup>1</sup>	D2	E	2E	2F	G	H	J	O	N	XM
3132	S2	5.88	4.65	3.15	4.98	1.97	3.94	3.94	.56	.35	1.53	8.01	3.15	10.59
3242	S2	8.22	5.71	4.41	6.89	1.38	5.12	4.72	.79	.43	1.83	10.51	3.66	12.36

### Output Shaft

Gear Frame	Version	EA	EA2	MC <sup>5</sup>	Bushing Bores <sup>4</sup>	
					Min.	Max.
3132	S2	4.25	3.80	1.50	1	1 5/16
3242	S2	4.85	4.27	1.75	3/4	1 7/16

### Input Shaft

Gear Frame	Version	RU	U1 <sup>3</sup>	UY1	V1	Key1
31	S2	3.17	.625	.705	1.25	3/16 Sq.
32	S2	3.17	.625	.705	1.25	3/16 Sq.

<sup>1</sup> Dimension "D" will never be exceeded, but may vary from values shown. When exact dimensions are required, shims up to .03" may be necessary.

<sup>2</sup> All rough casting dimensions may vary by .25" due to casting variations.

<sup>3</sup> Input shaft extension tolerances: +.0000"; -.0005" up to 1.5" diameter. Larger diameter "U1", +.000"; -.001".

<sup>4</sup> Refer to page B-132 by gear frame for listing of all inch and metric bushing bore sizes available.

<sup>5</sup> The MC dimension shows spacing required to install or remove the bushing from the reducer.

<sup>6</sup> Bushing and dust cap can be installed opposite of how they are shown above.

<sup>7</sup> Driven shaft entry can be from either side of the gear reducer housing. Refer to installation manual for requirements.

<sup>8</sup> For details of the torque arm kit, refer to page B-129.

## 3-Stage Taper Bushed Shaft Mount OtN32 - 38

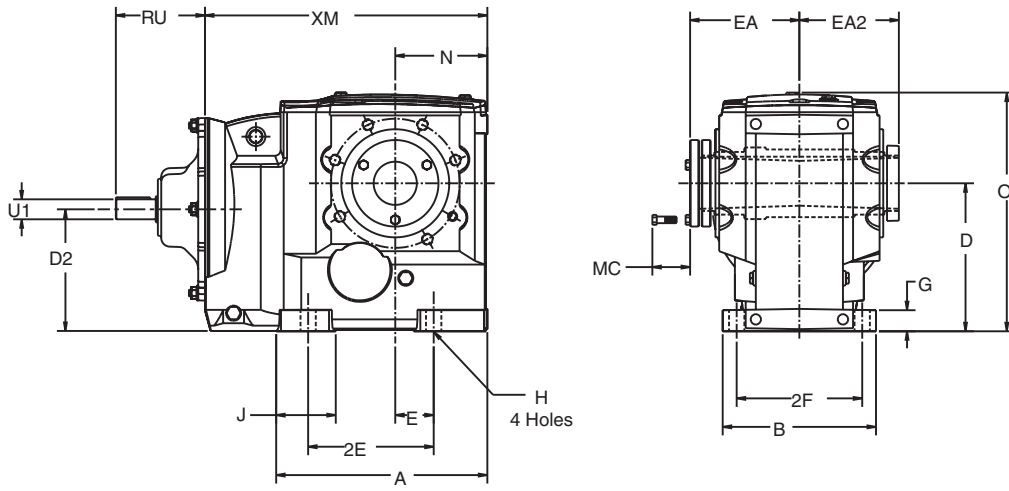

Input Shaft

Gear Frame	Version	A	B	D <sup>1</sup>	D2	E	2E	2F	G	H	J	O	N	XM
32	S2	7.81	5.71	4.41	3.78	1.38	5.12	4.71	.73	.43	2.34	8.09	3.03	10.04
34	S2	10.13	7.87	7.09	5.90	1.57	5.91	6.50	1.07	.71	2.67	12.05	4.49	13.78
35	S2	11.92	8.66	8.35	6.89	2.17	7.09	7.09	1.18	.87	3.45	13.58	5.20	15.95
36	S2	17.06	11.41	8.86	8.86	6.99	13.98	9.45	1.57	.87	3.87	16.26	8.74	23.11
37	S2	20.58	12.99	9.84	10.98	8.27	16.54	10.63	1.93	.94	4.78	18.29	10.04	28.44
38	S2	17.85	13.39	14.76	11.87	4.53	13.78	10.63	1.98	1.26	4.06	24.11	8.86	24.02

### Output Shaft

Gear Frame	Version	EA	EA2	MC <sup>5</sup>	Bushing Bores <sup>4</sup>	
					Min.	Max.
32	S2	4.85	4.27	1.75	3/4	1 7/16
34	S2	5.84	5.27	1.88	15/16	1 15/16
35	S2	6.17	5.620	1.88	1 3/8	2 7/16
36	S2	6.81	7.83	1.88	2 7/16	2 15/16
37	S2	9.50	8.86	2.25	2 7/8	3 7/16
38	S2	8.66	8.08	2.75	2 15/16	3 15/16

### Input Shaft

Gear Frame	Version	RU	U1 <sup>3</sup>	UY1	V1	Key1
32	S2	3.17	.625	.705	1.25	3/16 Sq.
34	S2	4.75	1.125	1.236	2.25	1/4 Sq.
35	S2	5.03	1.125	1.236	2.25	1/4 Sq.
36	S2	7.56	1.875	2.101	3.75	1/2 Sq.
37	S2	7.56	1.875	2.101	3.75	1/2 Sq.
38	S2	7.56	1.875	2.101	3.75	1/2 Sq.

<sup>1</sup> Dimension "D" will never be exceeded, but may vary from values shown. When exact dimensions are required, shims up to .03" may be necessary.  
<sup>2</sup> All rough casting dimensions may vary by .25" due to casting variations.  
<sup>3</sup> Input shaft extension tolerances: +.0000"; -.0005" up to 1.5" diameter. Larger diameter "U1", +.000"; -.001".  
<sup>4</sup> Refer to page B-133 by gear frame for listing of all inch and metric

bushing bore sizes available.  
<sup>5</sup> The MC dimension shows spacing required to install or remove the bushing from the reducer.  
<sup>6</sup> Bushing and dust cap can be installed opposite of how they are shown above.  
<sup>7</sup> Driven shaft entry can be from either side of the gear reducer housing. Refer to installation manual for requirements.  
<sup>8</sup> For details of the torque arm kit, refer to page B-129.

## Combined Taper Bushed Shaft Mount OtN32 - 38

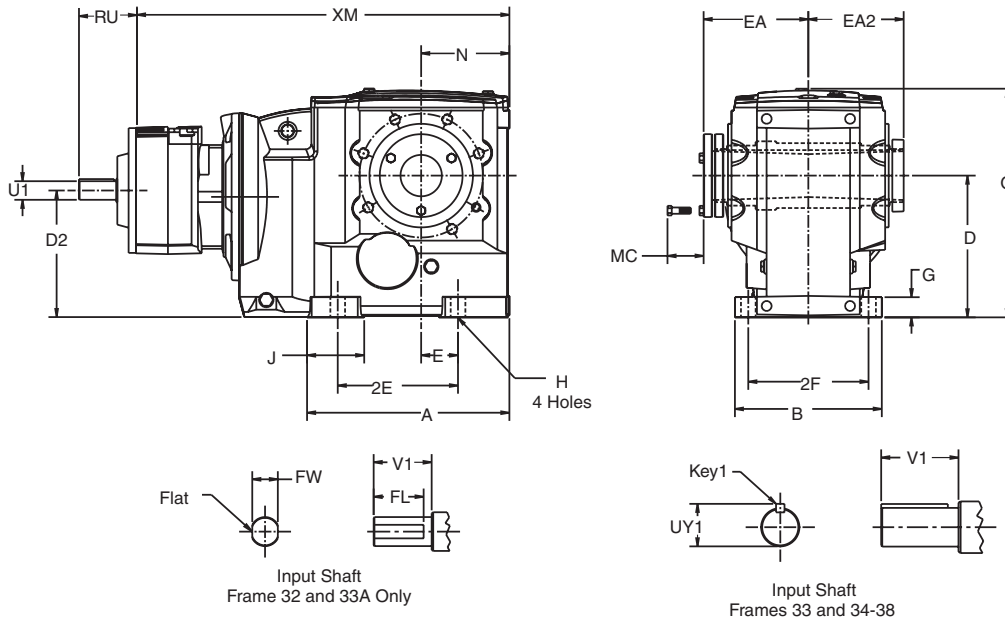

# OtN Series

Gear Frame	Version	A	B	D <sup>1</sup>	D2	E	2E	2F	G	H	J	O	N	XM
32	S2	7.81	5.71	4.41	4.06	1.38	5.12	4.71	.73	.43	2.34	8.09	3.03	14.49
33, 33A	S2	8.50	6.61	5.51	4.91	1.18	4.72	5.51	.85	.55	2.86	9.69	3.54	19.99
34	S2	10.13	7.87	7.09	5.57	1.57	5.91	6.50	1.07	.71	2.67	12.05	4.49	21.55
35	S2	11.92	8.66	8.35	6.56	2.17	7.09	7.09	1.18	.87	3.45	13.58	5.20	23.87
36	S2	17.06	11.41	8.86	8.46	6.99	13.98	9.45	1.57	.87	3.87	16.26	8.74	30.10
37	S2	20.58	12.99	9.84	10.57	8.27	16.54	10.63	1.93	.94	4.78	18.29	10.04	35.43
38	S2	17.85	13.39	14.76	11.48	4.53	13.78	10.63	1.98	1.26	4.06	24.11	8.86	31.00

### Output Shaft

Gear Frame	Version	EA	EA2	MC <sup>5</sup>	Bushing Bores <sup>4</sup>	
					Min.	Max.
32	S2	4.85	4.27	1.75	1 5/16	1 7/16
33	S2	4.82	4.23	1.75	1 5/16	1 7/16
33A	S2	5.76	5.18	1.88	1 7/16	1 15/16
34	S2	5.84	5.27	1.88	15/16	1 15/16
35	S2	6.17	5.620	1.88	1 3/8	2 7/16
36	S2	6.81	7.83	1.88	2 7/16	2 15/16
37	S2	9.50	8.86	2.25	2 7/8	3 7/16
38	S2	8.66	8.08	2.75	2 15/16	3 15/16

### Input Shaft

Gear Frame	Version	RU	U1 <sup>3</sup>	FL	FW	UY1	V1	Key1
32, 33A	S2	3.60	.500	.86	.46	-	1.00	-
33	S2	3.17	.625	-	-	.705	1.25	3/16 Sq.
34	S2	3.17	.625	-	-	.705	1.25	3/16 Sq.
35	S2	3.17	.625	-	-	.705	1.25	3/16 Sq.
36	S2	3.17	.625	-	-	.714	1.25	3/16 Sq.
37	S2	3.17	.625	-	-	.714	1.25	3/16 Sq.
38	S2	3.17	.625	-	-	.714	1.25	3/16 Sq.

<sup>1</sup> Dimension "D" will never be exceeded, but may vary from values shown. When exact dimensions are required, shims up to .03" may be necessary.

<sup>2</sup> All rough casting dimensions may vary by .25" due to casting variations.

<sup>3</sup> Input shaft extension tolerances: +.0000"; -.0005" up to 1.5" diameter. Larger diameter "U1", +.000"; -.001".

<sup>4</sup> Refer to page B-133 by gear frame for listing of all inch and metric bushing bore sizes available.

<sup>5</sup> The MC dimension shows spacing required to install or remove the bushing from the reducer.

<sup>6</sup> Bushing and dust cap can be installed opposite of how they are shown above.

<sup>7</sup> Driven shaft entry can be from either side of the gear reducer housing. Refer to installation manual for requirements.

<sup>8</sup> For details of the torque arm kit, refer to page B-129.

<sup>9</sup> XM dimension when gear frame 33A is used will be 16.42.

## 2-Stage CEMA Screw Conveyor Drive OtN32

OtN Series

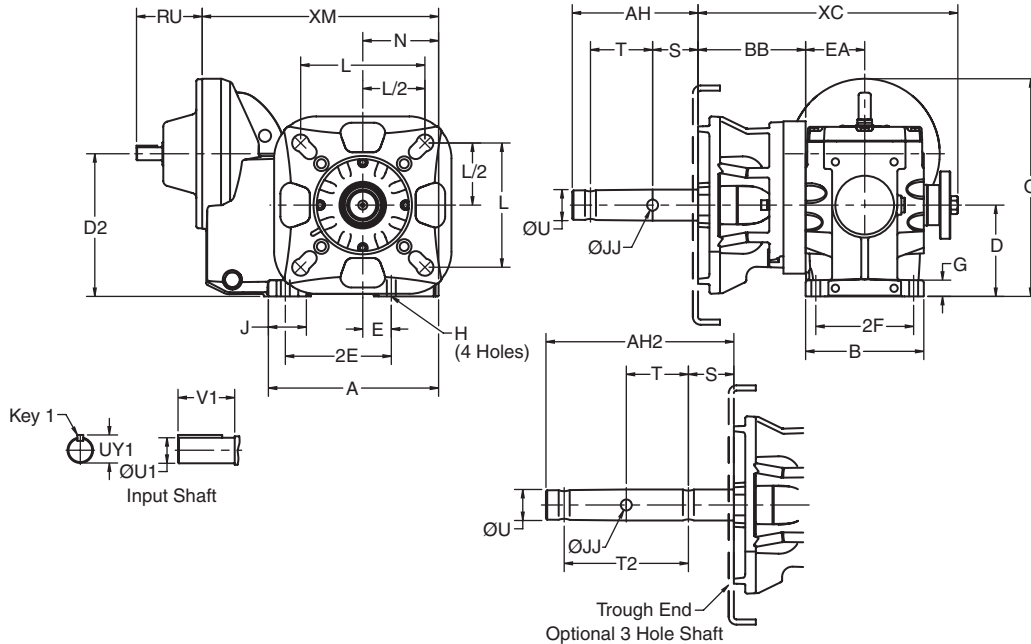

Gear Frame	Version	A	B	D <sup>1</sup>	D2	E	2E	2F	G	H	J	O	N	EA	XC	XM
3242	S2	8.22	5.71	4.41	6.89	1.38	5.12	4.72	.79	.43	1.83	10.51	3.66	2.85	7.35	12.36

### Output Shaft

Gear Frame	Screw Dia.	JJ	L	U	S	T	T2	AH	AH2	BB
3242	6-10	.53	4.00	1.50	2.13	3.00	6.00	6.00	9.00	5.13
	9-12	.66	5.13	2.00	2.13	3.00	6.00	6.00	9.00	5.13
	12-14	.66	5.63	2.44	2.75	3.00	6.00	6.00	9.69	5.13
	12-20	.78	6.00	3.00	2.88	3.00	6.00	6.88	9.88	5.13

### Input Shaft

Gear Frame	Version	RU	U1 <sup>5</sup>	UY1	V1	Key1
32	S2	3.17	.625	.705	1.25	3/16 Sq.

<sup>1</sup> Dimension "D" will never be exceeded, but may vary from values shown. When exact dimensions are required, shims up to .03" may be necessary.

<sup>2</sup> All rough casting dimensions may vary by .25" due to casting variations.

<sup>3</sup> Refer to pages B-131 and B-132 for the screw conveyor drive shafts, trough ends and other accessories available for each gear frame size.

<sup>4</sup> Thrust ratings for each gear frame size are listed on page B-131.

<sup>5</sup> Input shaft extension tolerance (U1): +.0000"/-.0005" up to 1.5" diameter; larger diameters +.000"; -.001".

## 3-Stage CEMA Screw Conveyor Drive OtN32 - 33

# OtN Series

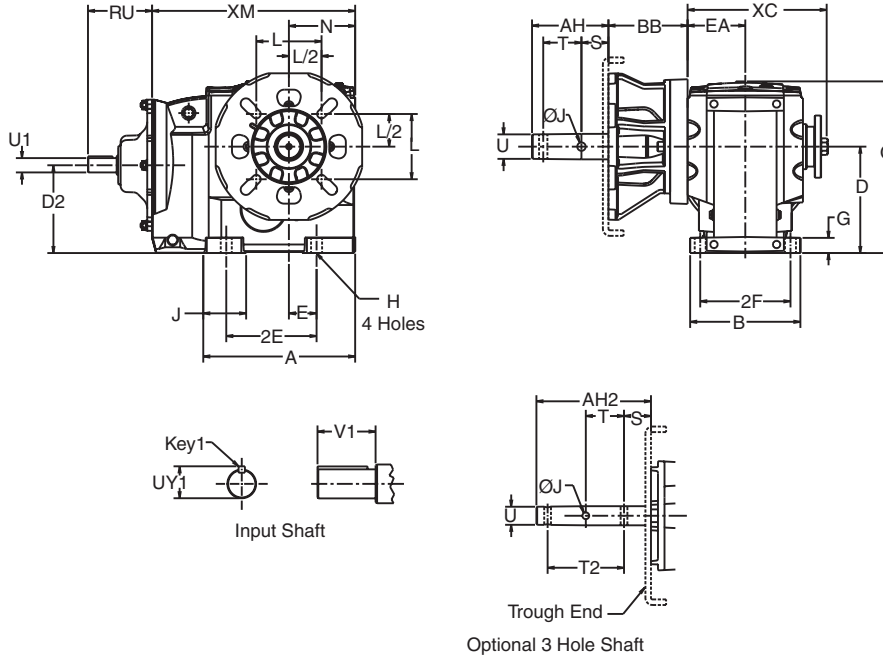

Gear Frame	Version	A	B	D <sup>1</sup>	D2	E	2E	2F	G	H	J	O	N	EA	XC	XM
32	S2	7.81	5.71	4.41	3.78	1.38	5.12	4.71	.73	.43	2.34	8.09	3.03	2.85	7.35	10.84
33	S2	8.50	6.61	5.51	5.24	1.18	4.72	5.51	.85	.55	2.86	9.69	3.54	3.35	8.30	11.97
34	S2	10.13	7.87	7.09	5.90	1.57	5.91	6.50	1.07	.71	2.67	12.05	4.49	4.07	9.84	13.78
35	S2	11.92	8.66	8.35	6.89	2.17	7.09	7.09	1.18	.87	3.37	13.58	5.20	4.43	11.00	15.95

### Screw Conveyor

Gear Frame	Screw Dia.	J	L	U	S	T	T2	AH	AH2	BB
32,33	6 - 10	.53	4.00	1.50	2.13	3.00	6.00	6.00	9.00	5.13
	9 - 12	.66	5.13	2.00	2.13	3.00	6.00	6.00	9.00	5.13
	12 - 14	.66	5.63	2.44	2.75	3.00	6.00	6.00	9.69	5.13
	12 - 20	.78	6.00	3.00	2.88	3.00	6.00	6.88	9.88	5.13
34	6 - 10	.53	4.00	1.50	2.13	3.00	6.00	6.00	9.00	5.13
	9 - 12	.66	5.13	2.00	2.13	3.00	6.00	6.00	9.00	5.13
	12 - 14	.66	5.63	2.44	2.75	3.00	6.00	6.00	9.69	5.13
	12 - 20	.78	6.00	3.00	2.88	3.00	6.00	6.88	9.88	5.13
35	9 - 12	.66	5.13	2.00	2.13	3.00	6.00	6.00	9.00	6.21
	12 - 14	.66	5.63	2.44	2.75	3.00	6.00	6.69	9.69	6.21
	12 - 20	.78	6.00	3.00	2.88	3.00	6.00	6.88	9.88	6.21
	18 - 24	.91	6.75	3.44	3.88	4.00	-	9.13	-	6.21

Gear Frame	Version	RU	U1 <sup>5</sup>	UY1	V1	Key1
32	S2	3.17	.625	.705	1.25	3/16 Sq.
33	S2	3.17	.625	.705	1.25	3/16 Sq.
34	S2	4.75	1.125	1.236	2.25	1/4 Sq.
35	S2	5.03	1.125	1.236	2.25	1/4 Sq.

<sup>1</sup> Dimension "D" will never be exceeded, but may vary from values shown. When exact dimensions are required, shims up to .03" may be necessary.

<sup>2</sup> All rough casting dimensions may vary by .25" due to casting variations.

<sup>3</sup> Refer to pages B-131 and B-132 for the screw conveyor drive shafts, trough ends and other accessories available for each gear frame size.

<sup>4</sup> Thrust ratings for each gear frame size are listed on page B-131.

<sup>5</sup> Input shaft extension tolerance (U1): +.0000"/-.0005" up to 1.5" diameter; larger diameters +.000"; -.001".

## 3-Stage CEMA Screw Conveyor Drive OtN36-37

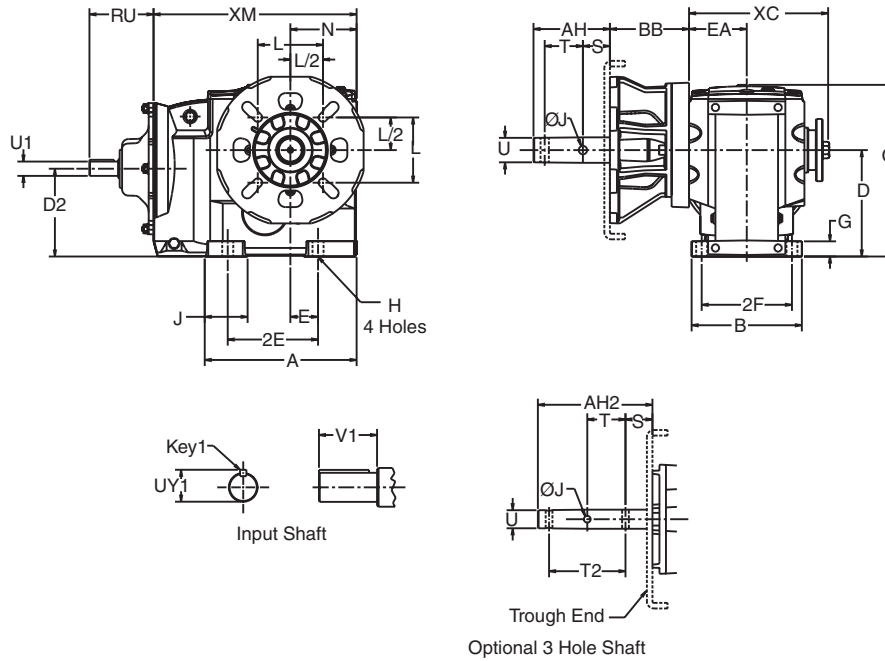

Gear Frame	Version	A	B	D <sup>1</sup>	D2	E	2E	2F	G	H	J	O	N	EA	XC	XM
36	S2	17.06	11.41	8.86	8.86	6.99	13.98	9.45	1.57	.87	3.87	16.26	8.74	6.02	13.14	23.11
37	S2	20.58	12.99	9.84	10.98	8.27	16.54	10.63	1.93	.94	4.78	18.29	10.04	6.61	14.76	28.44

### Screw Conveyor

Gear Frame	Screw Dia.	JJ	L	U	S	T	T2	AH	AH2	BB
36	9-12	.66	5.13	2.00	2.13	3.00	6.00	6.00	9.00	6.67
	12, 14	.66	5.63	2.44	2.75	3.00	6.00	6.69	9.69	6.67
	12-20	.78	6.00	3.00	2.88	3.00	6.00	6.88	9.88	6.67
	18-24	.91	6.75	3.44	3.88	4.00	8.00	9.13	13.13	6.67
37	12-20	.78	6.00	3.00	2.88	3.00	6.00	6.88	9.88	7.94
	18-24	.91	6.75	3.44	3.88	4.00	8.00	9.13	13.13	7.94

### Input Shaft

Gear Frame	Version	RU	U1 <sup>5</sup>	UY1	V1	Key1
36	S2	7.56	1.875	2.101	3.75	1/2 Sq.
37	S2	7.56	1.875	2.101	3.75	1/2 Sq.

<sup>1</sup> Dimension "D" will never be exceeded, but may vary from values shown. When exact dimensions are required, shims up to .03" may be necessary.

<sup>2</sup> All rough casting dimensions may vary by .25" due to casting variations.

<sup>3</sup> Refer to pages B-131 and B-132 for the screw conveyor drive shafts, trough ends and other accessories available for each gear frame size.

<sup>4</sup> Thrust ratings for each gear frame size are listed on page B-131.

<sup>5</sup> Input shaft extension tolerance (U1): +.0000"/-.0005" up to 1.5" diameter; larger diameters +.000"; -.001".



## Combined CEMA Screw Conveyor Drive OtN32 - 35

# OtN Series

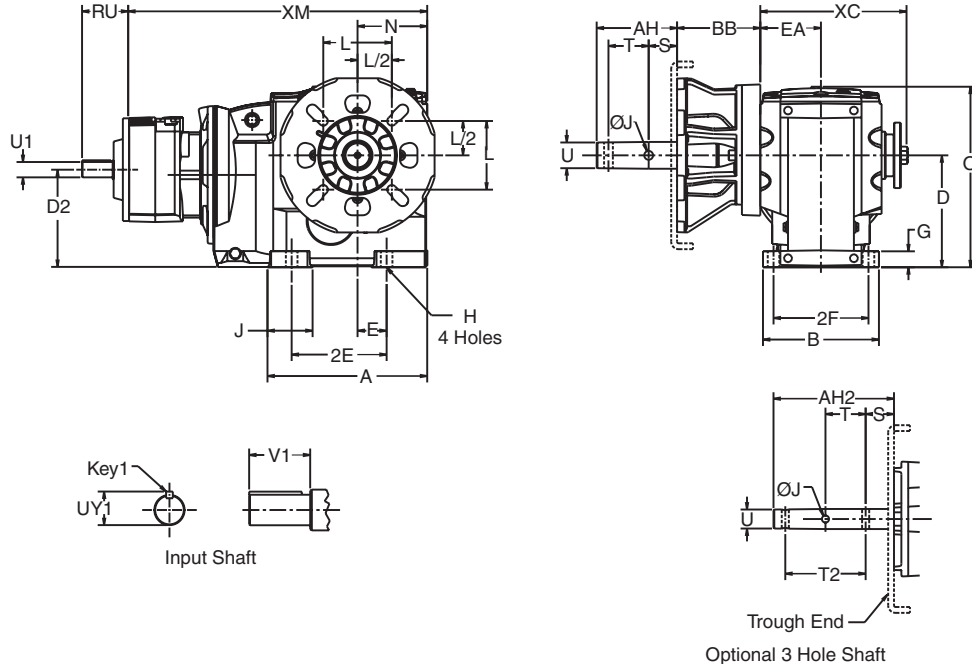

Gear Frame	Version	A	B	D <sup>1</sup>	D2	E	2E	2F	G	H	J	O	N	EA	XC	XM
32	S2	7.81	5.71	4.41	4.06	1.38	5.12	4.71	.73	.43	2.34	8.09	3.03	2.85	7.35	14.49
33, 33A	S2	8.50	6.61	5.51	4.91	1.18	4.72	5.51	.85	.55	2.86	9.69	3.54	3.35	8.30	19.90 <sup>5</sup>
34	S2	10.13	7.87	7.09	4.87	1.57	5.91	6.50	1.07	.71	2.67	12.05	4.49	4.07	9.84	21.55
35	S2	11.92	8.66	8.35	5.57	2.17	7.09	7.09	1.18	.87	3.37	13.58	5.20	4.43	11.00	23.87

### Screw Conveyor

Gear Frame	Screw Dia.	J	L	U	S	T	T2	AH	AH2	BB
32, 33, 33A	6 - 10	.53	4.00	1.50	2.13	3.00	6.00	6.00	9.00	5.13
	9 - 12	.66	5.13	2.00	2.13	3.00	6.00	6.00	9.00	5.13
	12 - 14	.66	5.63	2.44	2.75	3.00	6.00	6.00	9.69	5.13
	12 - 20	.78	6.00	3.00	2.88	3.00	6.00	6.88	9.88	5.13
34	6 - 10	.53	4.00	1.50	2.13	3.00	6.00	6.00	9.00	5.13
	9 - 12	.66	5.13	2.00	2.13	3.00	6.00	6.00	9.00	5.13
	12 - 14	.66	5.63	2.44	2.75	3.00	6.00	6.00	9.69	5.13
	12 - 20	.78	6.00	3.00	2.88	3.00	6.00	6.88	9.88	5.13
35	9 - 12	.66	5.13	2.00	2.13	3.00	6.00	6.00	9.00	6.21
	12 - 14	.66	5.63	2.44	2.75	3.00	6.00	6.69	9.69	6.21
	12 - 20	.78	6.00	3.00	2.88	3.00	6.00	6.88	9.88	6.21
	18 - 24	.91	6.75	3.44	3.88	4.00	-	9.13	-	6.21

Gear Frame	Version	RU	U1 <sup>6</sup>	FL	FW	UY1	V1	Key1
32, 33A	S2	2.92	.500	.86	.46	-	1.00	-
33	S2	3.17	.625	-	-	.705	1.25	3/16 Sq.
34	S2	3.17	.625	-	-	.705	1.25	3/16 Sq.
35	S2	3.17	.625	-	-	.705	1.25	3/16 Sq.

<sup>1</sup> Dimension "D" will never be exceeded, but may vary from values shown. When exact dimensions are required, shims up to .03" may be necessary.

<sup>2</sup> All rough casting dimensions may vary by .25" due to casting variations.

<sup>3</sup> Refer to pages B-131 and B-132 for the screw conveyor drive shafts,

trough ends and other accessories available for each gear frame size.

<sup>4</sup> Thrust ratings for each gear frame size are listed on page B-131.

<sup>5</sup> XM dimension is 16.42 for gear frame 33A.

<sup>6</sup> Input shaft extension tolerance (U1): +.0000"/-.0005" up to 1.5" diameter; larger diameters +.000"; -.001".

## Combined CEMA Screw Conveyor Drive OtN36 - 37

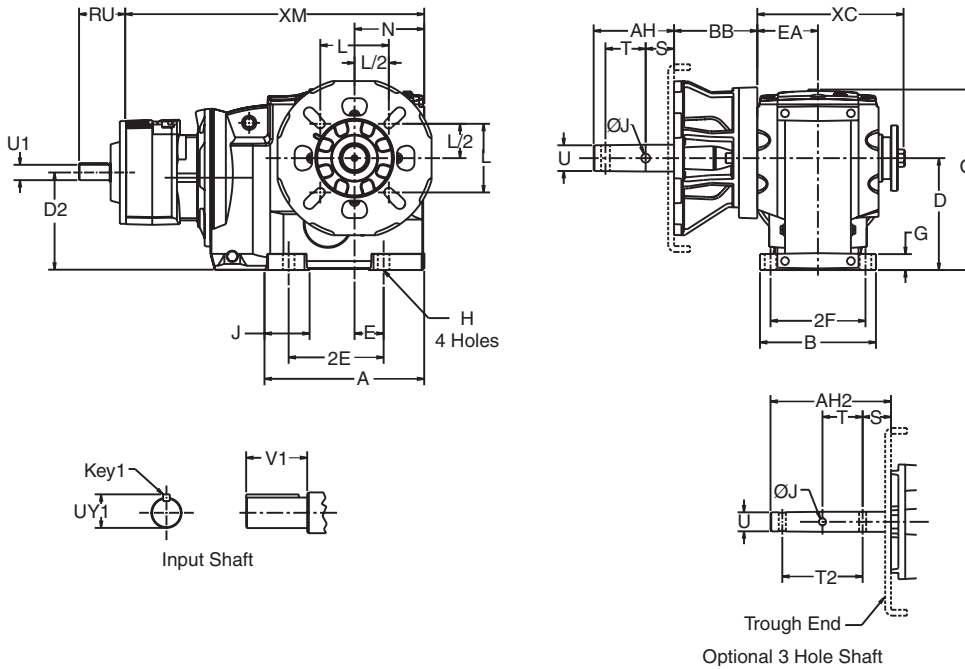

Gear Frame	Version	A	B	D <sup>1</sup>	D2	E	2E	2F	G	H	J	O	N	EA	XC	XM
36	S2	17.06	11.41	8.86	8.46	6.99	13.98	9.45	1.57	.87	3.87	16.26	8.74	6.02	13.14	30.10
37	S2	20.58	12.99	9.84	10.57	8.27	16.54	10.63	1.93	.94	4.78	18.29	10.04	6.61	14.76	35.43

### Screw Conveyor

Gear Frame	Screw Dia.	JJ	L	U	S	T	T2	AH	AH2	BB
36	9-12	.66	5.13	2.00	2.13	3.00	6.00	6.00	9.00	6.67
	12, 14	.66	5.63	2.44	2.75	3.00	6.00	6.69	9.69	6.67
	12-20	.78	6.00	3.00	2.88	3.00	6.00	6.88	9.88	6.67
	18-24	.91	6.75	3.44	3.88	4.00	8.00	9.13	13.13	6.67
37	12-20	.78	6.00	3.00	2.88	3.00	6.00	6.88	9.88	7.94
	18-24	.91	6.75	3.44	3.88	4.00	8.00	9.13	13.13	7.94

### Input Shaft

Gear Frame	RU	U1	UY1	V1	Key1
36	3.17	.625	.714	1.25	3/16 Sq.
37	3.17	.625	.714	1.25	3/16 Sq.

<sup>1</sup> Dimension "D" will never be exceeded, but may vary from values shown. When exact dimensions are required, shims up to .03" may be necessary.

<sup>2</sup> All rough casting dimensions may vary by .25" due to casting variations.

<sup>3</sup> Refer to pages B-131 and B-132 for the screw conveyor drive shafts, trough ends and other accessories available for each gear frame size.

<sup>4</sup> Thrust ratings for each gear frame size are listed on page B-131.

<sup>5</sup> Input shaft extension tolerance (U1): +.0000"/-.0005" up to 1.5" diameter; larger diameters +.000"; -.001".

## 3-Stage Output Shafted Foot Mount OtN33 - 35

# OtN Series

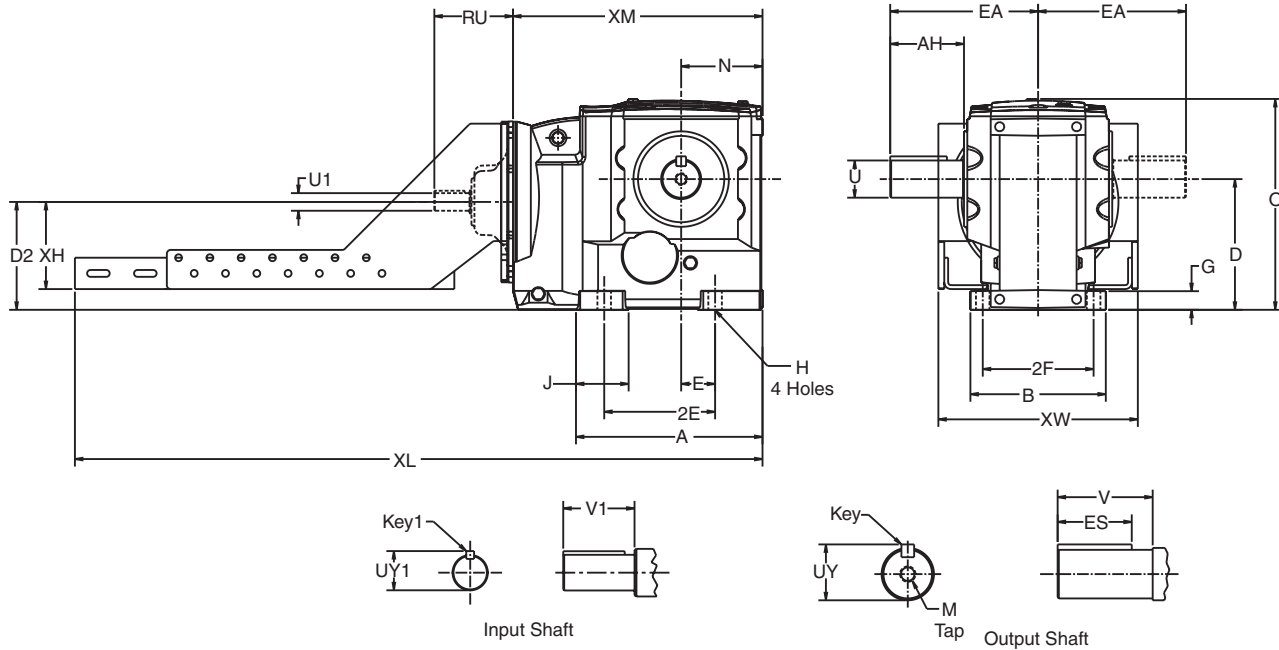

Gear Frame	Version	A	B	D <sup>1</sup>	D2	E	2E	2F	G	H	J	O	N	XM
33	S2	8.50	6.61	5.51	5.24	1.18	4.72	5.51	.85	.55	2.86	9.69	3.54	11.97
	S1	8.08	8.58	4.92	5.20	3.35	6.69	6.10	.79	.55	2.27	10.43	3.54	11.97
34	S2	10.13	7.87	7.09	5.90	1.57	5.91	6.50	1.07	.71	2.67	12.05	4.49	13.78
	S1	10.69	9.60	6.30	7.49	4.53	9.06	7.68	1.18	.71	3.19	13.39	4.49	13.78
35	S2	11.92	8.66	8.35	6.89	2.17	7.09	7.09	1.18	.87	3.37	13.58	5.20	15.95
	S1	13.07	10.98	7.87	9.33	5.51	11.02	9.06	1.40	.87	4.05	16.22	5.20	15.95

### Output Shaft

Gear Frame	Version	U <sup>3</sup>	UY	V	AH	EA	Key	ES	M
33	S2	1.625	1.783	3.25	3.39	6.73	3/8 Sq.	2.78	5/8-11 X 1.38
	S1	1.500	1.657	3.18	3.19	7.12	3/8 Sq.	2.78	5/8-11 X 1.38
34	S2	2.000	2.210	3.63	3.76	8.11	1/2 Sq.	3.06	3/4-10 X 1.61
	S1	1.750	1.909	3.56	3.66	8.46	3/8 Sq.	3.56	3/4-10 X 1.61
35	S2	2.375	2.638	4.61	4.74	9.45	5/8 Sq.	3.81	3/4-10 X 1.61
	S1	2.375	2.638	5.73	5.27	10.57	5/8 Sq.	4.81	3/4-10 X 1.61

### Input Shaft

Gear Frame	Version	RU	U1 <sup>4</sup>	UY1	V1	Key1
33	S1,S2	3.17	.625	.71	1.25	3/16 Sq.
34	S1,S2	4.75	1.125	1.236	2.25	1/4 Sq.
35	S1,S2	5.03	1.125	1.236	2.25	1/4 Sq.

### Motor Frame

Gear Frame	143T-145T			182T-184T			213T-215T		
	XH	XL	XW	XH	XL	XW	XH	XL	XW
33	3.75	30.25	11.38	-	-	-	-	-	-
34	4.74	39.25	12.38	4.74	39.25	12.38	-	-	-
35	5.50	42.61	12.75	5.50	41.61	12.75	5.50	42.01	12.75

<sup>1</sup> Dimension "D" will never be exceeded, but may vary from values shown. When exact dimensions are required, shims up to .03" may be necessary.

<sup>2</sup> All rough casting dimensions may vary by .25" due to casting variations.

<sup>3</sup> Output shaft extension tolerances: +.0000"; -.0005" for shafts up to 1.5" diameter "U". Larger diameter "U", +.000"; -.001".

<sup>4</sup> Input shaft extension tolerances: +.0000"; -.0005" up to 1.5" diameter. Larger diameter "U1", +.000"; -.001".

## 3-Stage Output Shafted Foot Mount OtN36 - 38

OtN Series

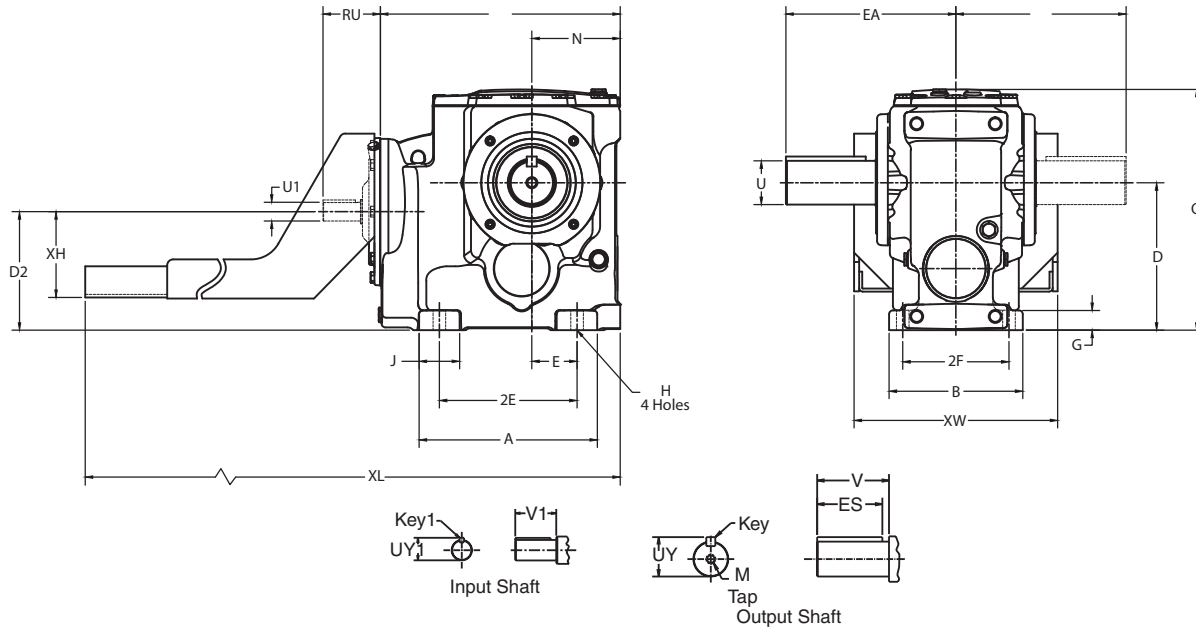

Gear Frame	Version	A	B	D <sup>1</sup>	D2	E	2E	2F	G	H	J	O	N	XM
36	S1	17.06	11.41	8.86	8.86	6.99	13.98	9.45	1.57	.87	3.87	16.26	8.74	23.12
37	S1	20.58	12.99	9.84	10.98	8.27	16.54	10.63	1.93	.94	4.78	18.29	10.04	28.44
38	S2	17.85	13.39	14.76	11.87	4.53	13.78	10.63	1.98	1.26	4.06	24.11	8.86	24.02

### Output Shaft

Gear Frame	Version	U <sup>3</sup>	UY	V	AH	EA	KEY	ES	M
36	S1	2.875	3.20	5.75	5.92	11.94	3/4 Sq.	5.00	3/4-10 x 1.61
37	S1	3.625	4.01	6.86	7.04	13.66	7/8 Sq.	6.00	1-8 x 2.13
38	S2	4.375	4.809	8.99	9.97	17.03	1.00 Sq.	7.00	1-8 x 2.25

### Input Shaft

Gear Frame	Version	RU	U1 <sup>4</sup>	UY1	V1	Key1
36	S1	7.56	1.875	2.101	3.75	1/2 Sq.
37	S1	7.56	1.875	2.101	3.75	1/2 Sq.
38	S2	7.56	1.875	2.101	3.75	1/2 Sq.

### Motor Frame

Gear Frame	182-184T			213-215T			254-256T			284T-286T			324T-326T		
	XH	XL	XW	XH	XL	XW	XH	XL	XW	XH	XL	XW	XH	XL	XW
36	6.63	55.06	15.00	6.63	55.06	15.00	6.63	55.06	15.00	8.50	59.06	19.06	8.50	59.06	19.06
37	6.63	60.4	15.00	6.63	60.4	15.00	6.63	60.4	15.00	8.50	64.4	19.06	8.50	64.4	19.06
38	-	-	-	-	-	-	8.50	59.93	19.06	8.50	58.93	19.06	9.50	60.93	21.31

<sup>1</sup> Dimension "D" will never be exceeded, but may vary from values shown. When exact dimensions are required, shims up to .03" may be necessary.

<sup>2</sup> All rough casting dimensions may vary by .25" due to casting variations.

<sup>3</sup> Output shaft extension tolerances: +.0000"; -.0005" for shafts up to 1.5" diameter "U", Larger diameter "U", +.000"; -.001".

<sup>4</sup> Input shaft extension tolerances: +.0000"; -.0005" for shafts up to 1.5" diameter. Larger diameter "U1", +.000"; -.001".

## Combined Output Shafted Foot Mount OtN36 - 38

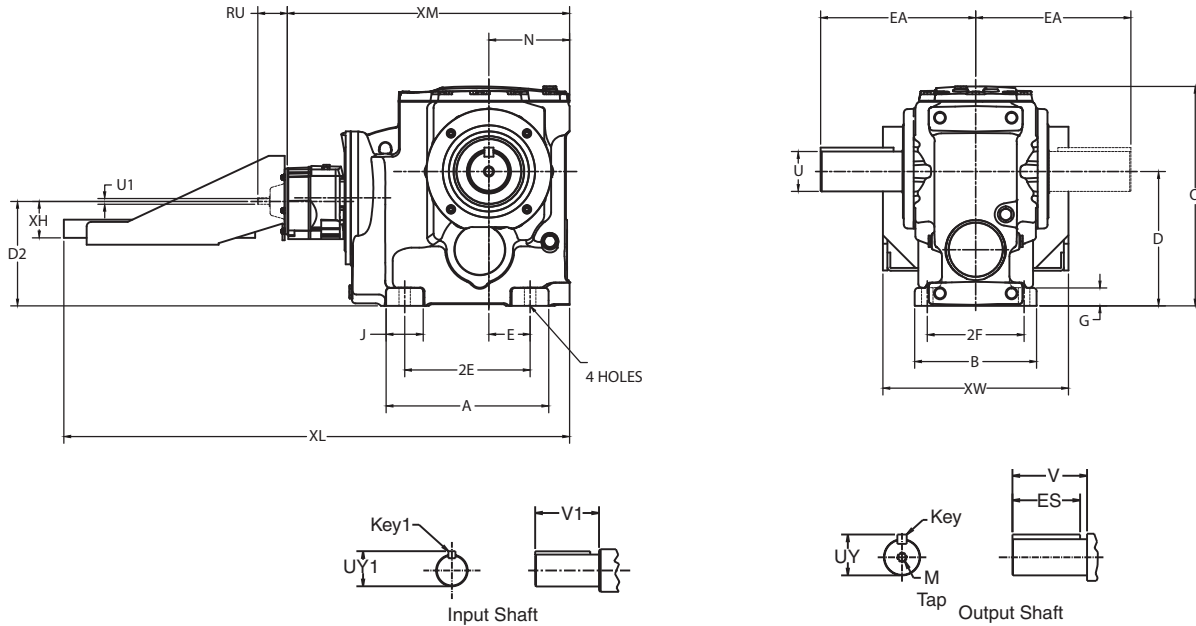

# OtN Series

Gear Frame	Version	A	B	D <sup>1</sup>	D <sub>2</sub>	E	2E	2F	G	H	J	O	N	XM
36	S1	17.06	11.41	8.86	8.46	6.99	13.98	9.45	1.57	.87	3.87	16.26	8.74	30.10
37	S1	20.58	12.99	9.84	10.57	8.27	16.54	10.63	1.93	.94	4.78	18.29	10.04	35.43
38	S2	17.85	13.39	14.76	11.48	4.53	13.78	10.63	1.98	1.26	4.06	24.11	8.86	31.00

### Output Shaft

Gear Frame	Version	U <sup>3</sup>	UY	V	AH	EA	KEY	ES	M
36	S1	2.875	3.20	5.75	5.92	11.94	3/4 Sq.	5.00	3/4-10 x 1.61
37	S1	3.625	4.01	6.86	7.04	13.66	7/8 Sq.	6.00	1-8 x 2.13
38	S2	4.375	4.809	8.99	9.97	17.03	1.00 Sq.	7.00	1-8 x 2.25

### Input Shaft

Gear Frame	Version	RU	U1 <sup>4</sup>	UY1	V1	Key1
36	S1	3.17	.625	.714	1.25	3/4 Sq.
37	S1	3.17	.625	.714	1.25	3/4 Sq.
38	S2	3.17	0.625	0.714	1.25	3/16 Sq.

### Motor Frame

Gear Frame	143T-145T		
	XH	XL	XW
36	3.75	48.39	11.38
37	3.75	53.72	11.38
38	5.56	56.29	12.75

<sup>1</sup> Dimension "D" will never be exceeded, but may vary from values shown. When exact dimensions are required, shims up to .03" may be necessary.

<sup>2</sup> All rough casting dimensions may vary by .25" due to casting variations.

<sup>3</sup> Output shaft extension tolerances: +.0000"; -.0005" for shafts up to 1.5" diameter "U". Larger diameter "U", +.000"; -.001".

<sup>4</sup> Input shaft extension tolerances: +.0000"; -.0005" up to 1.5" diameter. Larger diameter "U1", +.000"; -.001".

## 3-Stage Output Shafted Flange Mount OtN33 - 35

OtN Series

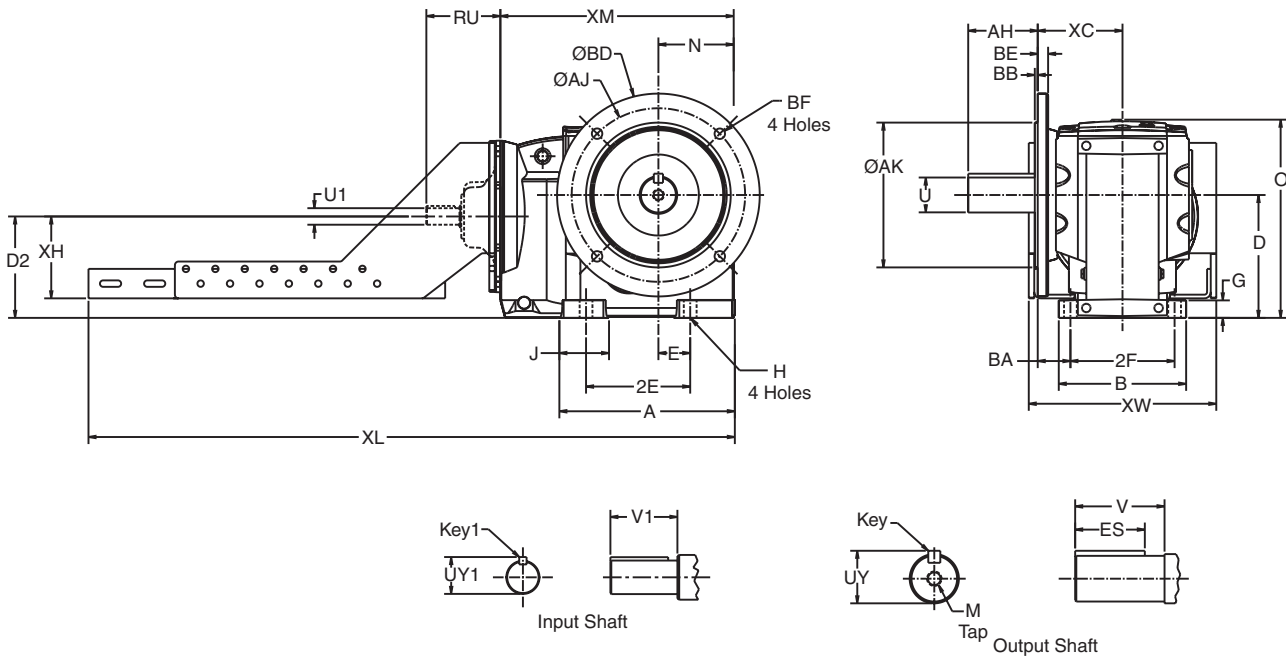

Gear Frame	Version	A	B	D <sup>1</sup>	D2	E	2E	2F	G	H	J	O	N	BA	XC	XM
33	S1,S2	8.50	6.61	5.51	5.24	1.18	4.72	5.51	.85	.55	2.86	9.69	3.54	2.24	4.84	11.97
34	S1,S2	10.13	7.87	7.09	5.90	1.57	5.91	6.50	1.07	.71	2.67	12.05	4.49	1.93	5.18	13.78
35	S2	11.92	8.66	8.35	6.89	2.17	7.09	7.09	1.18	.87	3.45	13.58	5.20	2.22	5.76	15.95

### Output Shaft

Gear Frame	Version	U <sup>3</sup>	UY	V	AH	Key	ES	M
33	S2	1.625	1.783	3.25	3.15	3/8 Sq.	2.78	5/8-11 X 1.38
	S1	1.500	1.657	3.18	2.28	3/8 Sq.	2.19	5/8-11 X 1.38
34	S2	2.000	2.210	3.94	3.94	1/2 Sq.	3.06	3/4-10 X 1.61
	S1	1.750	1.909	3.56	3.28	3/8 Sq.	3.56	3/4-10 X 1.61
35	S2	2.375	2.638	4.72	4.72	5/8 Sq.	3.81	3/4-10 X 1.61

### Output Flange

Gear Frame	Flange Code	AK	AJ	BB	BD	BE	BF
33	5	7.087	8.46	.16	9.84	.47	.55
	6	9.055	10.43	.16	11.81	.47	.55
34	5	9.055	10.43	.16	11.81	.59	.55
	6	9.842	11.80	.16	13.77	.59	.71
35	5	9.842	11.80	.20	13.77	.71	.71
	6	11.810	13.77	.20	15.75	.71	.71

### Input Shaft

Gear Frame	Version	RU	U1 <sup>4</sup>	UY1	V1	Key1
33	S1,S2	3.17	.625	.705	1.25	3/16 Sq.
34	S1,S2	4.75	1.125	1.236	2.25	1/4 Sq.
35	S2	5.03	1.125	1.236	2.25	1/4 Sq.

### Motor Frame

Gear Frame	143T-145T			182T-184T			213T-215T		
	XH	XL	XW	XH	XL	XW	XH	XL	XW
33	3.75	30.25	11.38	-	-	-	-	-	-
34	4.74	39.25	12.38	4.74	39.25	12.38	-	-	-
35	5.50	42.61	12.75	5.50	41.61	12.75	5.50	42.01	12.75

<sup>1</sup> Dimension "D" will never be exceeded, but may vary from values shown. When exact dimensions are required, shims up to .03" may be necessary.

<sup>2</sup> All rough casting dimensions may vary by .25" due to casting variations.

<sup>3</sup> Output shaft extension tolerances: +.0000"; -.0005" for shafts up to 1.5" diameter "U". Larger diameter "U", +.000"; -.001".

<sup>4</sup> Input shaft extension tolerances: +.0000"; -.0005" up to 1.5" diameter. Larger diameter "U1", +.000"; -.001".

## 3-Stage Output Shafted Flange Mount OtN36 - 38

OtN Series

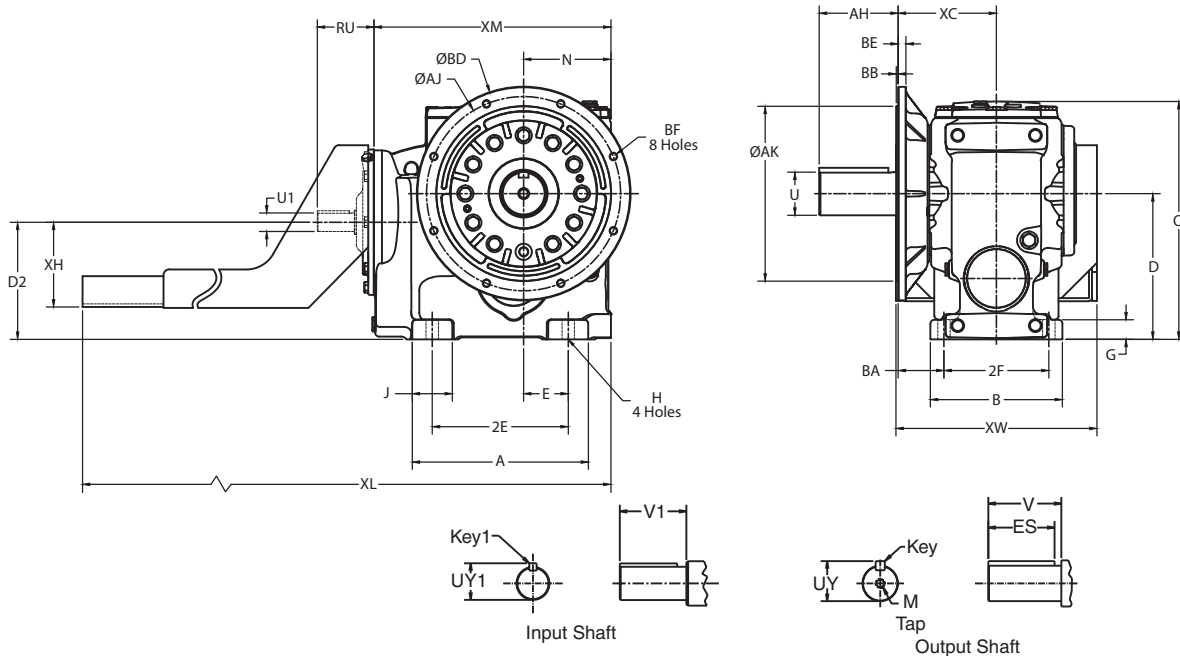

Gear Frame	Version	A	B	D <sup>1</sup>	D2	E	2E	2F	G	H	J	O	N	BA	XC	XM
36	S2	17.06	11.41	8.86	8.86	6.99	13.98	9.45	1.57	.87	3.87	16.26	8.74	4.45	9.17	30.10
37	S2	20.58	12.99	9.84	10.98	8.27	16.54	10.63	1.93	.94	4.78	18.29	10.04	4.45	9.76	35.43
38	S2	17.85	13.39	14.76	11.87	4.53	13.78	10.63	1.98	1.26	4.06	24.11	8.86	4.65	9.96	24.02

### Output Shaft

Gear Frame	Version	U <sup>3</sup>	UY	V	AH	KEY	ES	M
36	S2	2.875	3.20	7.68	5.51	3/4 Sq.	5.00	3/4-10 x 1.61
37	S2	3.625	4.01	8.88	6.69	7/8 Sq.	6.00	1-8 x 2.13
38	S2	4.375	4.809	8.99	9.97	1.00 Sq.	7.00	1-8 X 2.25

### Output Flange

Gear Frame	Flange Code	AJ	AK	BB	BD	BE	BF
36 & 37	5	13.78	15.75	.236	17.70	.79	.71
	6	17.72	19.68	.236	21.65	.63	.87
38	5	17.72	19.69	.200	21.65	.79	.69
	6	21.65	23.62	.236	25.98	.63	.87

### Input Shaft

Gear Frame	Version	RU	U1 <sup>4</sup>	UY1	V1	Key1
36	S2	7.56	1.875	2.101	3.75	1/2 Sq.
37	S2	7.56	1.875	2.101	3.75	1/2 Sq.
38	S2	7.56	1.875	2.101	3.75	1/2 Sq.

### Motor Frame

Gear Frame	182-184T			213-215T			254-256T			284T-286T			324T-326T		
	XH	XL	XW	XH	XL	XW	XH	XL	XW	XH	XL	XW	XH	XL	XW
36	6.63	55.06	15.00	6.63	55.06	15.00	6.63	55.06	15.00	8.50	59.06	19.06	8.50	59.06	19.06
37	6.63	60.40	15.00	6.63	60.40	15.00	6.63	60.40	15.00	8.50	64.40	19.06	8.50	64.40	19.06
38	-	-	-	-	-	-	8.50	59.93	19.06	8.50	58.93	19.06	9.50	60.93	21.31

<sup>1</sup> Dimension "D" will never be exceeded, but may vary from values shown. When exact dimensions are required, shims up to .03" may be necessary.

<sup>2</sup> All rough casting dimensions may vary by .25" due to casting variations.

<sup>3</sup> Output shaft extension tolerances: +.0000"; -.0005" for shafts up to 1.5" diameter "U". Larger diameter "U", +.000"; -.001".

<sup>4</sup> Input shaft extension tolerances: +.0000"; -.0005" up to 1.5" diameter. Larger diameter "U1", +.000"; -.001".



## Combined Output Shafted Flange Mount OtN36 - 38

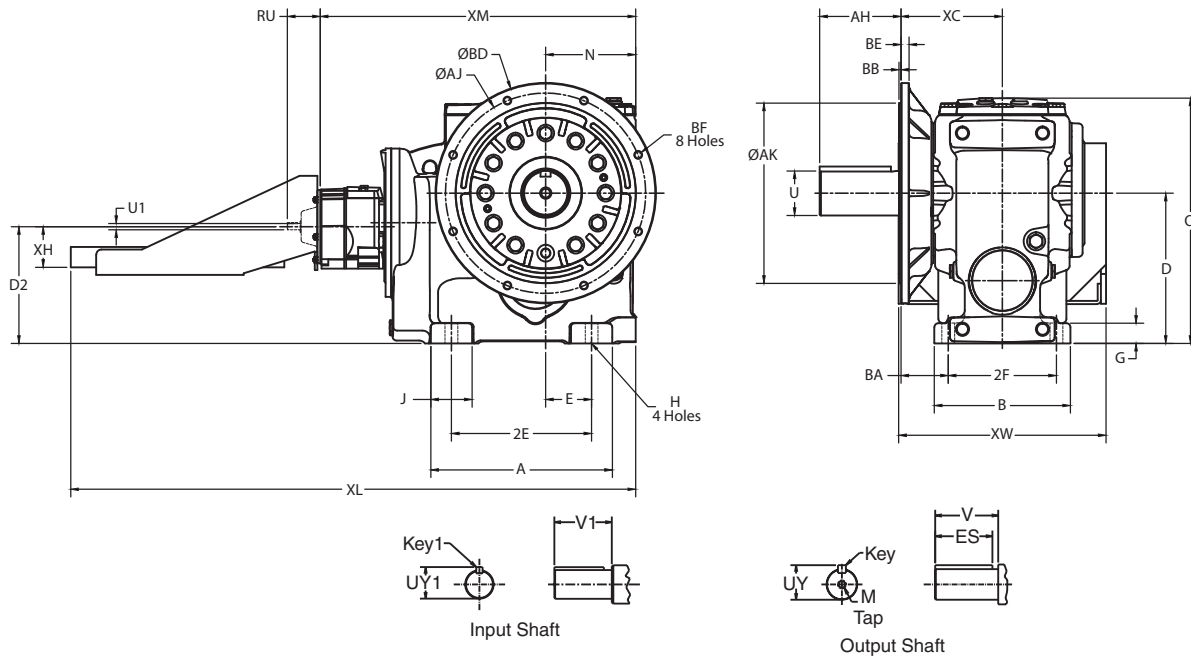

Gear Frame	Version	A	B	D <sup>1</sup>	D2	E	2E	2F	G	H	J	O	N	BA	XC	XM
36	S2	17.06	11.41	8.86	S2	8.46	13.98	9.45	1.57	.87	3.87	16.26	8.74	4.45	9.17	30.10
37	S2	20.58	12.99	9.84	S2	10.57	16.54	10.63	1.93	.94	4.78	18.29	10.04	4.45	9.76	35.43
38	S2	17.85	13.39	14.76	11.48	4.53	13.78	10.63	1.98	1.26	4.06	24.11	8.86	4.65	9.96	31.00

### Output Shaft

Gear Frame	Version	U <sup>3</sup>	UY	V	AH	KEY	ES	M
36	S2	2.875	3.20	7.68	5.51	3/4 Sq.	5.00	3/4-10 x 1.61
37	S2	3.625	4.01	8.88	6.69	7/8 Sq.	6.00	1-8 x 2.13
38	S2	4.375	4.809	8.99	9.97	1.00 Sq.	7.00	1-8 x 2.25

### Output Flange

Gear Frame	Flange Code	AJ	AK	BB	BD	BE	BF
36 & 37	5	13.78	15.75	.236	17.70	.79	.71
	6	17.72	19.68	.236	21.65	.63	.87
38	5	17.72	19.69	.200	21.65	.79	.69
	6	21.65	23.62	.236	25.98	.63	.87

### Input Shaft

Gear Frame	Version	RU	U1 <sup>4</sup>	UY1	V1	Key1
36	S2	3.17	.625	.714	1.25	3/16 Sq.
37	S2	3.17	.625	.714	1.25	3/16 Sq.
38	S2	3.17	0.625	0.714	1.25	3/16 Sq.

### Motor Frame

Gear Frame	143T-145T		
	XH	XL	XW
36	3.75	48.39	11.38
37	3.75	53.72	11.38
38	5.56	56.29	12.75

<sup>1</sup> Dimension "D" will never be exceeded, but may vary from values shown. When exact dimensions are required, shims up to .03" may be necessary.  
<sup>2</sup> All rough casting dimensions may vary by .25" due to casting variations.

<sup>3</sup> Output shaft extension tolerances: +.0000"; -.0005" for shafts up to 1.5" diameter "U". Larger diameter "U", +.000"; -.001".

<sup>4</sup> Input shaft extension tolerances: +.0000"; -.0005" up to 1.5" diameter. Larger diameter "U1", +.000"; -.001".

## 3-Stage Finished Bore Hollow Shaft OtN33 - 35

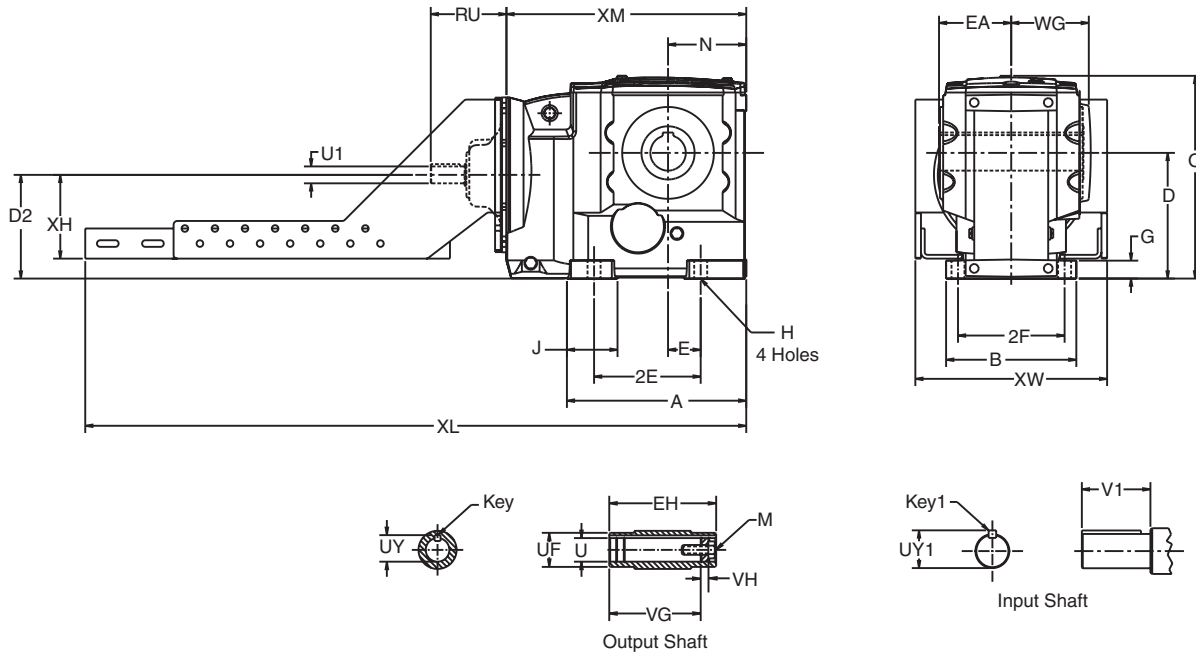

OtN Series

Gear Frame	Version	A	B	D'	D2	E	2E	2F	G	H	J	O	N	WG	XM
33	S2	8.50	6.61	5.51	5.24	1.18	4.72	5.51	.85	.55	2.86	9.69	3.54	3.73	11.97
34	S2	10.13	7.87	7.09	5.90	1.57	5.91	6.50	1.07	.71	2.67	12.05	4.49	4.66	13.78
35	S2	11.92	8.66	8.35	6.89	2.17	7.09	7.09	1.18	.87	3.45	13.58	5.20	5.15	15.95

### Output Shaft

Gear Frame	Version	EH	U <sup>4,7</sup>	UY	EA	UF	VG	VH	Key <sup>5</sup>	M
33	S2	6.94	1.500	1.674	3.47	2.16	5.96	.55	3/8 X 3/8 X 2 1/4	5/8-11 X 1.75
34	S2	8.97	2.000	2.210	4.49	2.56	7.44	.79	1/2 X 7/16 X 2 5/8	5/8-11 X 1.75
35	S2	9.66	2.375	2.656	4.83	3.54	8.15	.94	5/8 X 5/8 X 3 5/8	3/4-10 X 2.00

### Input Shaft

Gear Frame	Version	RU	U1 <sup>6</sup>	UY1	V1	Key1
33	S2	3.17	.625	.705	1.25	3/16 Sq.
34	S2	4.75	1.125	1.236	2.25	1/4 Sq.
35	S2	5.03	1.125	1.236	2.25	1/4 Sq.

### Motor Frame

Gear Frame	143T-145T			182T-184T			213T-215T		
	XH	XL	XW	XH	XL	XW	XH	XL	XW
33	3.75	30.25	11.38	-	-	-	-	-	-
34	4.74	39.25	12.38	4.74	39.25	12.38	-	-	-
35	5.50	42.61	12.75	5.50	41.61	12.75	5.50	42.01	12.75

<sup>1</sup> Dimension "D" will never be exceeded, but may vary from values shown. When exact dimensions are required, shims up to .03" may be necessary.

<sup>2</sup> All rough casting dimensions may vary by .25" due to casting variations.

<sup>3</sup> Driven shaft entry can be from either side of the gear reducer housing by reversing positioning of the snap rings and washer illustrated.

<sup>4</sup> Output finished bore tolerance: +.0020", -.0000 for all diameters.

<sup>5</sup> Output key supplied only on frame 34 "S2" version.

<sup>6</sup> Input shaft extension tolerances: +.0000"; -.0005" up to 1.5" diameter. Larger diameter "U1", +.000"; -.001".

<sup>7</sup> Refer to Tapered Bushed designs if driven shaft varies from "U" dimensions offered above.

<sup>8</sup> For details of the torque arm kit, refer to page B-198.

**3-Stage Finished Bore Hollow Shaft**  
**OtN36 - 38**

OtN Series

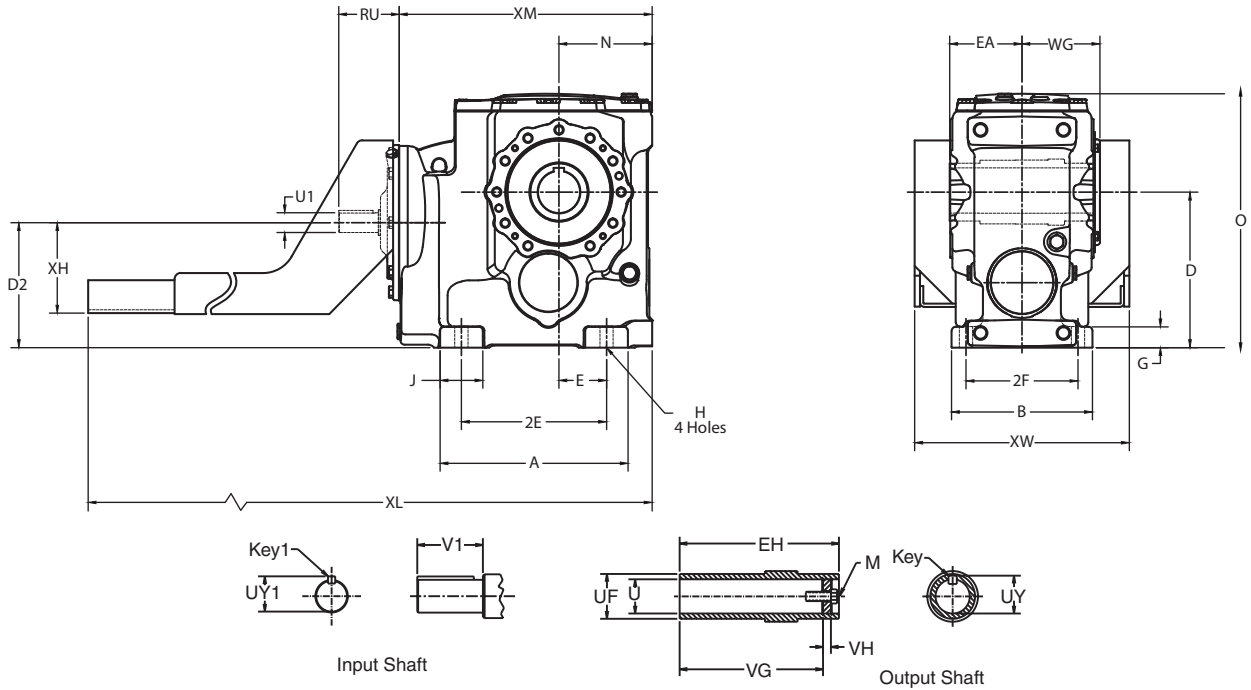

Gear Frame	Version	A	B	D <sup>1</sup>	D2	E	2E	2F	G	H	J	O	N	WG	XM
36	S2	17.06	11.41	8.86	8.86	6.99	13.98	9.45	1.57	.87	3.87	16.26	8.74	6.78	23.11
37	S2	20.58	12.99	9.84	10.98	8.27	16.54	10.63	1.93	.94	4.78	18.29	10.04	7.44	28.44
38	S2	17.85	13.39	14.76	11.87	4.53	13.78	10.63	1.98	1.26	4.06	24.11	8.86	7.40	24.02

**Output Shaft**

Gear Frame	Version	EA	EH	U <sup>4</sup>	UF	UY	VG	VH	Key <sup>7</sup>	M
36	S2	6.22	12.44	2.750	3.93	3.037	10.89	1.23	5/8 x 5/8 x 5 1/2	3/4-10 x 2.00
37	S2	6.22	13.59	3.625	4.72	4.019	11.90	1.23	7/8 x 7/8 x 5 1/2	3/4-10 x 2.00
38	S2	6.81	13.74	4.000	5.50	4.316	11.86	.92	1 x 1 x 6 1/2	1-8 x 2.25

**Input Shaft**

Gear Frame	Version	RU	U1 <sup>5</sup>	UY1	V1	Key1
36	S2	7.56	1.875	2.101	3.75	1/2 Sq.
37	S2	7.56	1.875	2.101	3.75	1/2 Sq.
38	S2	7.56	1.875	2.101	3.75	1/2 Sq.

**Motor Frame**

Gear Frame	182-184T			213-215T			254-256T			284T-286T			324T-326T		
	XH	XL	XW	XH	XL	XW	XH	XL	XW	XH	XL	XW	XH	XL	XW
36	6.63	55.06	15.00	6.63	55.06	15.00	6.63	55.06	15.00	8.50	59.06	19.06	8.50	59.06	19.06
37	6.63	60.4	15.00	6.63	60.4	15.00	6.63	60.4	15.00	8.50	64.4	19.06	8.50	64.4	19.06
38	-	-	-	-	-	-	8.50	59.93	19.06	8.50	58.93	19.06	9.50	60.93	21.31

<sup>1</sup> Dimension "D" will never be exceeded, but may vary from values shown. When exact dimensions are required, shims up to .03" may be necessary.

<sup>2</sup> All rough casting dimensions may vary by .25" due to casting variations.

<sup>3</sup> Driven shaft entry can be from either side of the gear reducer housing by reversing positioning of the snap rings and washer illustrated.

<sup>4</sup> Output finished bore tolerance: +.0020", -.0000 for all diameters.

<sup>5</sup> Input shaft extension tolerances: +.0000"; -.0005" up to 1.5" diameter. Larger diameter "U1", +.000"; -.001".

<sup>6</sup> For details of the torque arm kit, refer to page B-129.

<sup>7</sup> Key not supplied with reducer.

Combined Finished Bore Hollow Shaft  
OtN36 - 38

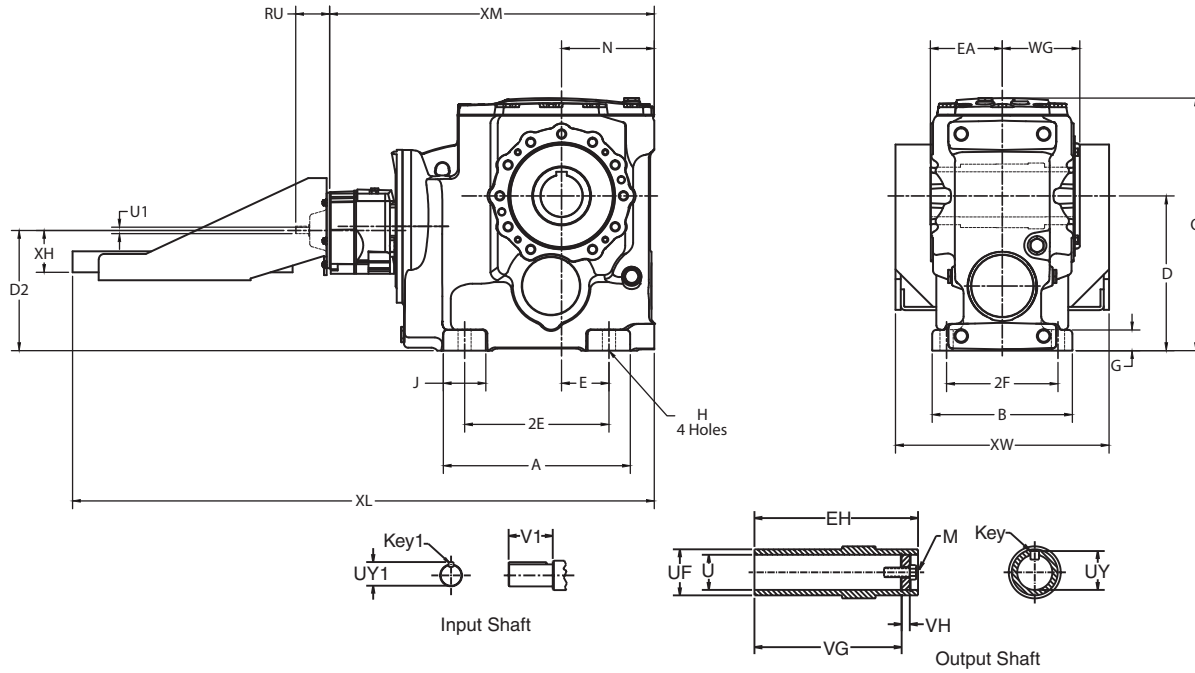

OtN Series

Gear Frame	Version	A	B	D <sup>1</sup>	D2	E	2E	2F	G	H	J	O	N	WG	XM
36	S2	17.06	11.41	8.86	8.46	6.99	13.98	9.45	1.57	.87	3.87	16.26	8.74	6.78	30.10
37	S2	20.58	12.99	9.84	10.57	8.27	16.54	10.63	1.93	.94	4.78	18.29	10.04	7.44	35.43
38	S2	17.85	13.39	14.76	11.48	4.53	13.78	10.63	1.98	1.26	4.06	24.11	8.86	7.40	31.00

Output Shaft

Gear Frame	Version	EA	EH	U <sup>4</sup>	UF	UY	VG	VH	Key <sup>7</sup>	M
36	S2	6.22	12.44	2.750	3.93	3.037	10.89	1.23	5/8 x 5/8 x 5 1/2	3/4-10 x 2.00
37	S2	6.80	13.59	3.625	4.72	4.019	11.90	1.23	7/8 x 7/8 x 5 1/2	3/4-10 x 2.00
38	S2	6.81	13.74	4.000	5.50	4.316	11.86	.92	1 x 1 x 6 1/2	1-8 x 2.25

Input Shaft

Gear Frame	Version	RU	U1 <sup>5</sup>	UY1	V1	Key1
36	S2	3.17	.625	.714	1.25	3/16 Sq.
37	S2	3.17	.625	.714	1.25	3/16 Sq.
38	S2	3.17	.625	.714	1.25	3/16 Sq.

Motor Frame

Gear Frame	143T-145T		
	XH	XL	XW
36	3.75	48.39	11.38
37	3.75	53.72	11.38
38	5.56	56.29	12.75

<sup>1</sup> Dimension "D" will never be exceeded, but may vary from values shown. When exact dimensions are required, shims up to .03" may be necessary.  
<sup>2</sup> All rough casting dimensions may vary by .25" due to casting variations.  
<sup>3</sup> Driven shaft entry can be from either side of the gear reducer housing by reversing positioning of the snap rings and washer illustrated.

<sup>4</sup> Output finished bore tolerance: +.0020", -.0000 for all diameters.  
<sup>5</sup> Input shaft extension tolerances: +.0000"; -.0005" up to 1.5" diameter. Larger diameter "U1", +.000"; -.001".  
<sup>6</sup> For details of the torque arm kit, refer to page B-129.  
<sup>7</sup> Key not supplied with reducer.

**3-Stage Finished Bore Hollow Shaft Face Mount**  
**OtN33 - 35**

OtN Series

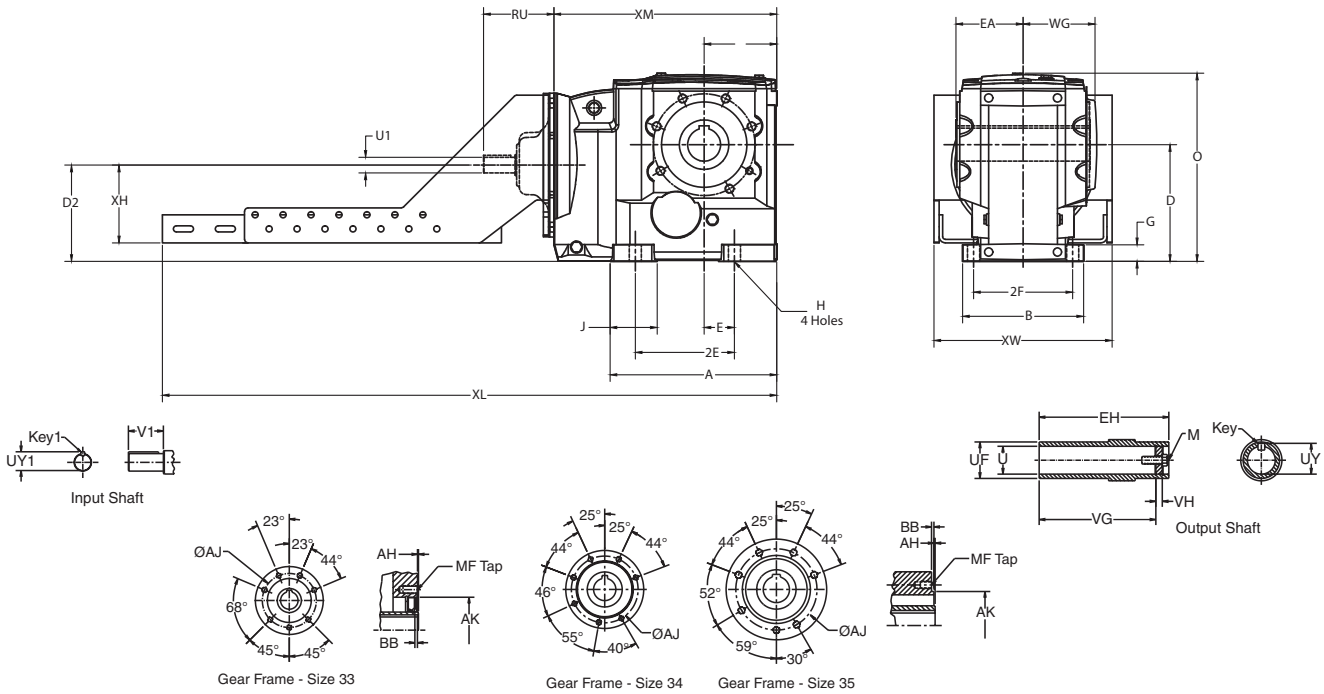

Gear Frame	Version	A	B	D <sup>1</sup>	D2	E	2E	2F	G	H	J	O	N	WG	XM
33	S2	8.50	6.61	5.51	5.24	1.18	4.72	5.51	.85	.55	2.86	9.69	3.54	3.63	11.97
34	S2	10.13	7.87	7.09	5.90	1.57	5.91	6.50	1.07	.71	2.67	12.05	4.49	4.66	13.78
35	S2	11.92	8.66	8.35	6.89	2.17	7.09	7.09	1.18	.87	3.45	13.58	5.20	5.15	15.95

**Output Shaft**

Gear Frame	Version	EA	EH	U <sup>5</sup>	UF	UY	VG	VH	Key <sup>4</sup>	M
33	S2	3.47	6.94	1.500	2.16	1.674	5.96	.55	3/8 X 3/8 X 2 1/4	5/8-11 X 1.75
34	S2	4.49	8.97	2.000	2.56	2.210	7.44	.79	1/2 X 7/16 X 2 5/8	5/8-11 X 1.75
35	S2	4.83	9.66	2.375	3.54	2.656	8.15	.94	5/8 X 5/8 X 3 5/8	3/4-10 X 2.00

**Output Face**

Gear Frame	Version	AH	AJ	AK	BB	MF
33	S2	.12	4.84	3.94	.16	M12-1.75 X 22
34	S2	.14	5.98	5.12	.28	M12-1.75 X 22
35	S2	.13	7.48	6.10	.28	M16-2.00 X 27

**Input Shaft**

Gear Frame	Version	RU	U1 <sup>6</sup>	UY1	V1	KEY <sup>1</sup>
33	S2	3.17	.625	.705	1.25	3/16 Sq.
34	S2	4.75	1.125	1.236	2.25	1/4 Sq.
35	S2	5.03	1.125	1.236	2.25	1/4 Sq.

**Motor Frame**

Gear Frame	143T-145T			182T-184T			213T-215T		
	XH	XL	XW	XH	XL	XW	XH	XL	XW
33	3.75	30.25	11.38	-	-	-	-	-	-
34	4.74	39.25	12.38	4.74	39.25	12.38	-	-	-
35	5.50	42.61	12.75	5.50	41.61	12.75	5.50	42.01	12.75

<sup>1</sup> Dimension "D" will never be exceeded, but may vary from values shown. When exact dimensions are required, shims up to .03" may be necessary.  
<sup>2</sup> All rough casting dimensions may vary by .25" due to casting variations.  
<sup>3</sup> Driven shaft entry can be from either side of the gear reducer housing by reversing positioning of the snap rings and washer illustrated.

<sup>4</sup> Output key supplied only on frame 34 "S2" version.  
<sup>5</sup> Output finished bore tolerance: +.0020", -.0000 for all diameters.  
<sup>6</sup> Input shaft extension tolerances: +.0000"; -.0005" up to 1.5" diameter. Larger diameter "U1", +.000"; -.001".

## 3-Stage Finished Bore Hollow Shaft Face Mount OtN36 - 38

# OtN Series

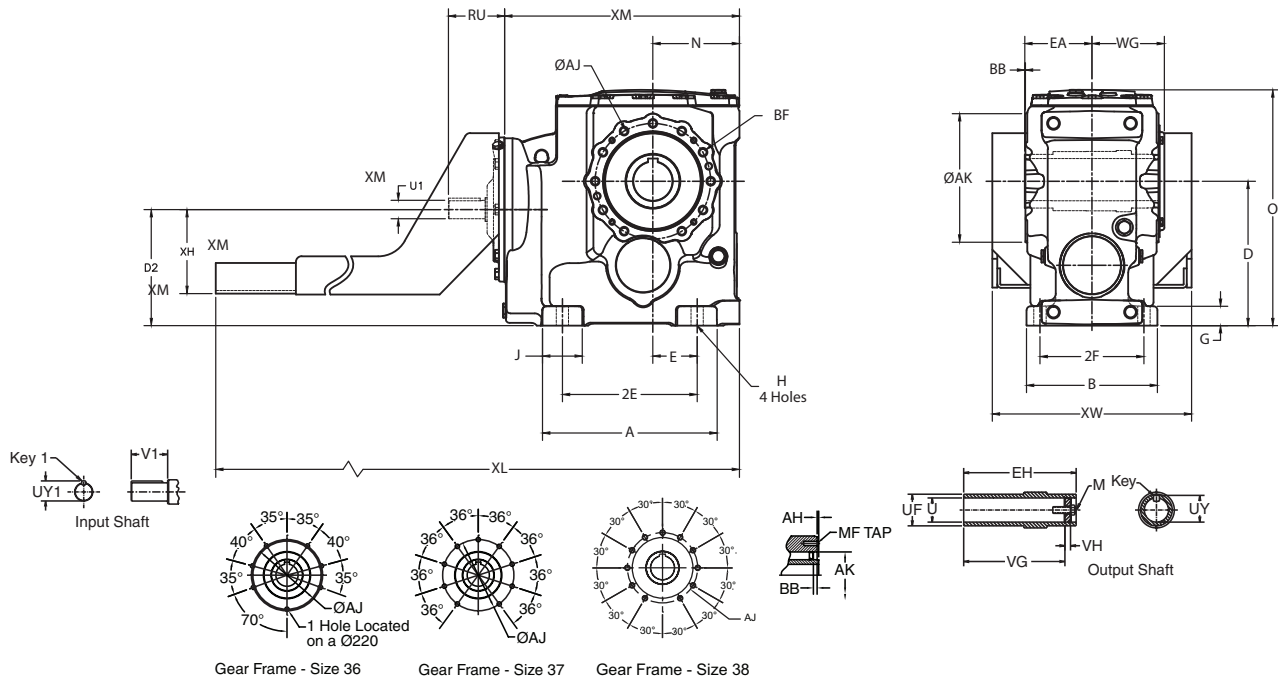

Gear Frame	Version	A	B	D <sup>1</sup>	D <sub>2</sub>	E	2E	2F	G	H	J	O	N	WG	XM
36	S2	17.06	11.41	8.86	8.86	6.99	13.98	9.45	1.57	.87	3.87	16.26	8.74	6.78	23.11
37	S2	20.58	12.99	9.84	10.98	8.27	16.54	10.63	1.93	.94	4.78	18.29	10.04	7.44	28.44
38	S2	17.85	13.39	14.76	11.87	4.53	13.78	10.63	1.98	1.26	4.06	24.11	8.86	7.40	24.02

### Output Shaft

Gear Frame	Version	EA	EH	U <sup>4</sup>	UF	UY	VG	VH	Key <sup>6</sup>	M
36	S2	6.22	12.44	2.750	3.93	3.037	10.89	1.23	5/8 x 5/8 x 5 1/2	3/4-10 x 2.00
37	S2	6.80	13.59	3.625	4.72	4.019	11.90	1.23	7/8 x 7/8 x 5 1/2	3/4-10 x 2.00
38	S2	6.81	13.74	4.000	5.50	4.316	11.86	.92	1 x 1 x 6 1/2	1-8 x 2.25

### Output Face

Gear Frame	Version	AH	AJ	AK	BB	BF
36	S2	-	9.06	5.91	.28	M16-2.0 x 27
37	S2	-	9.06	7.09	.28	M20-2.5 x 35
38	S2	.10	11.81	9.84	.20	M20-2.00 x 35

### Input Shaft

Gear Frame	Version	RU	U1 <sup>5</sup>	UY1	V1	Key1
36	S2	7.56	1.875	2.101	3.75	1/2 Sq.
37	S2	7.56	1.875	2.101	3.75	1/2 Sq.
38	S2	7.56	1.875	2.101	3.75	1/2 Sq.

### Motor Frame

Gear Frame	182-184T			213-215T			254-256T			284T-286T			324T-326T		
	XH	XL	XW	XH	XL	XW	XH	XL	XW	XH	XL	XW	XH	XL	XW
36	6.63	55.06	15.00	6.63	55.06	15.00	6.63	55.06	15.00	8.50	59.06	19.06	8.50	59.06	19.06
37	6.63	60.4	15.00	6.63	60.4	15.00	6.63	60.4	15.00	8.50	64.4	19.06	8.50	64.4	19.06
38	-	-	-	-	-	-	8.50	59.93	19.06	8.50	58.93	19.06	9.50	60.93	21.31

<sup>1</sup> Dimension "D" will never be exceeded, but may vary from values shown. When exact dimensions are required, shims up to .03" may be necessary.  
<sup>2</sup> All rough casting dimensions may vary by .25" due to casting variations.  
<sup>3</sup> Driven shaft entry can be from either side of the gear reducer housing by reversing positioning of the snap rings and washer illustrated.

<sup>4</sup> Output finished bore tolerance: +.0020", -.0000 for all diameters.  
<sup>5</sup> Input shaft extension tolerances: +.0000"; -.0005" up to 1.5" diameter. Larger diameter "U1", +.000"; -.001".  
<sup>6</sup> Key not supplied with reducer.

## Combined Finished Bore Hollow Shaft Face Mount OtN36 - 38

OtN Series

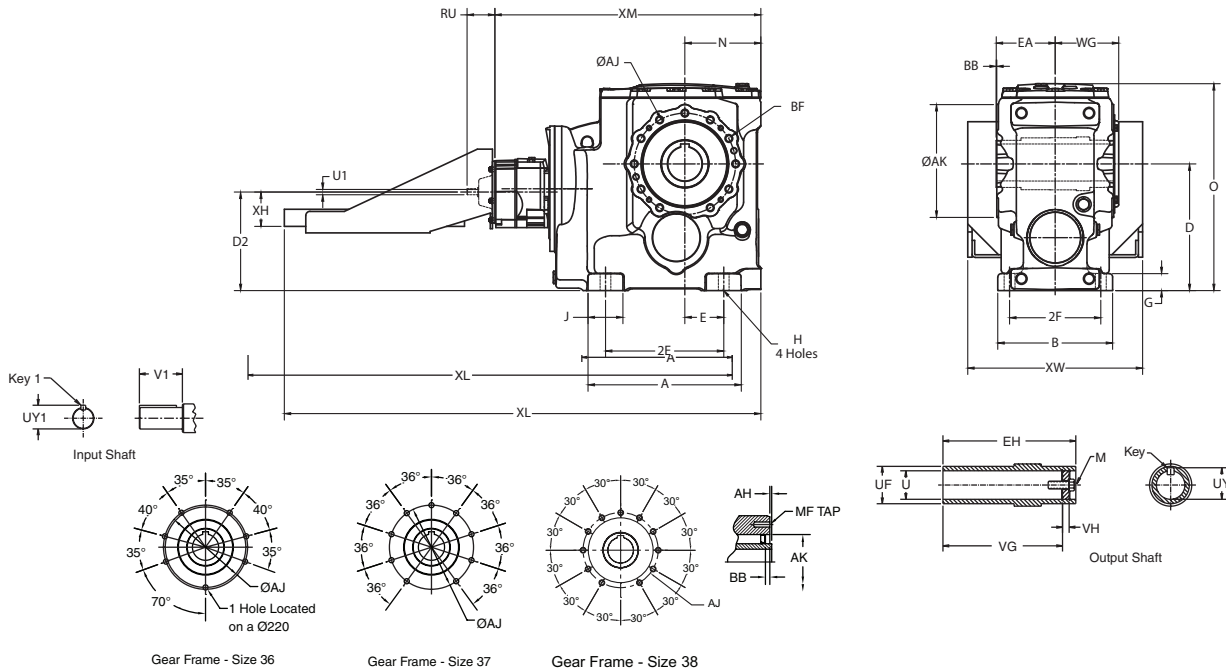

Gear Frame	Version	A	B	D <sup>1</sup>	D2	E	2E	2F	G	H	J	O	N	WG	XM
36	S2	17.06	11.41	8.86	8.46	6.99	13.98	9.45	1.57	.87	3.87	16.26	8.74	6.78	30.10
37	S2	20.58	12.99	9.84	10.57	8.27	16.54	10.63	1.93	.94	4.78	18.29	10.04	7.44	35.43
38	S2	17.85	13.39	14.76	11.48	4.53	13.78	10.63	1.98	1.26	4.06	24.11	8.86	7.40	31.00

### Output Shaft

Gear Frame	Version	EA	EH	U <sup>4</sup>	UF	UY	VG	VH	Key <sup>6</sup>	M
36	S2	6.22	12.44	2.750	3.93	3.037	10.89	1.23	5/8 x 5/8 x 5 1/2	3/4-10 x 2.00
37	S2	6.80	13.59	3.625	4.72	4.019	11.90	1.23	7/8 x 7/8 x 5 1/2	3/4-10 x 2.00
38	S2	6.81	13.74	4.000	5.50	4.316	11.86	.92	1 X 1 x 6 1/2	1-8 x 2.25

### Output Face

Gear Frame	Version	AH	AJ	AK	BB	BF
36	S2	-	9.06	5.91	.28	M16-2.0 x 27
37	S2	-	9.06	7.09	.28	M20-2.5 x 35
38	S2	.10	11.81	9.84	.20	M20-2.0 X 35

### Input Shaft

Gear Frame	Version	RU	U1 <sup>5</sup>	UY1	V1	Key1
36	S2	3.17	.625	.714	1.25	3/16 Sq.
37	S2	3.17	.625	.714	1.25	3/16 Sq.
38	S2	3.17	.63	.71	1.25	3/16 Sq.

### Motor Frame

Gear Frame	143T-145T		
	XH	XL	XW
36	3.75	48.39	11.38
37	3.75	53.72	11.38
38	5.56	56.29	12.75

<sup>1</sup> Dimension "D" will never be exceeded, but may vary from values shown. When exact dimensions are required, shims up to .03" may be necessary.  
<sup>2</sup> All rough casting dimensions may vary by .25" due to casting variations.  
<sup>3</sup> Driven shaft entry can be from either side of the gear reducer housing by reversing positioning of the snap rings and washer illustrated.

<sup>4</sup> Output finished bore tolerance: +.0020", -.0000 for all diameters.  
<sup>5</sup> Input shaft extension tolerances: +.0000"; -.0005" up to 1.5" diameter. Larger diameter "U1", +.000"; -.001".  
<sup>6</sup> Key not supplied with reducer.



## 3-Stage Finished Bore Hollow Shaft Flange Mount OtN33 - 35

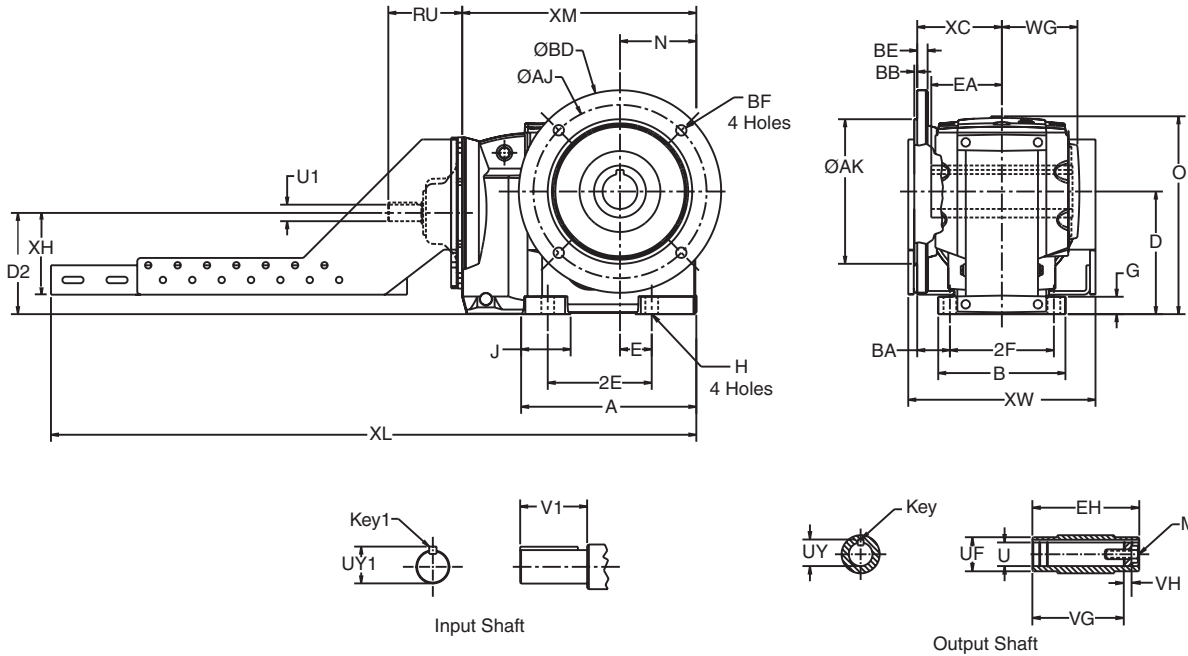

OtN Series

Gear Frame	Version	A	B	D <sup>1</sup>	D2	E	2E	2F	G	H	J	O	N	BA	WG	XC	XM
33	S2	8.50	6.61	5.51	5.24	1.18	4.72	5.51	.85	.55	2.86	9.69	3.54	2.08	3.73	4.84	11.97
34	S2	10.13	7.87	7.09	5.90	1.57	5.91	6.50	1.07	.71	2.67	12.05	4.49	1.93	4.66	5.18	13.78
35	S2	11.92	8.66	8.35	6.89	2.17	7.09	7.09	1.18	.87	3.45	13.58	5.20	2.22	5.15	5.77	15.95

### Output Shaft

Gear Frame	Version	EA	EH	U <sup>5</sup>	UF	UY	VG	VH	Key <sup>4</sup>	M
33	S2	3.47	6.94	1.500	2.16	1.674	5.96	.55	3/8 X 3/8 X 2 1/4	5/8-11 X 1.75
34	S2	4.49	8.97	2.000	2.56	2.210	7.44	.79	1/2 X 7/16 X 2 5/8	5/8-11 X 1.75
35	S2	4.83	9.66	2.375	3.54	2.656	8.15	.94	5/8 X 5/8 X 3 5/8	3/4-10 X 2.00

### Output Flange

Gear Frame	Flange Code	AK	AJ	BB	BD	BE	BF
33	5	7.087	8.46	.16	9.84	.47	.55
	6	9.055	10.43	.16	11.81	.47	.55
34	5	9.055	10.43	.16	11.81	.59	.55
	6	9.842	11.80	.16	13.77	.59	.71
35	5	9.842	11.80	.20	13.77	.71	.71
	6	11.810	13.77	.20	15.75	.71	.71

### Input Shaft

Gear Frame	Version	RU	U1 <sup>6</sup>	UY1	V1	Key1
33	S2	3.17	.625	.705	1.25	3/16 Sq.
34	S2	4.75	1.125	1.236	2.25	1/4 Sq.
35	S2	5.03	1.125	1.236	2.25	1/4 Sq.

### Motor Frame

Gear Frame	143T-145T			182T-184T			213T-215T		
	XH	XL	XW	XH	XL	XW	XH	XL	XW
33	3.75	30.25	11.38	-	-	-	-	-	-
34	4.74	39.25	12.38	4.74	39.25	12.38	-	-	-
35	5.50	42.61	12.75	5.50	41.61	12.75	5.50	42.01	12.75

<sup>1</sup> Dimension "D" will never be exceeded, but may vary from values shown. When exact dimensions are required, shims up to .03" may be necessary.  
<sup>2</sup> All rough casting dimensions may vary by .25" due to casting variations.  
<sup>3</sup> Driven shaft entry can be from either side of the gear reducer housing by reversing positioning of the snap rings and washer illustrated.

<sup>4</sup> Output key supplied only on frame 34 "S2" version.  
<sup>5</sup> Output finished bore tolerance: +.0020", -.0000 for all diameters.  
<sup>6</sup> Input shaft extension tolerances: +.0000"; -.0005" up to 1.5" diameter. Larger diameter "U1", +.000"; -.001".

## 3-Stage Finished Bore Hollow Shaft Flange Mount OtN36 - 38

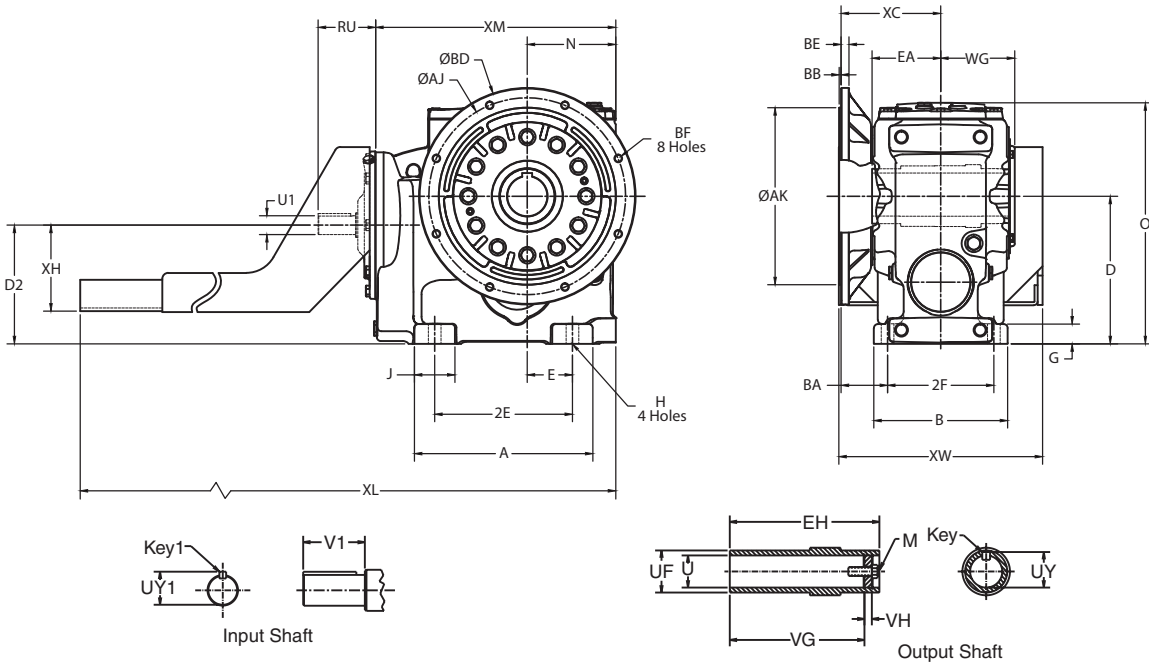

OtN Series

Gear Frame	Version	A	B	D <sup>1</sup>	D2	E	2E	2F	G	H	J	O	N	BA	WG	XC	XM
36	S2	17.06	11.41	8.86	8.86	6.99	13.98	9.45	1.57	.87	3.87	16.26	8.74	4.45	6.78	9.17	23.11
37	S2	20.58	12.99	9.84	10.98	8.27	16.54	10.63	1.93	.94	4.78	18.29	10.04	4.45	7.44	9.76	28.44
38	S2	17.85	13.39	14.76	11.87	4.53	13.78	10.63	1.98	1.26	4.06	24.11	8.86	4.65	7.40	9.96	24.02

### Output Shaft

Gear Frame	Version	EA	EH	U <sup>4</sup>	UF	UY	VG	VH	Key <sup>6</sup>	M
36	S2	6.22	12.44	2.750	3.93	3.037	10.89	1.23	5/8 x 5/8 x 5 1/2	3/4-10 x 2.00
37	S2	6.80	13.59	3.625	4.72	4.019	11.90	1.23	7/8 x 7/8 x 5 1/2	3/4-10 x 2.00
38	S2	6.81	13.74	4.000	5.50	4.316	11.86	.92	1 x 1 x 6 1/2	1-8 x 2.25

### Output Flange

Gear Frame	Flange Code	AJ	AK	BB	BD	BE	BF
36 & 37	5	15.75	13.780	.236	17.70	.79	.71
	6	19.68	17.72	.236	21.65	.63	.87
38	5	19.69	17.72	.20	21.65	.79	.69

### Input Shaft

Gear Frame	Version	RU	U1 <sup>5</sup>	UY1	V1	Key1
36	S2	7.56	1.875	2.101	3.75	1/2 Sq.
37	S2	7.56	1.875	2.101	3.75	1/2 Sq.
38	S2	7.56	1.875	2.101	3.75	1/2 Sq.

### Motor Frame

Gear Frame	182-184T			213-215T			254-256T			284T-286T			324T-326T		
	XH	XL	XW	XH	XL	XW	XH	XL	XW	XH	XL	XW	XH	XL	XW
36	6.63	55.06	15.00	6.63	55.06	15.00	6.63	55.06	15.00	8.50	59.06	19.06	8.50	59.06	19.06
37	6.63	60.4	15.00	6.63	60.4	15.00	6.63	60.4	15.00	8.50	64.4	19.06	8.50	64.4	19.06
38	-	-	-	-	-	-	8.50	59.93	19.06	8.50	58.93	19.06	9.50	60.93	21.31

<sup>1</sup> Dimension "D" will never be exceeded, but may vary from values shown. When exact dimensions are required, shims up to .03" may be necessary.

<sup>2</sup> All rough casting dimensions may vary by .25" due to casting variations.

<sup>3</sup> Driven shaft entry can be from either side of the gear reducer housing by reversing positioning of the snap rings and washer illustrated.

<sup>4</sup> Output finished bore tolerance: +.0020", -.0000 for all diameters.

<sup>5</sup> Input shaft extension tolerances: +.0000"; -.0005" up to 1.5" diameter. Larger diameter "U1", +.000"; -.001".

<sup>6</sup> Key not supplied with reducer.

## Combined Finished Bore Hollow Shaft Flange Mount OtN36 - 38

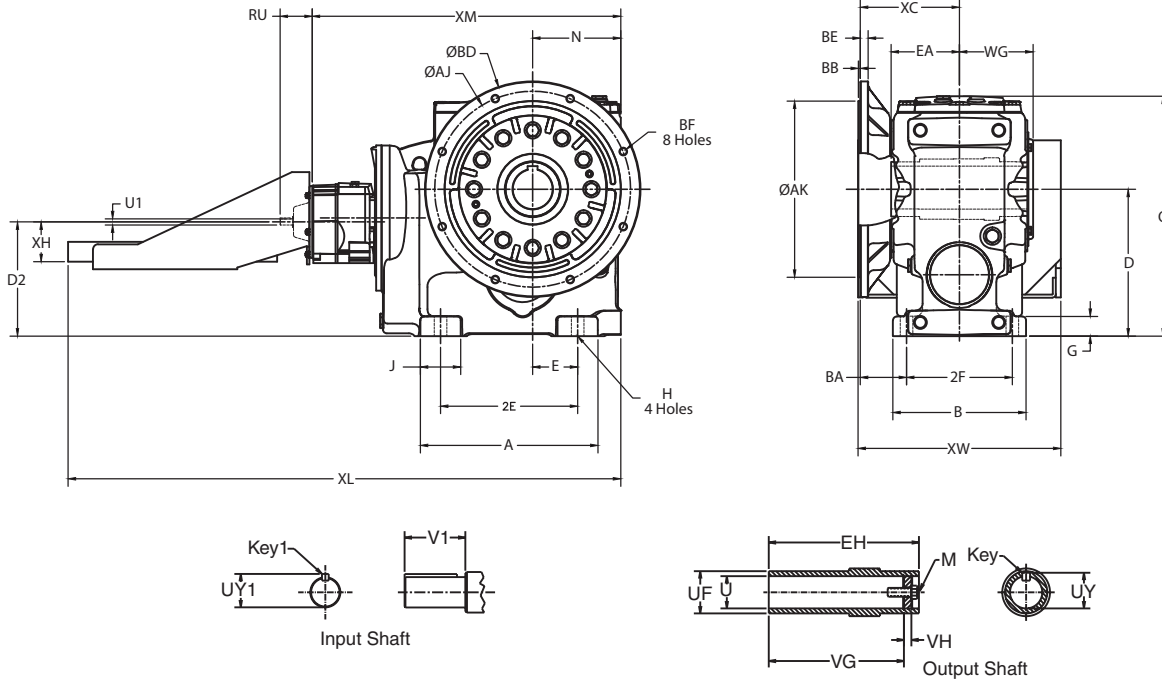

OtN Series

Gear Frame	Version	A	B	D <sup>1</sup>	D2	E	2E	2F	G	H	J	O	N	BA	WG	XC	XM
36	S2	17.06	11.41	8.86	8.46	6.99	13.98	9.45	1.57	.87	3.87	16.26	8.74	4.45	6.78	9.17	30.10
37	S2	20.58	12.99	9.84	10.57	8.27	16.54	10.63	1.93	.94	4.78	18.29	10.04	4.45	7.44	9.76	35.43
38	S2	17.85	13.39	14.76	11.48	4.53	13.78	10.63	1.98	1.26	4.06	24.11	8.86	4.65	7.40	9.96	31.00

### Output Shaft

Gear Frame	Version	EA	EH	U <sup>4</sup>	UF	UY	VG	VH	Key <sup>6</sup>	M
36	S2	6.22	12.44	2.750	3.93	3.037	10.89	1.23	5/8 x 5/8 x 5 1/2	3/4-10 x 2.00
37	S2	6.80	13.59	3.625	4.72	4.019	11.90	1.23	7/8 x 7/8 x 5 1/2	3/4-10 x 2.00
38	S2	6.81	13.74	4.000	5.50	4.316	11.86	.92	1 x 1 x 6 1/2	1-8 x 2.25

### Output Flange

Gear Frame	Flange Code	AJ	AK	BB	BD	BE	BF
36 & 37	5	15.75	13.780	.236	17.70	.79	.71
	6	19.68	17.72	.236	21.65	.63	.87
38	5	19.69	17.72	.20	21.65	.79	.69

### Input Shaft

Gear Frame	Version	RU	U1 <sup>5</sup>	UY1	V1	Key1
36	S2	3.17	.625	.714	1.25	3/16 Sq.
37	S2	3.17	.625	.714	1.25	3/16 Sq.
38	S2	3.17	.63	.71	1.25	3/16 Sq.

### Motor Frame

Gear Frame	143T-145T		
	XH	XL	XW
36	3.75	48.39	11.38
37	3.75	53.72	11.38
38	5.56	56.29	12.75

<sup>1</sup> Dimension "D" will never be exceeded, but may vary from values shown. When exact dimensions are required, shims up to .03" may be necessary.

<sup>2</sup> All rough casting dimensions may vary by .25" due to casting variations.

<sup>3</sup> Driven shaft entry can be from either side of the gear reducer housing by reversing positioning of the snap rings and washer illustrated.

<sup>4</sup> Output finished bore tolerance: +.0020", -.0000 for all diameters.

<sup>5</sup> Input shaft extension tolerances: +.0000"; -.0005" up to 1.5" diameter. Larger diameter "U1", +.000"; -.001".

<sup>6</sup> Key not supplied with reducer.

## 3-Stage Taper Bushed Shaft Mount OtN33 - 35

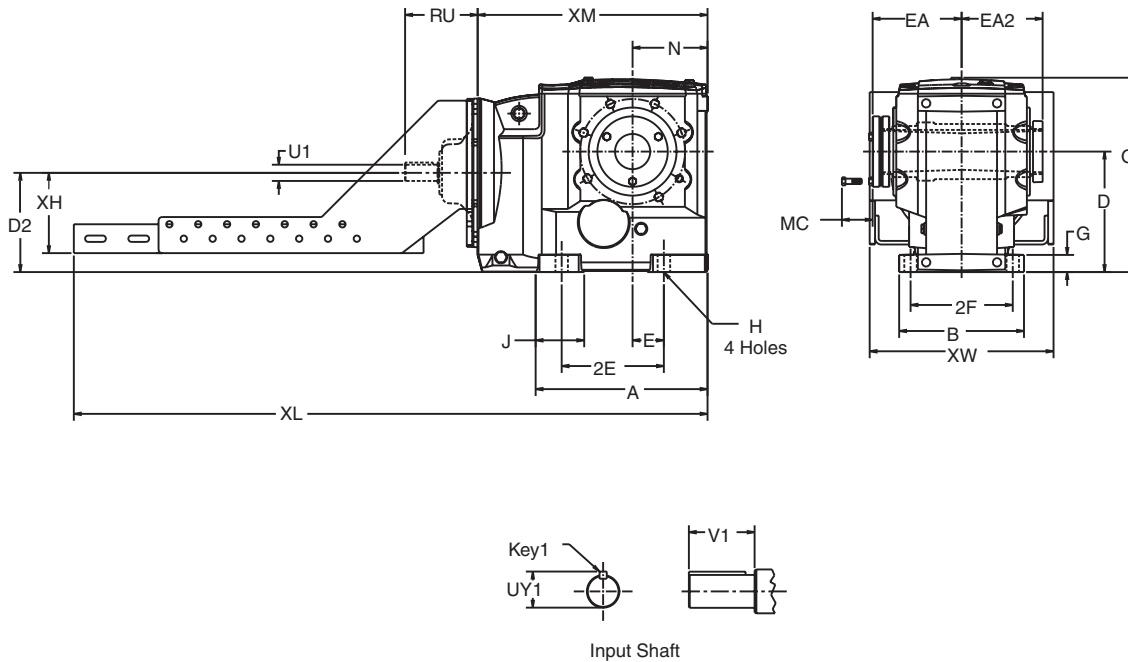

OtN Series

Gear Frame	Version	A	B	D <sup>1</sup>	D2	E	2E	2F	G	H	J	O	N	XM
33 (A)	S2	8.50	6.61	5.51	5.24	1.18	4.72	5.51	.85	.55	2.86	9.69	3.54	11.97
34	S2	10.13	7.87	7.09	5.90	1.57	5.91	6.50	1.07	.71	2.67	12.05	4.49	13.78
35	S2	11.92	8.66	8.35	6.89	2.17	7.09	7.09	1.18	.87	3.45	13.58	5.2	15.95

### Output Shaft

Gear Frame	Version	EA	EA2	MC <sup>5</sup>	Bushing Bores <sup>4</sup>	
					Min.	Max.
33	S2	4.82	4.23	1.75	3/4	1 7/16
33A	S2	5.76	5.18	1.88	1 7/16	1 15/16
34	S2	5.84	5.27	1.88	15/16	1 15/16
35	S2	6.17	5.620	1.88	1 3/8	2 7/16

### Input Shaft

Gear Frame	Version	RU	U1 <sup>3</sup>	UY1	V1	Key1
33	S2	3.17	.625	.705	1.25	3/16 Sq.
34	S2	4.75	1.125	1.236	2.25	1/4 Sq.
35	S2	5.03	1.125	1.236	2.25	1/4 Sq.

### Motor Frame

Gear Frame	143T-145T			182T-184T			213T-215T		
	XH	XL	XW	XH	XL	XW	XH	XL	XW
33 (A)	3.75	30.25	11.38	-	-	-	-	-	-
34	4.74	39.25	12.38	4.74	39.25	12.38	-	-	-
35	5.50	42.61	12.75	5.50	41.61	12.75	5.50	42.01	12.75

<sup>1</sup> Dimension "D" will never be exceeded, but may vary from values shown. When exact dimensions are required, shims up to .03" may be necessary.

<sup>2</sup> All rough casting dimensions may vary by .25" due to casting variations.

<sup>3</sup> Input shaft extension tolerances: +.0000"; -.0005" for shafts up to 1.5" diameter. Larger diameter "U1", +.000"; -.001".

<sup>4</sup> Refer to page B-133 by gear frame for listing of all inch and metric bushing bore sizes available.

<sup>5</sup> The MC dimension shows spacing required to install or remove the bushing from the reducer.

<sup>6</sup> Bushing and dust cap can be installed opposite of how they are shown above.

<sup>7</sup> Driven shaft entry can be from either side of the gear reducer housing. Refer to installation manual for requirements.

<sup>8</sup> For details of the torque arm kit, refer to page B-129.

## 3-Stage Taper Bushed Shaft Mount

### OtN36 - 38

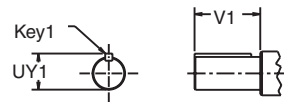
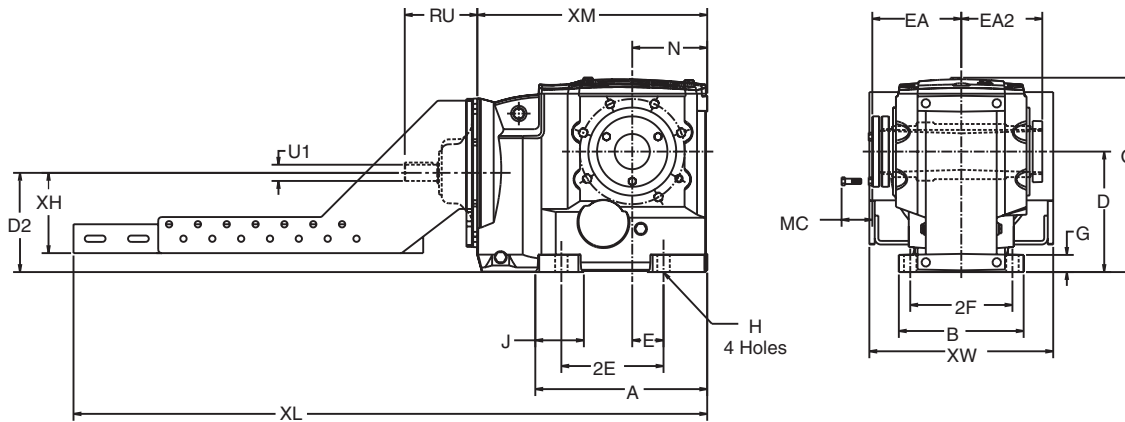

Input Shaft

Gear Frame	Version	A	B	D <sup>1</sup>	D2	E	2E	2F	G	H	J	O	N	XM
36	S2	17.06	11.41	8.86	8.86	6.99	13.98	9.45	1.57	.87	3.87	16.26	8.74	23.11
37	S2	20.58	12.99	9.84	10.98	8.27	16.54	10.63	1.93	.94	4.78	18.29	10.04	28.44
38	S2	17.85	13.39	14.76	11.87	4.53	13.78	10.63	1.98	1.26	4.06	24.11	8.86	24.02

#### Output Shaft

Gear Frame	Version	EA	EA2	MC <sup>5</sup>	Bushing Bores <sup>4</sup>	
					Min.	Max.
36	S2	6.81	7.83	1.88	2 7/16	2 15/16
37	S2	9.50	8.86	2.25	2 7/8	3 7/16
38	S2	8.66	8.08	2.75	2 15/16	3 15/16

#### Input Shaft

Gear Frame	RU	U1 <sup>3</sup>	UY1	V1	Key1
36	7.56	1.875	2.101	3.75	1/2 Sq.
37	7.56	1.875	2.101	3.75	1/2 Sq.
38	7.56	1.875	2.101	3.75	1/2 Sq.

#### Motor Frame

Gear Frame	182T-184T			213T-215T			254T-256T			284T-286T			324T-326T		
	XH	XL	XW	XH	XL	XW	XH	XL	XW	XH	XL	XW	XH	XL	XW
36	6.63	55.06	15.00	6.63	55.06	15.00	6.63	55.06	15.00	8.50	59.06	19.06	8.50	59.06	19.06
37	6.63	60.4	15.00	6.63	60.4	15.00	6.63	60.4	15.00	8.50	64.4	19.06	8.50	64.4	19.06
38	-	-	-	-	-	-	8.50	59.93	19.06	8.50	58.93	19.06	9.50	60.93	21.31

<sup>1</sup> Dimension "D" will never be exceeded, but may vary from values shown. When exact dimensions are required, shims up to .03" may be necessary.

<sup>2</sup> All rough casting dimensions may vary by .25" due to casting variations.

<sup>3</sup> Input shaft extension tolerances: +.0000"; -.0005" for shafts up to 1.5" diameter. Larger diameter "U1", +.000"; -.001".

<sup>4</sup> Refer to page B-133 by gear frame for listing of all inch and metric bushing bore sizes available.

<sup>5</sup> The MC dimension shows spacing required to install or remove the bushing from the reducer.

<sup>6</sup> Bushing and dust cap can be installed opposite of how they are shown above.

<sup>7</sup> Driven shaft entry can be from either side of the gear reducer housing. Refer to installation manual for requirements.

<sup>8</sup> For details of the torque arm kit, refer to page B-129.

## 3-Stage CEMA Screw Conveyor Drive OtN33 - 35

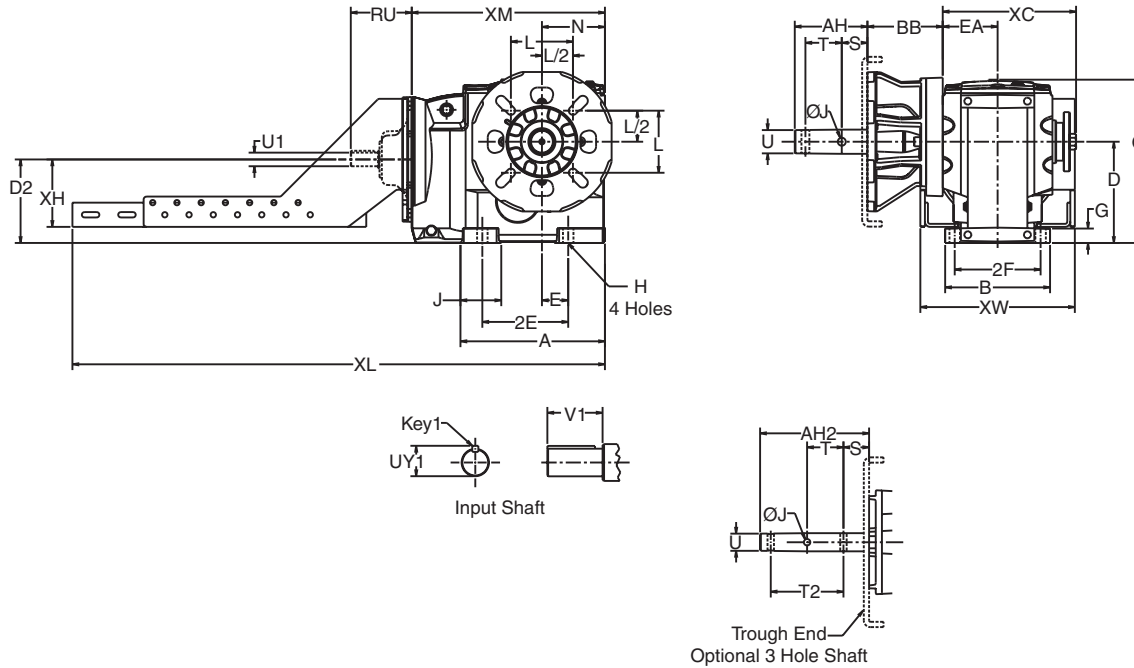

OtN Series

Gear Frame	Version	A	B	D <sup>1</sup>	D2	E	2E	2F	G	H	J	O	N	EA	XC	XM
33	S2	8.50	6.61	5.51	5.24	1.18	4.72	5.51	.85	.55	2.86	9.69	3.54	3.35	8.30	11.97
34	S2	10.13	7.87	7.09	5.90	1.57	5.91	6.50	1.07	.71	2.67	12.05	4.49	4.07	9.84	13.78
35	S2	11.92	8.66	8.35	6.89	2.17	7.09	7.09	1.18	.87	3.37	13.58	5.20	4.43	11.00	15.95

### Screw Conveyor

Gear Frame	Screw Dia.	J	L	U	S	T	T2	AH	AH2	BB
33	6 - 10	.53	4.00	1.50	2.13	3.00	6.00	6.00	9.00	5.13
	9 - 12	.66	5.13	2.00	2.13	3.00	6.00	6.00	9.00	5.13
	12 - 14	.66	5.63	2.44	2.75	3.00	6.00	6.00	9.69	5.13
	12 - 20	.78	6.00	3.00	2.88	3.00	6.00	6.88	9.88	5.13
34	6 - 10	.53	4.00	1.50	2.13	3.00	6.00	6.00	9.00	5.13
	9 - 12	.66	5.13	2.00	2.13	3.00	6.00	6.00	9.00	5.13
	12 - 14	.66	5.63	2.44	2.75	3.00	6.00	6.00	9.69	5.13
	12 - 20	.78	6.00	3.00	2.88	3.00	6.00	6.88	9.88	5.13
35	9 - 12	.66	5.13	2.00	2.13	3.00	6.00	6.00	9.00	6.21
	12 - 14	.66	5.63	2.44	2.75	3.00	6.00	6.69	9.69	6.21
	12 - 20	.78	6.00	3.00	2.88	3.00	6.00	6.88	9.88	6.21
	18 - 24	.91	6.75	3.44	3.88	4.00	-	9.13	-	6.21

Gear Frame	Version	RU	U1 <sup>5</sup>	UY1	V1	Key1
33	S2	3.17	.625	.705	1.25	3/16 Sq.
34	S2	4.75	1.125	1.236	2.25	1/4 Sq.
35	S2	5.03	1.125	1.236	2.25	1/4 Sq.

### Motor Frame

Gear Frame	143T-145T			182T-184T			213T-215T		
	XH	XL	XW	XH	XL	XW	XH	XL	XW
33	3.75	30.25	11.38	-	-	-	-	-	-
34	4.74	39.25	12.38	4.74	39.25	12.38	-	-	-
35	5.50	42.61	12.75	5.50	41.61	12.75	5.50	42.01	12.75

<sup>1</sup> Dimension "D" will never be exceeded, but may vary from values shown. When exact dimensions are required, shims up to .03" may be necessary.  
<sup>2</sup> All rough casting dimensions may vary by .25" due to casting variations.

<sup>3</sup> Refer to pages B-131 and B-132 for the screw conveyor drive shafts, trough ends and other accessories available for each gear frame size.

<sup>4</sup> Thrust ratings for each gear frame size are listed on page B-131.

<sup>5</sup> Input shaft extension tolerances: +.0000"/-.0005" up to 1.5" diameter; large diameters +.000"/-.001".

## 3-Stage CEMA Screw Conveyor Drive OtN36 - 37

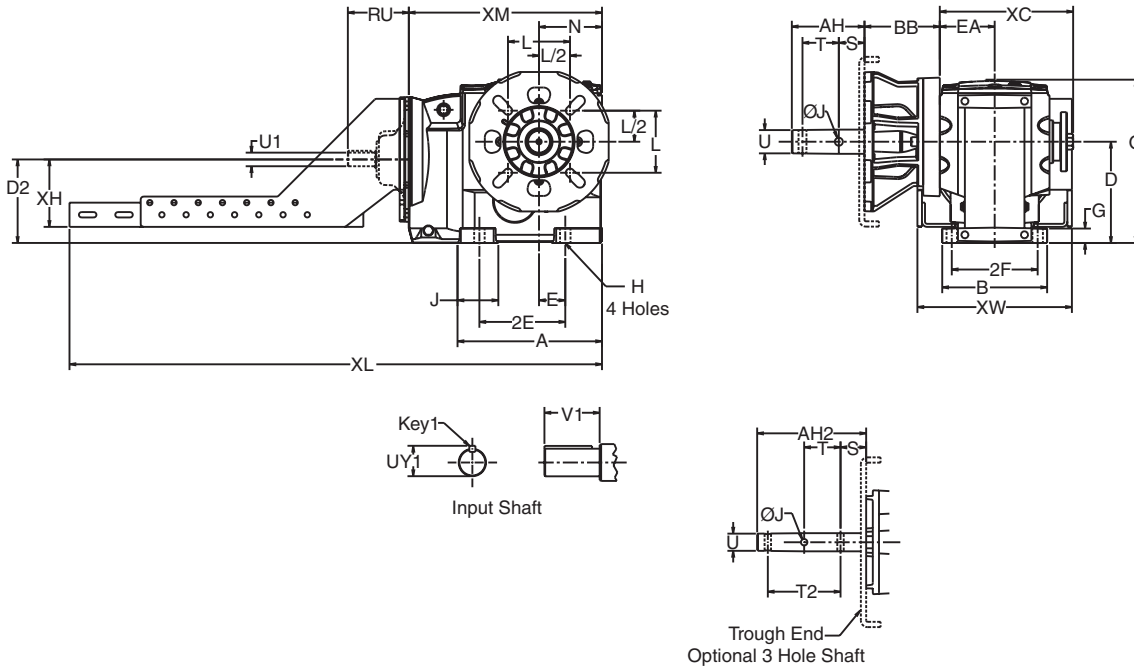

# OtN Series

Gear Frame	Version	A	B	D <sup>1</sup>	D2	E	2E	2F	G	H	J	O	N	EA	XC	XM
36	S2	17.06	11.41	8.86	8.86	6.99	13.98	9.45	1.57	.87	3.87	16.26	8.74	6.02	13.14	23.11
37	S2	20.58	12.99	9.84	10.98	8.27	16.54	10.63	1.93	.94	4.78	18.29	10.04	6.61	14.76	28.44

### Screw Conveyor

Gear Frame	Screw Dia.	JJ	L	U	S	T	T2	AH	AH2	BB
36	9-12	.66	5.13	2.00	2.13	3.00	6.00	6.00	9.00	6.67
	12, 14	.66	5.63	2.44	2.75	3.00	6.00	6.69	9.69	6.67
	12-20	.78	6.00	3.00	2.88	3.00	6.00	6.88	9.88	6.67
	18-24	.91	6.75	3.44	3.88	4.00	8.00	9.13	13.13	6.67
37	12-20	.78	6.00	3.00	2.88	3.00	6.00	6.88	9.88	7.94
	18-24	.91	6.75	3.44	3.88	4.00	8.00	9.13	13.13	7.94

### Input Shaft

Gear Frame	RU	U1 <sup>5</sup>	UY1	V1	Key1
36	7.56	1.875	2.101	3.75	1/2 Sq.
37	7.56	1.875	2.101	3.75	1/2 Sq.

### Motor Frame

Gear Frame	182T-184T			213T-215T			254T-256T			284T-286T			324T-326T		
	XH	XL	XW	XH	XL	XW	XH	XL	XW	XH	XL	XW	XH	XL	XW
36	6.63	55.06	15.00	6.63	55.06	15.00	6.63	55.06	15.00	8.50	59.06	19.06	8.50	59.06	19.06
37	6.63	60.4	15.00	6.63	60.4	15.00	6.63	60.4	15.00	8.50	64.4	19.06	8.50	64.4	19.06

<sup>1</sup> Dimension "D" will never be exceeded, but may vary from values shown. When exact dimensions are required, shims up to .03" may be necessary.

<sup>2</sup> All rough casting dimensions may vary by .25" due to casting variations.

<sup>3</sup> Refer to pages B-131 and B-132 for the screw conveyor drive shafts, trough ends and other accessories available for each gear frame size.

<sup>4</sup> Thrust ratings for each gear frame size are listed on page B-131.

<sup>5</sup> Input shaft extension tolerances: +.0000"/-.0005" up to 1.5" diameter; large diameters +.000"/-.001".



## 2-Stage Output Shafted Foot Mount OtN32

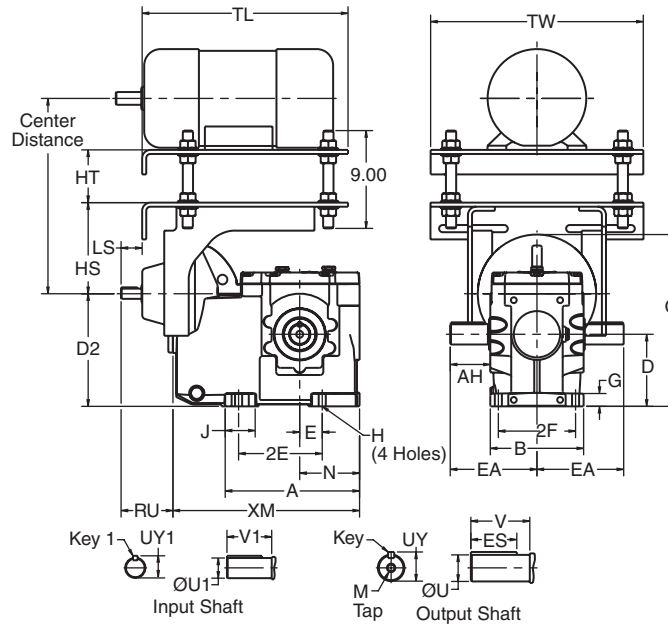

OtN Series

Gear Frame	Version	A	B	D <sup>1</sup>	D2	E	2E	2F	G	H	J	O	N	XM	LS	HS	HT	TL	TW
3242	S2	8.22	5.71	4.41	6.89	1.38	5.12	4.72	.79	.43	1.83	10.51	3.66	12.36	1.29	7.14	6.00	15.5	16.5

### Output Shaft

Gear Frame	Version	U <sup>3</sup>	UY	V	AH	EA	Key	ES	M
3242	S2	1.250	1.35	2.38	2.45	5.31	1/4 Sq.	2.03	1/2-13 X 1.12

### Input Shaft

Gear Frame	Version	RU	U1 <sup>4</sup>	UY1	V1	Key1
3242	S2	3.17	.625	.705	1.25	3/16 Sq.

Motor Frame	Center Distance	
	Min.	Max.
56	12.28	18.25
B56	12.28	18.25
182T/184T	13.28	19.25

<sup>1</sup> Dimension "D" will never be exceeded, but may vary from values shown. When exact dimensions are required, shims up to .03" may be necessary.

<sup>2</sup> All rough casting dimensions may vary by .25" due to casting variations.

<sup>3</sup> Output shaft extension tolerances: +.0000"; -.0005" for shafts up to 1.5" diameter "U". Larger diameter "U", +.000"; -.001".

<sup>4</sup> Input shaft extension tolerances: +.0000"; -.0005" up to 1.5" diameter. Larger diameter "U1", +.000"; -.001".

## 3-Stage Output Shafted Foot Mount OtN33 - 35

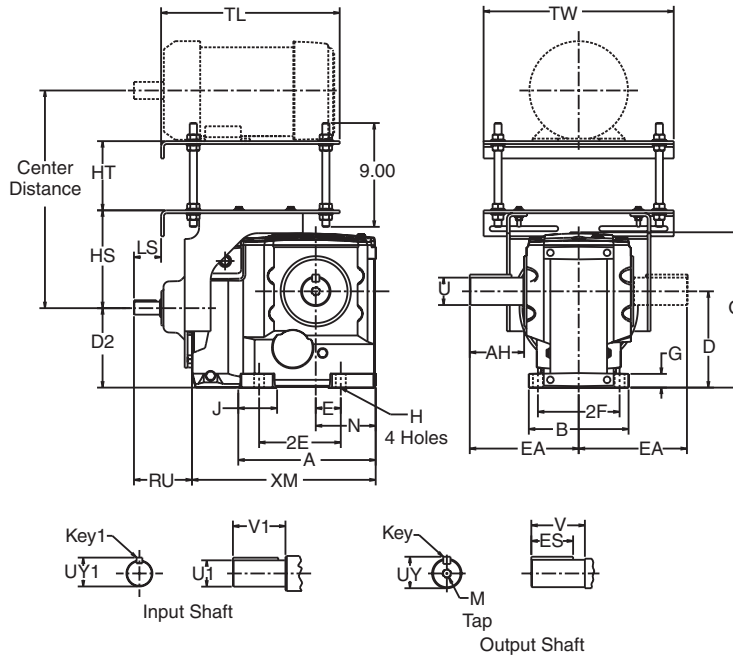

OtN Series

Gear Frame	Version	A	B	D'	D2	E	2E	2F	G	H	J	O	N	XM	LS	HS	HT	TL	TW
33	S2	8.50	6.61	5.51	5.24	1.18	4.72	5.51	.85	.55	2.86	9.69	3.54	11.97	1.29	7.14	6.00	15.50	16.50
	S1	8.08	8.58	4.92	5.20	3.35	6.69	6.10	.79	.55	2.27	10.43	3.54	11.97					
34	S2	10.13	7.87	7.09	5.90	1.57	5.91	6.50	1.07	.71	2.67	12.05	4.49	13.78	2.31	7.17	6.00	15.50	16.50
	S1	10.69	9.60	6.30	7.49	4.53	9.06	7.68	1.18	.71	3.19	13.39	4.49	13.78					
35	S2	11.92	8.66	8.35	6.89	2.17	7.09	7.09	1.18	.87	3.37	13.58	5.20	15.95	2.35	8.48	6.00	15.50	16.50
	S1	13.07	10.98	7.87	9.33	5.51	11.02	9.06	1.40	.87	4.05	16.22	5.20	15.95					

### Output Shaft

Gear Frame	Version	U <sup>3</sup>	UY	V	AH	EA	Key	ES	M
33	S2	1.625	1.783	3.25	3.39	6.73	3/8 Sq.	2.78	5/8-11 X 1.38
	S1	1.500	1.657	3.18	3.19	7.12	3/8 Sq.	2.78	5/8-11 X 1.38
34	S2	2.000	2.210	3.63	3.76	8.11	1/2 Sq.	3.06	3/4-10 X 1.61
	S1	1.750	1.909	3.56	3.66	8.46	3/8 Sq.	3.56	3/4-10 X 1.61
35	S2	2.375	2.638	4.61	4.74	9.45	5/8 Sq.	3.81	3/4-10 X 1.61
	S1	2.375	2.638	5.73	5.27	10.57	5/8 Sq.	4.81	3/4-10 X 1.61

### Input Shaft

Gear Frame	Version	RU	U1 <sup>4</sup>	UY1	V1	Key1
33	S1,S2	3.17	.625	.70	1.25	3/16 Sq.
34	S1,S2	4.75	1.125	1.24	2.25	1/4 Sq.
35	S1,S2	5.03	1.125	1.24	2.25	1/4 Sq.

Motor Frame	33		34		35	
	Center Distance		Center Distance		Center Distance	
	Min.	Max.	Min.	Max.	Min.	Max.
56	12.28	18.25	12.31	18.28	-	-
143T/145T	12.28	18.25	12.31	18.28	13.87	19.34
182T/184T	13.28	19.25	13.31	19.28	14.87	20.34
213T/215T	-	-	14.06	20.03	15.62	21.09
254T/256T	-	-	-	-	16.62	22.09

<sup>1</sup> Dimension "D" will never be exceeded, but may vary from values shown. When exact dimensions are required, shims up to .03" may be necessary.

<sup>2</sup> All rough casting dimensions may vary by .25" due to casting variations.

<sup>3</sup> Output shaft extension tolerances: +.0000"; -.0005" for shafts up to 1.5" diameter "U". Larger diameter "U", +.000"; -.001".

<sup>4</sup> Input shaft extension tolerances: +.0000"; -.0005" up to 1.5" diameter. Larger diameter "U1", +.000"; -.001".

## 3-Stage Output Shafted Foot Mount OtN36 - 38

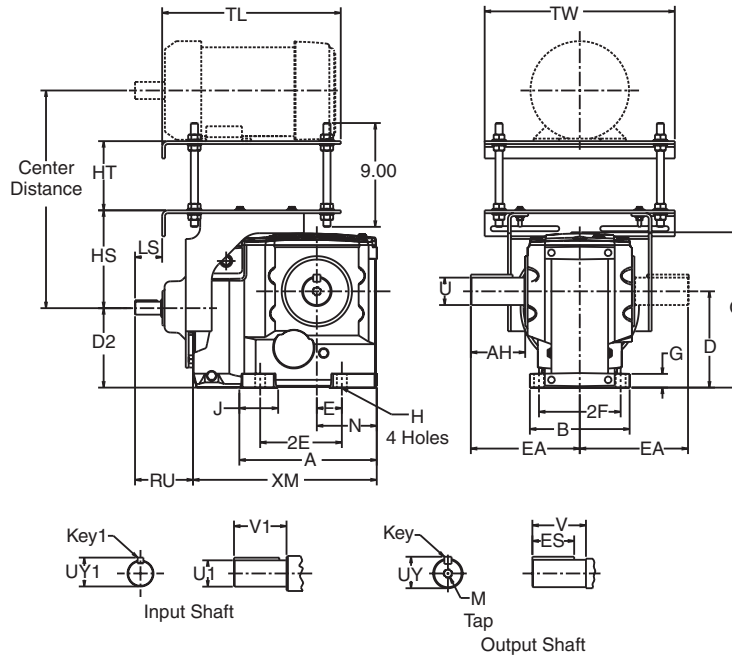

Gear Frame	Version	A	B	D <sup>1</sup>	D2	E	2E	2F	G	H	J	O	N	XM
36	S1	17.06	11.41	8.86	8.86	6.99	13.98	9.45	1.57	.87	3.87	16.26	8.74	23.11
37	S1	20.58	12.99	9.84	10.98	8.27	16.54	10.63	1.93	.94	4.78	18.29	10.04	28.44
38	S2	17.85	13.39	14.76	11.87	4.53	13.78	10.63	1.98	1.26	4.06	24.11	8.86	24.02

### Output Shaft

Gear Frame	Version	U <sup>3</sup>	UY	V	AH	EA	Key	ES	M
36	S1	2.875	3.20	5.75	5.92	11.94	3/4 SQ.	5.00	3/4-10 X 1.61
37	S1	3.625	4.01	6.86	7.04	13.66	7/8 SQ.	6.00	1-8 X 2.13
38	S2	4.375	4.809	8.99	9.97	17.03	1.00 SQ.	7.00	1-8 X 2.25

### Input Shaft

Gear Frame	RU	U1 <sup>4</sup>	UY1	V1	Key1
36	7.56	1.875	2.101	3.75	1/2 Sq.
37	7.56	1.875	2.101	3.75	1/2 Sq.
38	7.56	1.875	2.101	3.75	1/2 Sq.

### Top Mount

Gear Frame	LS	HS	HT		TL	TW
			Min.	Max.		
36	3.76	10.48	1.89	7.36	20.25	24.00
37	3.76	10.48	1.89	7.36	20.25	24.00
38	4.71	19.38	1.89	7.36	19.38	24.00

Motor Frame	36		37		38	
	Center Distance	Center Distance	Center Distance	Center Distance	Center Distance	Center Distance
182T/184T	Min. 16.73	Max. 22.73	Min. 16.73	Max. 22.73	Min. 25.78	Max. 31.25
213T/215T	17.48	23.48	17.48	23.48	26.53	32.00
254T/256T	18.48	24.48	18.48	24.48	27.53	33.00
284T/286T	19.23	25.23	19.23	25.23	28.28	33.75
324T/326T	20.23	26.23	20.23	26.23	29.28	34.75

<sup>1</sup> Dimension "D" will never be exceeded, but may vary from values shown. When exact dimensions are required, shims up to .03" may be necessary.  
<sup>2</sup> All rough casting dimensions may vary by .25" due to casting variations.

<sup>3</sup> Output shaft extension tolerances: +.0000"; -.0005" for shafts up to 1.5" diameter "U". Larger diameter "U", +.000"; -.001".  
<sup>4</sup> Input shaft extension tolerances: +.0000"; -.0005" up to 1.5" diameter. Larger diameter "U1", +.000"; -.001".

## 2-Stage Finished Bore Hollow Shaft OtN32

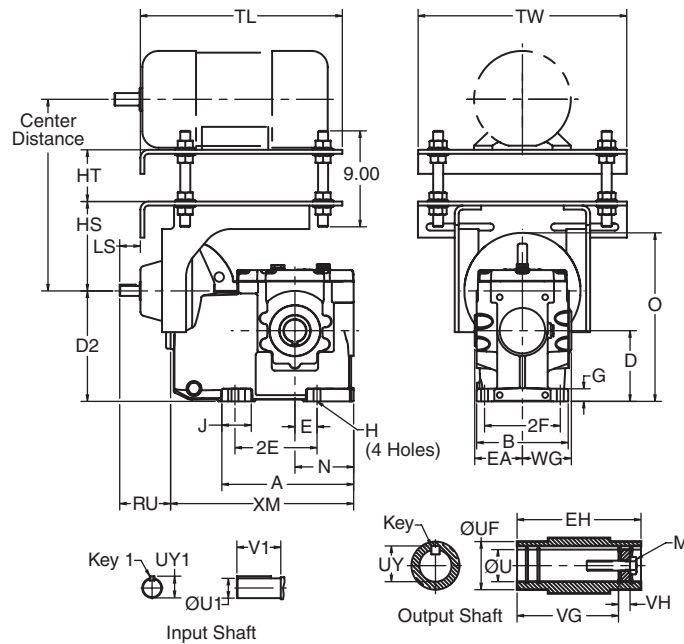

Gear Frame	Version	A	B	D <sup>1</sup>	D2	E	2E	2F	G	H	J	O	N	WG	XM	LS	HS	HT	TL	TW
3242	S2	8.22	5.71	4.41	6.89	1.38	5.12	4.72	.79	.43	1.83	10.51	3.66	3.22	12.36	1.29	7.14	6.00	15.5	16.5

### Output Shaft

Gear Frame	Version	EA	EH	U <sup>3 7</sup>	UF	UY	VG	VH	Key <sup>5</sup>	M
3242	S2	2.97	5.94	1.375	1.96	1.523	5.06	.37	5/16 X 5/16 1 13/16	1/2-13 X 1.00

### Input Shaft

Gear Frame	Version	RU	U <sup>1 4</sup>	UY1	V1	Key1
3242	S2	3.17	.625	.705	1.25	3/16 Sq.

Motor Frame	Center Distance	
	Min.	Max.
56	12.28	18.25
B56	12.28	18.25
182T/184T	13.28	19.25

<sup>1</sup> Dimension "D" will never be exceeded, but may vary from values shown. When exact dimensions are required, shims up to .03" may be necessary.

<sup>2</sup> All rough casting dimensions may vary by .25" due to casting variations.

<sup>3</sup> Driven shaft entry can be from either side of the gear reducer housing by reversing positioning of the snap rings and washer illustrated.

<sup>4</sup> Output finished bore tolerance: +.0020", -.0000 for all diameters.

<sup>5</sup> Output key supplied only on frame 34 "S2" version.

<sup>6</sup> Input shaft extension tolerances: +.0000"; -.0005" up to 1.5" diameter. Larger diameter "U1", +.000"; -.001".

<sup>7</sup> Refer to Tapered Bushed designs if driven shaft varies from "U" dimensions offered above.

<sup>8</sup> For details of the torque arm kit, refer to page B-129.

## 3-Stage Finished Bore Hollow Shaft OtN33 - 35

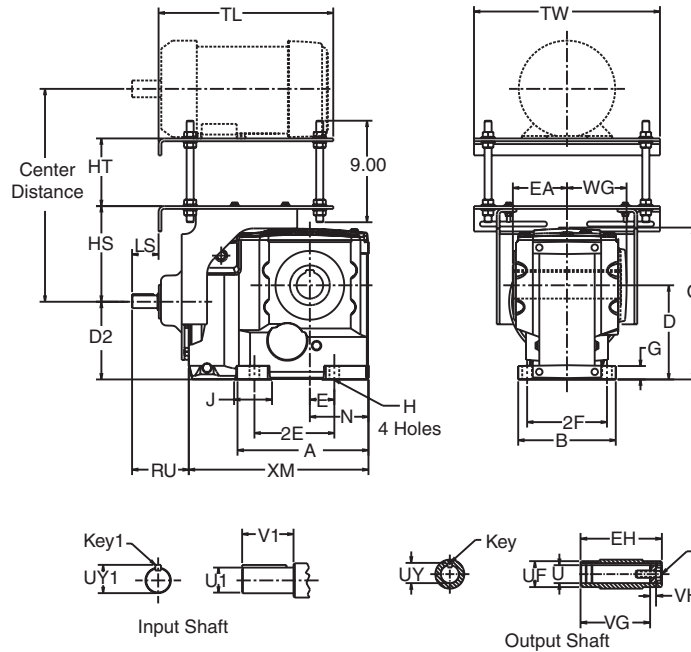

OtN Series

Gear Frame	Version	A	B	D <sup>1</sup>	D2	E	2E	2F	G	H	J	O	N	WG	XM	LS	HS	HT	TL	TW
33	S2	8.50	6.61	5.51	5.24	1.18	4.72	5.51	.85	.55	2.86	9.69	3.54	3.73	11.97	1.29	7.14	6.00	15.50	16.50
34	S2	10.13	7.87	7.09	5.90	1.57	5.91	6.50	1.07	.71	2.67	12.05	4.49	4.66	13.78	2.31	7.17	6.00	15.50	16.50
35	S2	11.92	8.66	8.35	6.89	2.17	7.09	7.09	1.18	.87	3.45	13.58	5.20	5.15	15.95	2.35	8.48	6.00	15.50	16.50

### Output Shaft

Gear Frame	Version	EA	EH	U <sup>4,7</sup>	UF	UY	VG	VH	Key <sup>5</sup>	M
33	S2	3.47	6.94	1.500	2.16	1.674	5.96	.55	3/8 X 3/8 X 2 1/4	5/8-11 X 1.75
34	S2	4.49	8.97	2.000	2.56	2.210	7.44	.79	1/2 X 7/16 X 2 5/8	5/8-11 X 1.75
35	S2	4.83	9.66	2.375	3.54	2.656	8.15	.94	5/8 X 5/8 X 3 5/8	3/4-10 X 2.00

### Input Shaft

Gear Frame	Version	RU	U1 <sup>6</sup>	UY1	V1	Key1
33	S2	3.17	.625	.70	1.25	3/16 Sq.
34	S2	4.75	1.125	1.24	2.25	1/4 Sq.
35	S2	5.03	1.125	1.24	2.25	1/4 Sq.

Motor Frame	33		34		35	
	Center Distance		Center Distance		Center Distance	
	Min.	Max.	Min.	Max.	Min.	Max.
56	12.28	18.25	12.31	18.28	-	-
143T/145T	12.28	18.25	12.31	18.28	13.87	19.34
182T/184T	13.28	19.25	13.31	19.28	14.87	20.34
213T/215T	-	-	14.06	20.03	15.62	21.09
254T/256T	-	-	-	-	16.62	22.09

<sup>1</sup> Dimension "D" will never be exceeded, but may vary from values shown. When exact dimensions are required, shims up to .03" may be necessary.

<sup>2</sup> All rough casting dimensions may vary by .25" due to casting variations.

<sup>3</sup> Driven shaft entry can be from either side of the gear reducer housing by reversing positioning of the snap rings and washer illustrated.

<sup>4</sup> Output finished bore tolerance: +.0020", -.0000 for all diameters.

<sup>5</sup> Output key supplied only on frame 34 "S2" version.

<sup>6</sup> Input shaft extension tolerances: +.0000"; -.0005" up to 1.5" diameter. Larger diameter "U1", +.000"; -.001".

<sup>7</sup> Refer to Tapered Bushed designs if driven shaft varies from "U" dimensions offered above.

<sup>8</sup> For details of the torque arm kit, refer to page B-129.

## 3-Stage Finished Bore Hollow Shaft OtN36 - 38

# OtN Series

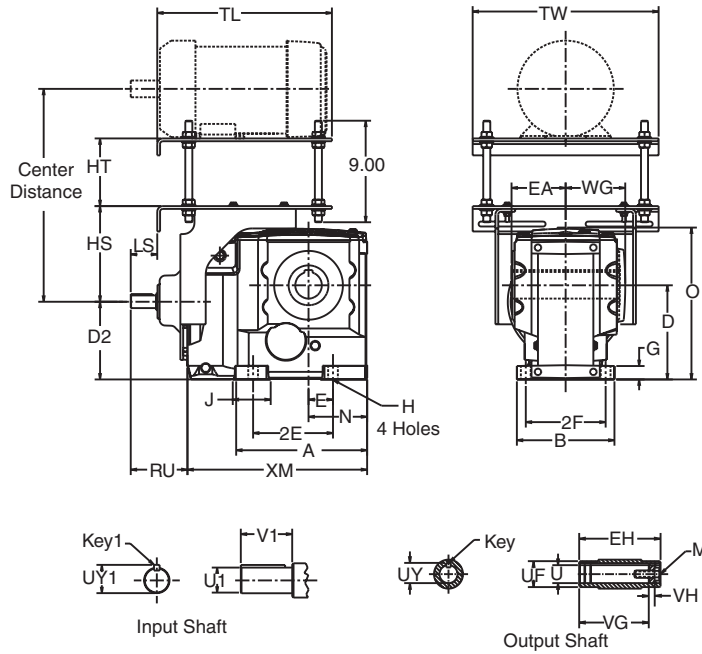

Gear Frame	Version	A	B	D <sup>1</sup>	D2	E	2E	2F	G	H	J	O	N	XM
36	S2	17.06	11.41	8.86	8.86	6.99	13.98	9.45	1.57	.87	3.87	16.26	8.74	23.11
37	S2	20.58	12.99	9.84	10.98	8.27	16.54	10.63	1.93	.94	4.78	18.29	10.04	28.44
38	S2	17.85	13.39	14.76	11.87	4.53	13.78	10.63	1.98	1.26	4.06	24.11	8.86	24.02

### Output Shaft

Gear Frame	Version	EA	EH	U <sup>4,7</sup>	UF	UY	VG	VH	Key <sup>5</sup>	M
36	S2	6.22	12.44	2.750	3.93	3.037	10.89	1.23	5/8 x 5/8 x 5 1/2	3/4 - 10 x 2.00
37	S2	6.22	13.59	3.625	4.72	4.019	11.90	1.23	7/8 x 7/8 x 5 1/2	3/4 - 10 x 2.00
38	S2	6.81	13.74	4.000	5.50	4.316	11.86	.92	1 x 1 x 6 1/2	1 - 8 x 2.25

### Input Shaft

Gear Frame	Version	RU	U1 <sup>5</sup>	UY1	V1	Key1
36	S2	7.56	1.875	2.101	3.75	1/2 Sq.
37	S2	7.56	1.875	2.101	3.75	1/2 Sq.
38	S2	7.56	1.875	2.101	3.75	1/2 Sq.

### Top Mount

Gear Frame	LS	HS	HT		TL	TW
			Min.	Max.		
36	3.76	10.48	1.89	7.36	20.25	24.00
37	3.76	10.48	1.89	7.36	20.25	24.00
38	4.71	19.38	1.89	7.36	19.38	24.00

Motor Frame	36		37		38	
	Center Distance		Center Distance		Center Distance	
	Min.	Max.	Min.	Max.	Min.	Max.
36	1.89	7.36	1.89	7.36	1.89	7.36
37	1.89	7.36	1.89	7.36	1.89	7.36
38	1.89	7.36	1.89	7.36	1.89	7.36

<sup>1</sup> Dimension "D" will never be exceeded, but may vary from values shown. When exact dimensions are required, shims up to .03" may be necessary.

<sup>2</sup> All rough casting dimensions may vary by .25" due to casting variations.

<sup>3</sup> Output shaft extension tolerances: +.0000";-.0005" for shafts up to 1.5" diameter "U". Larger diameter "U", +.000";-.001".

<sup>4</sup> Input shaft extension tolerances: +.0000";-.0005" up to 1.5" diameter. Larger diameter "U1", +.000";-.001".

## 3-Stage Finished Bore Hollow Shaft Face Mount OtN33 - 35

OtN Series

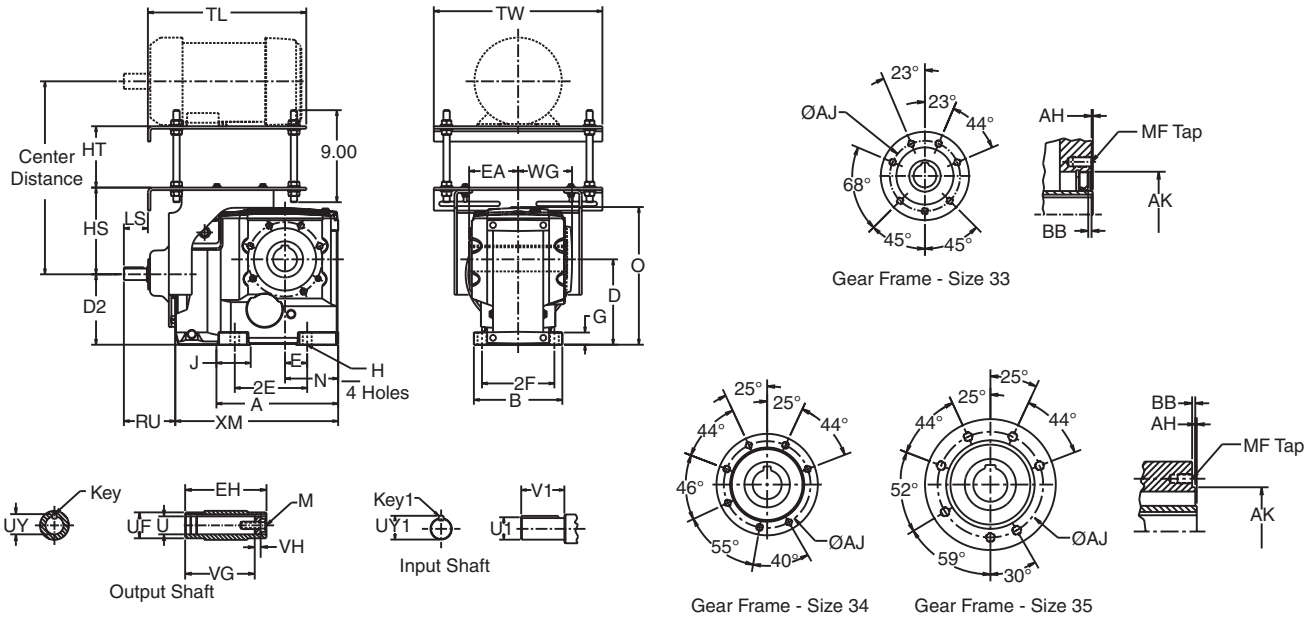

Gear Frame	Version	A	B	D <sup>1</sup>	D <sub>2</sub>	E	2E	2F	G	H	J	O	N	WG	XM	LS	HS	HT	TL	TW
33	S2	8.50	6.61	5.51	5.24	1.18	4.72	5.51	.85	.55	2.86	9.69	3.54	3.63	11.97	1.29	7.14	6.00	15.50	16.50
34	S2	10.13	7.87	7.09	5.90	1.57	5.91	6.50	1.07	.71	2.67	12.05	4.49	4.66	13.78	2.31	7.17	6.00	15.50	16.50
35	S2	11.92	8.66	8.35	6.89	2.17	7.09	7.09	1.18	.87	3.45	13.58	5.20	5.15	15.95	2.35	8.48	6.00	15.50	16.50

### Output Shaft

Gear Frame	Version	EA	EH	U <sup>5</sup>	UF	UY	VG	VH	Key <sup>4</sup>	M
33	S2	3.47	6.94	1.500	2.16	1.674	5.96	.55	3/8 X 3/8 X 2 1/4	5/8-11 X 1.75
34	S2	4.49	8.97	2.000	2.56	2.210	7.44	.79	1/2 X 7/16 X 2 5/8	5/8-11 X 1.75
35	S2	4.83	9.66	2.375	3.54	2.638	8.15	.94	5/8 X 5/8 X 3 5/8	3/4-10 X 2.00

### Output Face

Gear Frame	Version	AH	AJ	AK	BB	MF
33	S2	.12	4.84	3.94	.16	M12-1.75 X 22
34	S2	.14	5.98	5.12	.28	M12-1.75 X 22
35	S2	.13	7.48	6.10	.28	M16-2.00 X 27

### Input Shaft

Gear Frame	Version	RU	U <sup>1</sup> <sup>6</sup>	UY1	V1	Key1
33	S2	3.17	.625	.705	1.25	3/16 Sq.
34	S2	4.75	1.125	1.236	2.25	1/4 Sq.
35	S2	5.03	1.125	1.236	2.25	1/4 Sq.

Motor Frame	33		34		35	
	Center Distance		Center Distance		Center Distance	
	Min.	Max.	Min.	Max.	Min.	Max.
56	12.28	18.25	12.31	18.28	-	-
143T/145T	12.28	18.25	12.31	18.28	13.87	19.34
182T/184T	13.28	19.25	13.31	19.28	14.87	20.34
213T/215T	-	-	14.06	20.03	15.62	21.09
254T/256T	-	-	-	-	16.62	22.09

<sup>1</sup> Dimension "D" will never be exceeded, but may vary from values shown. When exact dimensions are required, shims up to .03" may be necessary.  
<sup>2</sup> All rough casting dimensions may vary by .25" due to casting variations.  
<sup>3</sup> Driven shaft entry can be from either side of the gear reducer housing by reversing positioning of the snap rings and washer illustrated.

<sup>4</sup> Output key supplied only on frame 34 "S2" version.  
<sup>5</sup> Output finished bore tolerance: +.0020", -.0000 for all diameters.  
<sup>6</sup> Input shaft extension tolerances: +.0000"; -.0005" up to 1.5" diameter. Larger diameter "U1", +.000"; -.001".



## 3-Stage Finished Bore Hollow Shaft Face Mount OtN36 - 38

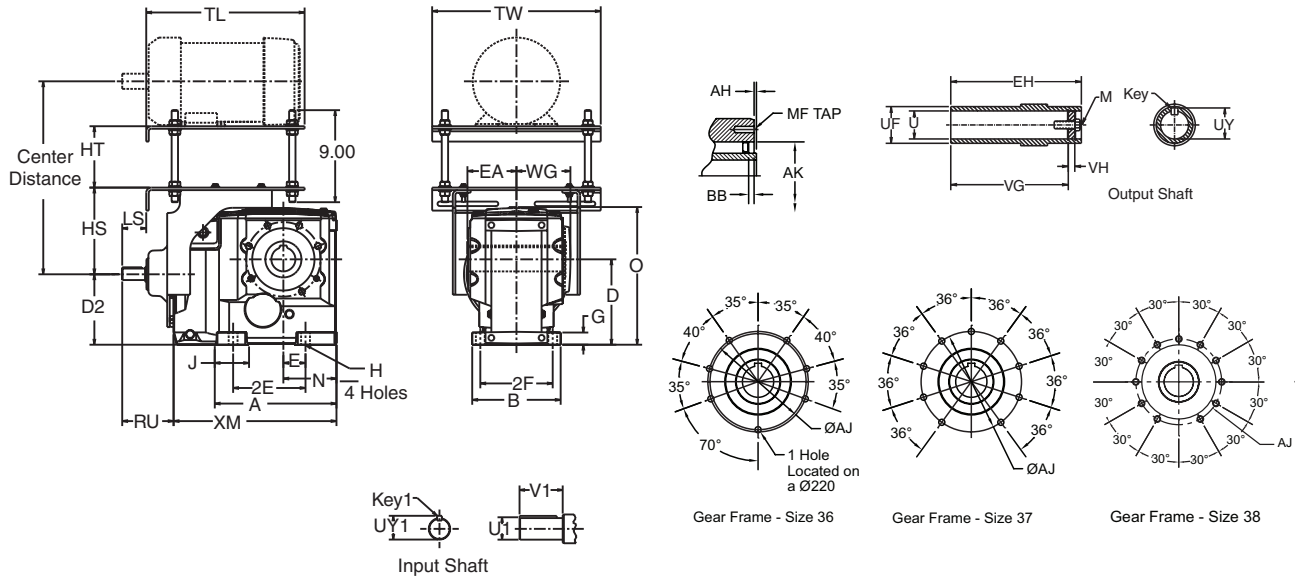

OtN Series

Gear Frame	Version	A	B	D <sup>1</sup>	D2	E	2E	2F	G	H	J	O	N	WG	XM
36	S2	17.06	11.41	8.86	8.86	6.99	13.98	9.45	1.57	.87	3.87	16.26	8.74	6.78	23.11
37	S2	20.58	12.99	9.84	10.98	8.27	16.54	10.63	1.93	.94	4.78	18.29	10.04	7.44	28.44
38	S2	17.85	13.39	14.76	11.87	4.53	13.78	10.63	1.98	1.26	4.06	24.11	8.86	7.40	24.02

### Output Shaft

Gear Frame	Version	EA	EH	U <sup>4</sup>	UF	UY	VG	VH	Key <sup>6</sup>	M
36	S2	6.22	12.44	2.750	3.93	3.037	10.89	1.23	5/8 x 5/8 x 5 1/2	3/4-10 x 2.00
37	S2	6.80	13.59	3.625	4.72	4.019	11.90	1.23	7/8 x 7/8 x 5 1/2	3/4-10 x 2.00
38	S2	6.81	13.74	4.000	5.50	4.316	11.86	.92	1 x 1 x 6 1/2	1-8 x 2.25

### Output Face

Gear Frame	Version	AH	AJ	AK	BB	BF
36	S2	-	9.06	5.91	.28	M16-2.0 x 27
37	S2	-	9.06	7.09	.28	M20-2.5 x 35
38	S2	.10	11.81	9.84	.20	M20-2.00 x 25

### Input Shaft

Gear Frame	Version	RU	U1 <sup>5</sup>	UY1	V1	Key
36	S2	7.56	1.875	2.101	3.75	1/2 Sq.
37	S2	7.56	1.875	2.101	3.75	1/2 Sq.
38	S2	7.56	1.875	2.101	3.75	1/2 Sq.

### Top Mount

Gear Frame	LS	HS	HT		TL	TW
			Min.	Max.		
36	3.76	10.48	1.89	7.36	20.25	24.00
37	3.76	10.48	1.89	7.36	20.25	24.00
38	4.71	19.38	1.89	7.36	19.38	24.00

Motor Frame	36		37		38	
	Center Distance		Center Distance		Center Distance	
	Min.	Max.	Min.	Max.	Min.	Max.
182T/184T	16.73	22.73	16.73	22.73	25.78	31.25
213T/215T	17.48	23.48	17.48	23.48	26.53	32.00
254T/256T	18.48	24.48	18.48	24.48	27.53	33.00
284T/286T	19.23	25.23	19.23	25.23	28.28	33.75
324T/326T	20.23	26.23	20.23	26.23	29.28	34.75

<sup>1</sup> Dimension "D" will never be exceeded, but may vary from values shown. When exact dimensions are required, shims up to .03" may be necessary.

<sup>2</sup> All rough casting dimensions may vary by .25" due to casting variations.

<sup>3</sup> Driven shaft entry can be from either side of the gear reducer housing by reversing positioning of the snap rings and washer illustrated.

<sup>4</sup> Output finished bore tolerance: +.0020", -.0000 for all diameters.

<sup>5</sup> Input shaft extension tolerances: +.0000"; -.0005" up to 1.5" diameter. Larger diameter "U1", +.000"; -.001"

<sup>6</sup> Key not supplied with reducer.

## 2-Stage Bushed Shaft Mount OtN32

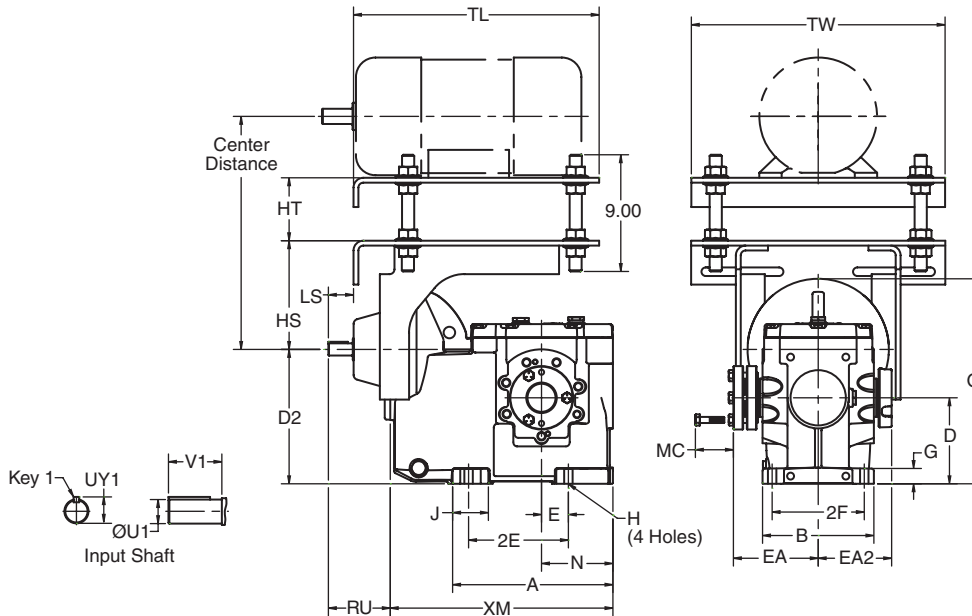

Gear Frame	Version	A	B	D <sup>1</sup>	D2	E	2E	2F	G	H	J	O	N	EA	XC	XM	LS	HS	HT	TL	TW
3242	S2	8.22	5.71	4.41	6.89	1.38	5.12	4.72	.79	.43	1.83	10.51	3.66	2.85	7.35	12.36	1.29	7.14	6.00	15.5	16.5

### Output Shaft

Gear Frame	Screw Dia.	JJ	L	U	S	T	T2	AH	AH2	BB
	3242	6-10	.53	4.00	1.50	2.13	3.00	6.00	6.00	9.00
	9-12	.66	5.13	2.00	2.13	3.00	6.00	6.00	9.00	5.13
	12-14	.66	5.63	2.44	2.75	3.00	6.00	6.00	9.69	5.13
	12-20	.78	6.00	3.00	2.88	3.00	6.00	6.88	9.88	5.13

### Input Shaft

Gear Frame	Version	RU	U1 <sup>5</sup>	UY1	V1	Key1
3242	S2	3.17	.625	.705	1.25	3/16 Sq.

Motor Frame	Center Distance	
	Min.	Max.
56	12.28	18.25
B56	12.28	18.25
182T/184T	13.28	19.25

<sup>1</sup> Dimension "D" will never be exceeded, but may vary from values shown. When exact dimensions are required, shims up to .03" may be necessary.

<sup>2</sup> All rough casting dimensions may vary by .25" due to casting variations.

<sup>3</sup> Input shaft extension tolerances: +.0000"; -.0005" up to 1.5" diameter. Larger diameter "U1", +.000"; -.001"

<sup>4</sup> Refer to page B-133 by gear frame for listing of all inch and metric bushing bore sizes available.

<sup>5</sup> The MC dimension shows spacing required to install or remove the bushing from the reducer.

<sup>6</sup> Bushing and dust cap can be installed opposite of how they are shown above.

<sup>7</sup> Driven shaft entry can be from either side of the gear reducer housing. Refer to installation manual for requirements.

<sup>8</sup> For details of the torque arm kit, refer to page B-129.

## 3-Stage Taper Bushed Shaft Mount OtN33 - 35

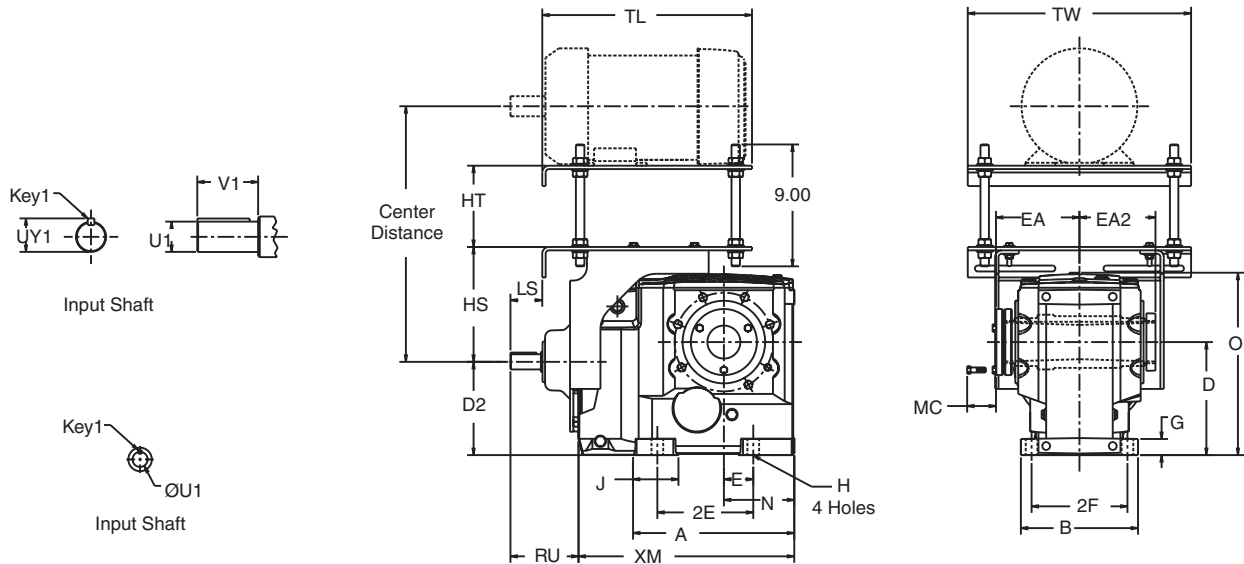

OtN Series

Gear Frame	Version	A	B	D <sup>1</sup>	D2	E	2E	2F	G	H	J	O	N	XM	LS	HS	HT	TL	TW
33 (A)	S2	8.50	6.61	5.51	5.24	1.18	4.72	5.51	.85	.55	2.86	9.69	3.54	11.97	1.29	7.14	6.00	15.50	16.50
34	S2	10.13	7.87	7.09	5.90	1.57	5.91	6.50	1.07	.71	2.67	12.05	4.49	13.78	2.31	7.17	6.00	15.50	16.50
35	S2	11.92	8.66	8.35	6.89	2.17	7.09	7.09	1.18	.87	3.45	13.58	5.20	15.95	2.35	8.48	6.00	15.50	16.50

### Output Shaft

Gear Frame	Version	EA	EA2	MC <sup>5</sup>	Bushing Bores <sup>4</sup>	
					Min.	Max.
33	S2	4.82	4.23	1.75	1 5/16	1 7/16
33A	S2	5.76	5.18	1.88	1 7/16	1 15/16
34	S2	5.84	5.27	1.88	1 11/16	1 15/16
35	S2	6.17	5.620	1.88	2	2 7/16

### Input Shaft

Gear Frame	Version	RU	U1 <sup>3</sup>	UY1	V1	Key1
33 (A)	S2	3.17	.625	.70	1.25	3/16 Sq.
34	S2	4.75	1.125	1.24	2.25	1/4 Sq.
35	S2	5.03	1.125	1.24	2.25	1/4 Sq.

Motor Frame	33		34		35	
	Center Distance		Center Distance		Center Distance	
	Min.	Max.	Min.	Max.	Min.	Max.
56	12.28	18.25	12.31	18.28	-	-
B56	12.28	18.25	12.31	18.28	13.87	19.34
182T/184T	13.28	19.26	13.31	19.28	14.87	20.34
213T/215T	-	-	14.06	20.03	15.62	21.09
254T/256T	-	-	-	-	16.62	22.09

<sup>1</sup> Dimension "D" will never be exceeded, but may vary from values shown. When exact dimensions are required, shims up to .03" may be necessary.

<sup>2</sup> All rough casting dimensions may vary by .25" due to casting variations.

<sup>3</sup> Input shaft extension tolerances: +.0000"; -.0005" for shafts up to 1.5" diameter. Larger diameter "U1", +.000"; -.001".

<sup>4</sup> Refer to page B-133 by gear frame for listing of all inch and metric bushing bore sizes available.

<sup>5</sup> The MC dimension shows spacing required to install or remove the bushing from the reducer.

<sup>6</sup> Bushing and dust cap can be installed opposite of how they are shown above.

<sup>7</sup> Driven shaft entry can be from either side of the gear reducer housing. Refer to installation manual for requirements.

<sup>8</sup> For details of the torque arm kit, refer to page B-129.

## 3-Stage Taper Bushed Shaft Mount OtN36 - 38

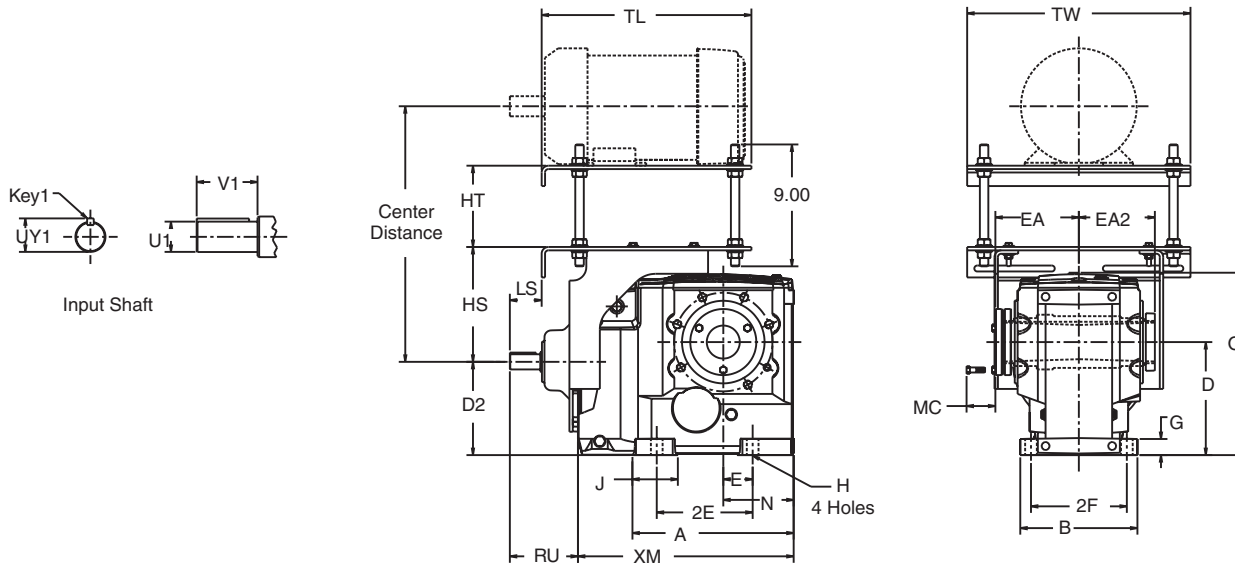

OtN Series

Gear Frame	Version	A	B	D <sup>1</sup>	D <sub>2</sub>	E	2E	2F	G	H	J	O	N	XM
36	S2	17.06	11.41	8.86	8.86	6.99	13.98	9.45	1.57	.87	3.87	16.26	8.74	23.11
37	S2	20.58	12.99	9.84	10.98	8.27	16.54	10.63	1.93	.94	4.78	18.29	10.04	28.44
38	S2	17.85	13.99	14.76	11.87	4.53	13.78	10.63	1.98	1.26	4.06	24.11	8.86	24.02

### Output Shaft

Gear Frame	Version	EA	EA <sub>2</sub>	MC <sup>5</sup>	Bushing Bores <sup>4</sup>	
					Min.	Max.
36	S2	6.81	7.83	1.88	2 7/16	2 15/16
37	S2	9.50	8.86	2.25	2 7/8	3 7/16
38	S2	8.66	8.08	2.75	2 15/16	3 15/16

### Input Shaft

Gear Frame	Version	RU	U <sub>1</sub> <sup>3</sup>	UY <sub>1</sub>	V <sub>1</sub>	Key <sub>1</sub>
36	S2	7.56	1.875	2.101	3.75	1/2 Sq.
37	S2	7.56	1.875	2.101	3.75	1/2 Sq.
38	S2	7.56	1.875	2.101	3.75	1/2 Sq.

### Top Mount

Gear Frame	LS	HS	HT		TL	TW
			Min.	Max.		
36	3.76	10.48	1.89	7.36	20.25	24.00
37	3.76	10.48	1.89	7.36	20.25	24.00
38	4.71	19.38	1.89	7.36	19.38	24.00

Motor Frame	36		37		38	
	Center Distance		Center Distance		Center Distance	
	Min.	Max.	Min.	Max.	Min.	Max.
182T/184T	16.73	22.73	16.73	22.73	25.78	31.25
213T/215T	17.48	23.48	17.48	23.48	26.53	32.00
254T/256T	18.48	24.48	18.48	24.48	27.53	33.00
284T/286T	19.23	25.23	19.23	25.23	28.28	33.75
324T/326T	20.23	26.23	20.23	26.23	29.28	34.75

<sup>1</sup> Dimension "D" will never be exceeded, but may vary from values shown. When exact dimensions are required, shims up to .03" may be necessary.

<sup>2</sup> All rough casting dimensions may vary by .25" due to casting variations.

<sup>3</sup> Input shaft extension tolerances: +.0000"; -.0005" for shafts up to 1.5" diameter. Larger diameter "U<sub>1</sub>", +.000"; -.001".

<sup>4</sup> Refer to page B-133 by gear frame for listing of all inch and metric bushing bore sizes available.

<sup>5</sup> The MC dimension shows spacing required to install or remove the bushing from the reducer.

<sup>6</sup> Bushing and dust cap can be installed opposite of how they are shown above.

<sup>7</sup> Driven shaft entry can be from either side of the gear reducer housing. Refer to installation manual for requirements.

<sup>8</sup> For details of the torque arm kit, refer to page B-129.

## 2-Stage CEMA Screw Conveyor Drive OtN32

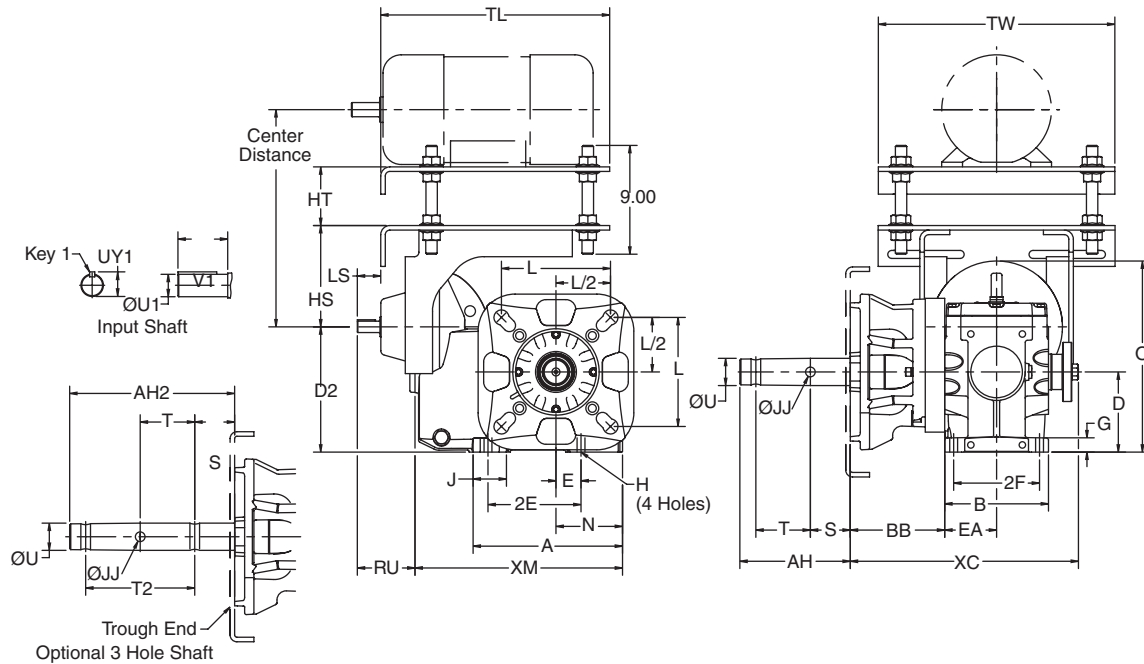

OtN Series

Gear Frame	Version	A	B	D'	D2	E	2E	2F	G	H	J	O	N	EA	XC	XM	LS	HS	HT	TL	TW
3242	S2	8.22	5.71	4.41	6.89	1.38	5.12	4.72	.79	.43	1.83	10.51	3.66	2.85	7.35	12.36	1.29	7.14	6.00	15.5	16.5

### Output Shaft

Gear Frame	Screw Dia.	JJ	L	U	S	T	T2	AH	AH2	BB
3242	6-10	.53	4.00	1.50	2.13	3.00	6.00	6.00	9.00	5.13
	9-12	.66	5.13	2.00	2.13	3.00	6.00	6.00	9.00	5.13
	12-14	.66	5.63	2.44	2.75	3.00	6.00	6.00	9.69	5.13
	12-20	.78	6.00	3.00	2.88	3.00	6.00	6.88	9.88	5.13

### Input Shaft

Gear Frame	Version	RU	U1 <sup>5</sup>	UY1	V1	Key1
3242	S2	3.17	.625	.705	1.25	3/16 Sq.

Motor Frame	Center Distance	
	Min.	Max.
56	12.28	18.25
B56	12.28	18.25
182T/184T	13.28	19.25

<sup>1</sup> Dimension "D" will never be exceeded, but may vary from values shown. When exact dimensions are required, shims up to .03" may be necessary.

<sup>2</sup> All rough casting dimensions may vary by .25" due to casting variations.

<sup>3</sup> Refer to pages B-131 and B-132 for the screw conveyor drive shafts, trough ends and other accessories available for each gear frame size.

<sup>4</sup> Thrust ratings for each gear frame size are listed on page B-131.

<sup>5</sup> Input shaft extension tolerances: +.0000"/-.0005" up to 1.5" diameter; larger diameters +.000"/-.001".

## 3-Stage CEMA Screw Conveyor Drive OtN33 - 35

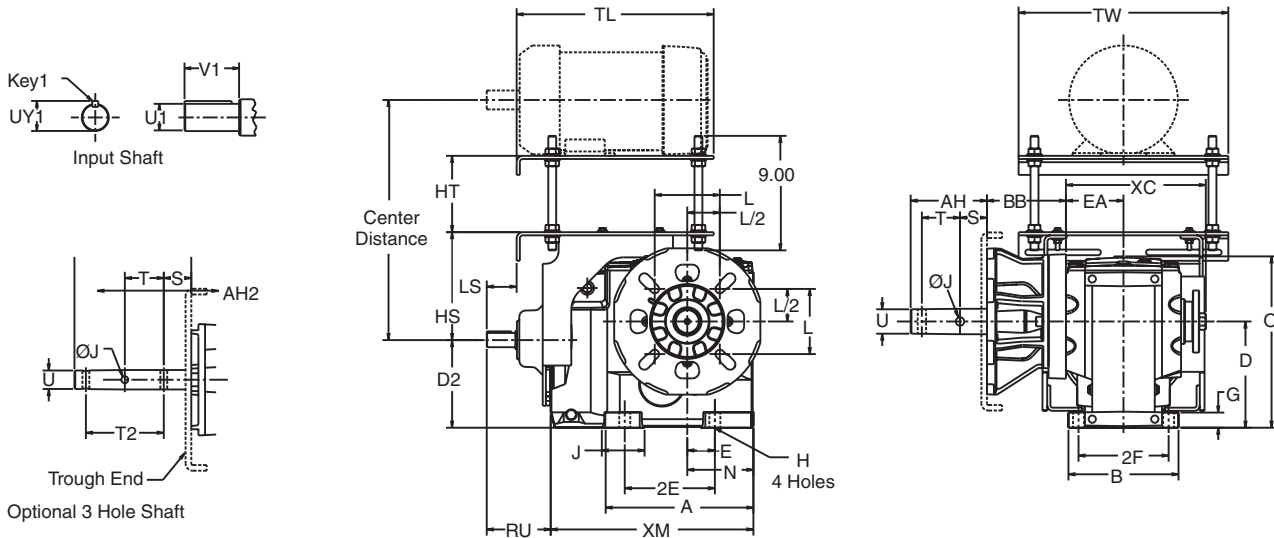

Gear Frame	Version	A	B	D <sup>1</sup>	D <sub>2</sub>	E	2E	2F	G	H	J	O	N	EA	XC	XM	LS	HS	HT	TL	TW
33	S2	8.50	6.61	5.51	5.24	1.18	4.72	5.51	.85	.55	2.86	9.69	3.54	3.35	8.30	11.97	1.29	7.14	6.00	15.50	16.50
34	S2	10.13	7.87	7.09	5.90	1.57	5.91	6.50	1.07	.71	2.67	12.05	4.49	4.07	9.84	13.78	2.31	7.17	6.00	15.50	16.50
35	S2	11.92	8.66	8.35	6.89	2.17	7.09	7.09	1.18	.87	3.37	13.58	5.20	4.43	11.00	15.95	2.35	8.48	6.00	15.50	16.50

### Screw Conveyor

Gear Frame	Screw Dia.	J	L	U	S	T	T <sub>2</sub>	AH	AH <sub>2</sub>	BB
32, 33	6 - 10	.53	4.00	1.50	2.13	3.00	6.00	6.00	9.00	5.13
	9 - 12	.66	5.13	2.00	2.13	3.00	6.00	6.00	9.00	5.13
	12 - 14	.66	5.63	2.44	2.75	3.00	6.00	6.00	9.69	5.13
	12 - 20	.78	6.00	3.00	2.88	3.00	6.00	6.88	9.88	5.13
34	6 - 10	.53	4.00	1.50	2.13	3.00	6.00	6.00	9.00	5.13
	9 - 12	.66	5.13	2.00	2.13	3.00	6.00	6.00	9.00	5.13
	12 - 14	.66	5.63	2.44	2.75	3.00	6.00	6.00	9.69	5.13
	12 - 20	.78	6.00	3.00	2.88	3.00	6.00	6.88	9.88	5.13
35	9 - 12	.66	5.13	2.00	2.13	3.00	6.00	6.00	9.00	6.21
	12 - 14	.66	5.63	2.44	2.75	3.00	6.00	6.69	9.69	6.21
	12 - 20	.78	6.00	3.00	2.88	3.00	6.00	6.88	9.88	6.21
	18 - 24	.91	6.75	3.44	3.88	4.00	-	9.13	-	6.21

### Input Shaft

Gear Frame	Version	RU	U <sup>1</sup>	UY <sub>1</sub>	V <sub>1</sub>	Key <sub>1</sub>
33	S2	3.17	.625	.70	1.25	3/16 Sq.
34	S2	4.75	1.125	1.24	2.25	1/4 Sq.
35	S2	5.03	1.125	1.24	2.25	1/4 Sq.

Motor Frame	33		34		35	
	Center Distance		Center Distance		Center Distance	
	Min.	Max.	Min.	Max.	Min.	Max.
56	12.28	18.25	12.31	18.28	-	-
143T/145T	12.28	18.25	12.31	18.28	13.87	19.34
182T/184T	13.28	19.26	13.31	19.28	14.87	20.34
213T/215T	-	-	14.06	20.03	15.62	21.09
254T/256T	-	-	-	-	16.62	22.09

<sup>1</sup> Dimension "D" will never be exceeded, but may vary from values shown. When exact dimensions are required, shims up to .03" may be necessary.

<sup>2</sup> All rough casting dimensions may vary by .25" due to casting variations.

<sup>3</sup> Refer to pages B-131 and B-132 for the screw conveyor drive shafts,

trough ends and other accessories available for each gear frame size.

<sup>4</sup> Thrust ratings for each gear frame size are listed on page B-131.

<sup>5</sup> Input shaft extension tolerances: +.0000"/-.0005" up to 1.5" diameter; larger diameters +.000"/-.001".

## 3-Stage CEMA Screw Conveyor Drive OtN36-37

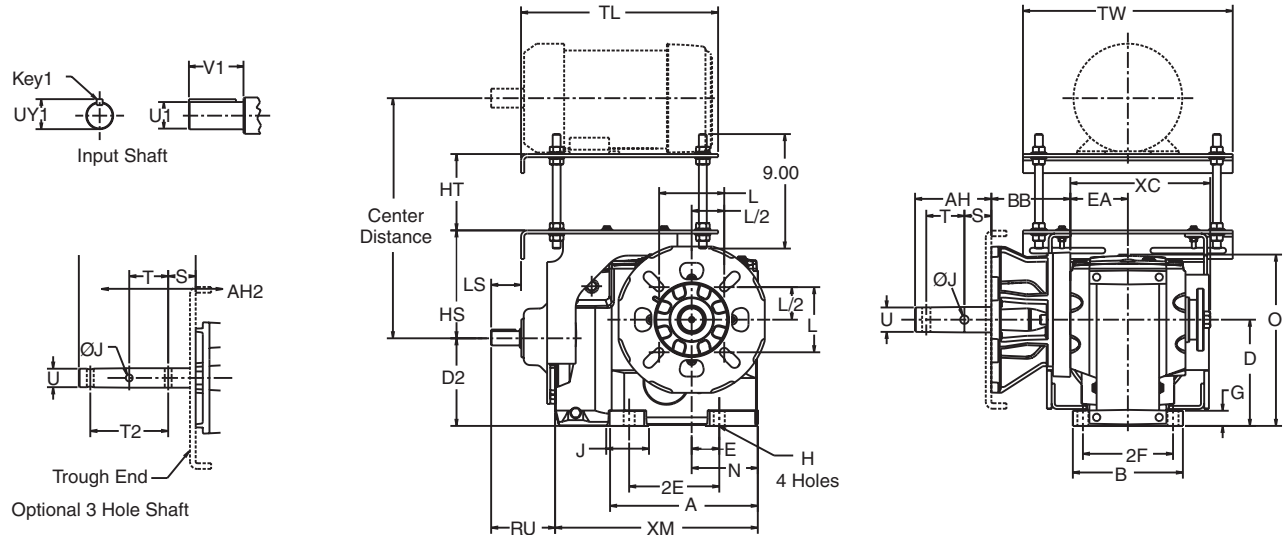

# OtN Series

Gear Frame	Version	A	B	D <sup>1</sup>	D2	E	2E	2F	G	H	J	O	N	EA	XC	XM
36	S2	17.06	11.41	8.86	8.86	6.99	13.98	9.45	1.57	.87	3.87	16.26	8.74	6.02	13.14	23.11
37	S2	20.58	12.99	9.84	10.98	8.27	16.54	10.63	1.93	.94	4.78	18.29	10.04	6.61	14.76	28.44

### Screw Conveyor

Gear Frame	Screw Dia.	JJ	L	U	S	T	T2	AH	AH2	BB
36	9-12	.66	5.13	2.00	2.13	3.00	6.00	6.00	9.00	6.67
	12, 14	.66	5.63	2.44	2.75	3.00	6.00	6.69	9.69	6.67
	12-20	.78	6.00	3.00	2.88	3.00	6.00	6.88	9.88	6.67
	18-24	.91	6.75	3.44	3.88	4.00	8.00	9.13	13.13	6.67
37	12-20	.78	6.00	3.00	2.88	3.00	6.00	6.88	9.88	7.94
	18-24	.91	6.75	3.44	3.88	4.00	8.00	9.13	13.13	7.94

### Input Shaft

Gear Frame	Version	RU	U1 <sup>5</sup>	UY1	V1	Key1
36	S2	7.56	1.875	2.101	3.75	1/2 Sq.
37	S2	7.56	1.875	2.101	3.75	1/2 Sq.

### Top Mount

Gear Frame	LS	HS	HT		TL	TW
			Min.	Max.		
36	3.76	10.48	1.89	7.36	20.25	24.00
37	3.76	10.48	1.89	7.36	20.25	24.00

Motor Frame	36		37	
	Center Distance		Center Distance	
	Min.	Max.	Min.	Max.
182T/184T	16.73	22.73	16.73	22.73
213T/215T	17.48	23.48	17.48	23.48
254T/256T	18.48	24.48	18.48	24.48
284T/286T	19.23	25.23	19.23	25.23
324T/326T	20.23	26.23	20.23	26.23

<sup>1</sup> Dimension "D" will never be exceeded, but may vary from values shown. When exact dimensions are required, shims up to .03" may be necessary.

<sup>2</sup> All rough casting dimensions may vary by .25" due to casting variations.

<sup>3</sup> Refer to pages B-131 and B-132 for the screw conveyor drive shafts, trough ends and other accessories available for each gear frame size.

<sup>4</sup> Thrust ratings for each gear frame size are listed on page B-131.

<sup>5</sup> Input shaft extension tolerance (U1): +.0000"/-.0005" up to 1.5" diameter; larger diameters +.000"; -.001".



### C-Face Reducers

Gear Frame	Reduction Stages	Input Size							
		56C	140TC	180TC	210TC	250TC	280TC	320TC	360TC
31	2	44	44	-	-	-	-	-	-
32	2	49	49	55	-	-	-	-	-
	3	56	56	62	-	-	-	-	-
	5	64	64	-	-	-	-	-	-
33 (A)	3	68	68	77	77	-	-	-	-
	5,6	98	98	-	-	-	-	-	-
34	3	118	118	127	127	-	-	-	-
	5,6	147	147	-	-	-	-	-	-
35	3	190	190	199	199	204	206	-	-
	5,6	210	210	219	-	-	-	-	-
36	3	-	351	360	360	365	367	-	-
	5,6	401	401	419	419	-	-	-	-
37	3	-	-	540	540	545	547	575	575
	5,6	576	576	585	585	-	-	-	-
38	3	-	-	-	850	855	857	885	-
	5,6	860	860	869	869	-	-	-	-

### Input Shaft Reducers

Gear Frame	Reduction Stages	Style		
		AP/AD	Scoop	Top Mt.
31	2	40	-	-
32	2	45	-	100
	3	52	-	-
	5	60	-	-
33 (A)	3	74	99	121
	5,6	104	-	-
34	3	123	156	170
	5,6	151	-	-
35	3	195	247	266
	5,6	215	-	-
36	3	363	405	RO
	5,6	415	448	462
37	3	558	578	RO
	5,6	602	635	649
38	3	770	863	RO
	5,6	789	841	859

### Gear Options

Gear Frame	Std Flange Mount	Footed S1	37S or 73S SCD
31	3	-	-
32	4	-	35
33	5	2	35
34	7	3	42
35	8	5	75
36	10	-	109
37	12	-	130
38	15	-	-

## Lubrication

Series 3000 OtN gearing are shipped with one of the following synthetic lubricants per the table below and fitted with a magnetic drain. Each reducer is filled according to the mounting position specified when ordered. Refer to unit nameplate and the chart on page B-16 or B-121 for mounting position arrangement for your unit.

In the case of synthetic oil, the lubricant does not require changing but it is recommended that proper oil level be checked periodically.

### Standard Synthetic Gear Oil (Non-Food Grade)

No Backstop		With Backstop (1)	
Manufacturer	-25° F to 125° F (-30° C to 50° C)	Manufacturer	-25° F to 125° F (-30° C to 50° C)
Fuchs*	Sintogear* 125	Shell*	Omala* RL 100
Mobil*	Mobilgear* SHC 150	Mobil*	SHC 629
Shell*	Omala* Fluids HD 150		

### Standard Synthetic Gear Oil (H1 Rated Food Grade Requirements)

No Backstop	
Manufacturer	22° F to 125° F (-20° C to 50° C)
Mobil*	SHC Cibus 150

### CAUTION

- Never mix synthetic oil and mineral oil.
- Never use extreme pressure (EP) oil in a reducer with a backstop.
- Refer to installation and maintenance manual for mineral oil selection.

### Foot Mounted Triple Reduction Designs - US Quarts (Litre = Quart x .946)

Gear Frame Size	Mounting Config.	Mounting Position					
		B	P	H	T	V	W
3132	S2	0.95	1.06	0.95	0.80	1.64	1.11
3242	S2	1.96	2.06	1.74	2.06	3.12	2.48
3243	S1, S2	0.55	1.82	1.50	1.50	2.00	1.40
3363	S2	1.16	3.70	3.49	2.96	3.96	2.75
	S1	3.70	1.16	2.96	3.49	3.96	2.75
3473	S2	1.37	6.45	5.39	4.65	6.76	3.91
	S1	6.45	1.37	4.65	5.39	6.76	3.91
3583	S2	2.85	8.88	5.39	7.72	11.42	6.61
	S1	8.88	2.65	7.72	5.39	11.42	6.61
3693	S1, S2	6.08	19.24	14.28	12.90	23.36	13.95
3703	S1, S2	10.58	25.00	20.30	17/97	35.94	25.05
3823	S2	10.57	34.87	29.06	22.19	43.32	25.36

### Face, Flange<sup>1</sup> or Shaft Mounted Triple Reduction Designs - US Quarts (Litre = Quart x .946)

Gear Frame Size	Mounting Config.	Mounting Position					
		B	P	H	T	V	W
3132	S2	0.95	1.06	0.95	0.80	1.64	1.11
3242	S2	1.96	2.06	1.74	2.06	3.12	2.48
3243	S2, S1	0.55	1.82	1.50	1.50	2.00	1.40
3363	S2, S1	1.16	3.70	3.49	2.96	3.96	2.75
3363A	S2	1.16	3.70	3.49	2.96	3.96	2.75
3473	S2, S1	1.37	6.45	5.39	4.65	6.76	3.91
3583	S2, S1	2.85	8.88	5.39	7.72	11.42	6.61
3693	S2	6.08	19.24	14.28	12.90	23.36	13.95
3703	S2	10.58	25.00	20.30	17/97	35.94	25.05
3823	S2	10.57	34.87	29.06	22.19	43.32	25.36

<sup>1</sup> This table defines oil volumes for types "5", "6" and "7" flanged gearing.

\*The following are believed to be the trademarks and/or trade names of their respective owners and are not owned or controlled by Emerson Power Transmission. Fuchs and Sintogear: Fuchs Petrolube AG; Mobil and Mobilgear: Exxon Mobil Corporation; Shell and Omala: Shell Oil Company.